

# K451B

v.01

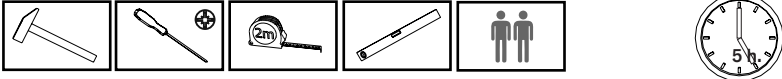

<b>A x 03</b> 	<b>B x 03</b> 	<b>E x 23</b> 	<b>F x 23</b> 	<b>G x 44</b>  3.5 x 15 mm.	<b>H x 17</b>  4 x 16 mm.
<b>J x 04</b>  4 x 30 mm.	<b>K x 30</b>  M4 x 10 mm.	<b>L x 30</b>  M4 x 15 mm.	<b>M x 03</b>  M4 x 15 mm.	<b>N x 48</b>  5 x 60 mm.	<b>Ñ x 10</b>  M6 x 60 mm.
<b>O x 04</b>  13 mm.	<b>P x 06</b>  21 mm.	<b>R x 30</b> 	<b>T x 01</b> 	<b>U x 26</b> 	<b>V x 02</b> 
<b>W x 02</b> 	<b>Y x 06</b> 	<b>Z x 06</b> 	<b>AA x 02</b> 	<b>AB x 22</b> 	<b>AC x 08</b> 
<b>AD x 01</b>  N° 3	<b>AE x 01</b>  N° 4	<b>AF x 03</b>  M4 x 30 mm.	<b>AI x 08</b> 	<b>AJ x 08</b>  3.5 x 20 mm.	<b>AK x 35</b>  4 x 20 mm.
<b>C x 39</b> 	<b>D x 12</b>  10 x 70 mm.	<b>S x 03</b> 	<b>AG x 79</b>  17 mm.	<b>AH x 02</b>  7 mm.	

## ES

### RECOMENDACIONES MONTAJE Y USO

Agrupe y cuente el herraje.  
Prepare todas las piezas para el montaje del mueble.  
Tenga preparadas las herramientas para el montaje.  
Prepare la zona del montaje.  
Monte el mueble sobre una moqueta para evitar rayar y dañar la superficie del mueble.  
No fuerce los ensamblajes.  
Evite colocar el mueble cerca de fuentes de calor.  
Evite utilizar trapos, paños o productos de limpieza que puedan dañar la superficie del mueble.  
Mueble para uso doméstico en interior de vivienda.

## FR

### CONSEILS DE MONTAGE CONSEILS POUR L'USAGE

Préparez les différents parts du meuble  
Regrouper et compter toute la quincaillerie  
Préparez l'outillage nécessaire  
Aménagez-vous une area de montage  
Faire le montage sur moquette afin de protéger le meuble des rayures  
Ne forcer pas le montage  
Évitez placer le meuble près des sources de chaleur  
Évitez utiliser de chiffons ou des produits de nettoyage pour ne pas rayer la superficie du meuble  
Meuble d'usage domestique pour l'intérieur de la maison.

## PT

### RECOMENDAÇÕES PARA MONTAGEM E USO

Prepare todas as peças para a montagem de móveis  
Reagrupar e contar o hardware  
Preparar as ferramentas de montagem  
Preparar a área de montagem  
Montar as peças sem tapete para evitar riscos e danos na superfície dos móveis  
Não force as assembleias  
Não colocar móveis perto de fontes de calor  
Evitar o uso de panos, trapos ou produtos de limpeza que possam riscar o móvel.  
Móveis para uso doméstico no interior da casa.

## NL

### AANBEVELINGEN VOOR MONTAGE EN GEBRUIK

Bereid alle onderdelen van het meubilair voor  
Groeperen en tellen van alle hardware  
Bereid al het gereedschap voor op de montage.  
Maak de montageplaats vrij en bereid deze voor.  
Doe de montage op een tapijt om te voorkomen dat het oppervlak van het meubilair wordt beschadigd.  
Vermijd het forceren van de fittingen  
Vermijd het plaatsen van het meubilair in de buurt van een verwarmingsbron.  
Gebruik geen doeken of reinigingsmiddelen om te voorkomen dat het oppervlak van het meubilair wordt beschadigd.  
Binnenmeubilair. Geschikt voor huishoudelijk gebruik.

## EN

### RECOMMENDATIONS FOR ASSEMBLY AND USE

Prepare all the parts of the furniture  
Group and count all the hardware  
Prepare all the tools for the assembly.  
Clear and prepare the assembly area.  
Do the assembly on a carpet to avoid damaging the surface of the furniture  
Avoid forcing the fittings  
Avoid placing the Furniture near any heating source  
Do not use cloths or cleaning products to avoid damaging the surface of the furniture  
Indoor furniture. Suitable for domestic use.

## DE

### MONTAGEHINWEISE- GEBRAUCHSHINWEISE

Identifizieren Sie die Einzelteile  
Überprüfen Sie Die Anzahl der einzelnen Beschlagteile  
Legen Sie das notwendige Werkzeug bereit  
Bereiten die Montagefläche  
Montieren Sie das Möbel auf einem Teppich, säubern Untergrund  
Niemals die verbindungen zu start anziehen  
Nicht neben Wärmequellen platzieren  
Vermeiden Sie Tücher und keinesfalls scharfe oder ätzende Reinigungsmittel.  
Möbel für den Gebrauch im Haus geeignet.

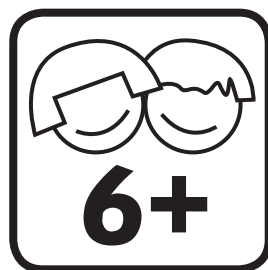

Las camas altas y la cama superior de las literas, no son adecuadas para niños menores de seis años, debido al riesgo de lesiones por caídas.

High beds and top bunk beds are not suitable for children under six years of age, due to the risk of injury from falls



**Option A**

**Option B**

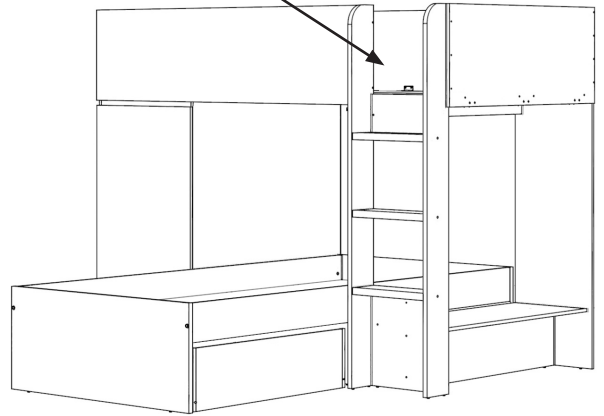
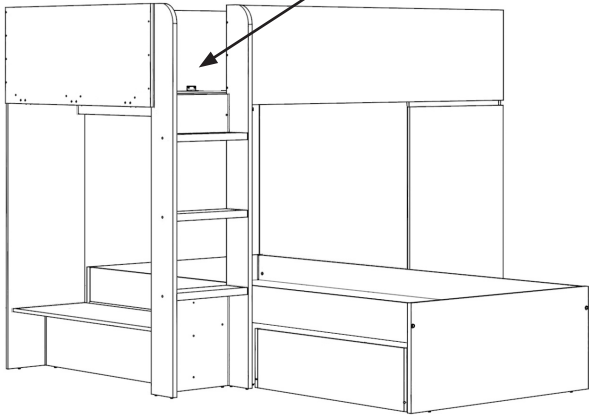

**PAG. 7-33**



**MATTRESS: 90x190 cm. H Max. 19 cm.**



**Option C**

**Option D**

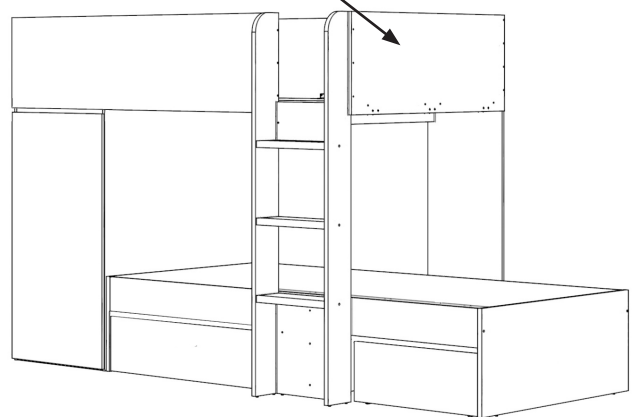
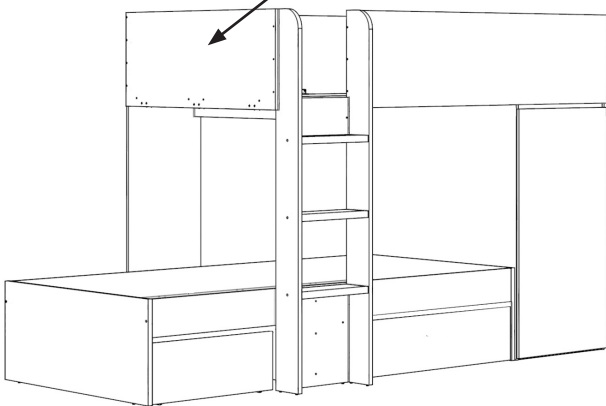

**PAG. 34-61**

## ES

### **IMPORTANTE. LEA LAS INSTRUCCIONES DETENIDAMENTE Y CONSÉRVELAS PARA CONSULTAS POSTERIORES.**

#### **ADVERTENCIAS:**

1. Las camas altas y la cama superior de las literas, no son adecuadas para niños menores de seis años, debido al riesgo de lesiones por caídas.
2. Las literas y las camas altas pueden presentar un riesgo grave de estrangulamiento, si no se utilizan correctamente. No se debe sujetar o colgar en ninguna parte de la litera, ningún elemento que no esté diseñado para utilizarlo con la cama. Por ejemplo (pero pueden haber otros): cuerdas, cordeles, cordones, ganchos, correas y bolsas.
3. Los niños pueden quedar atrapados entre la cama y la pared, el techo, el tejado, otros elementos de muebles adyacentes (por ejemplo, armarios) y similares. Para evitar el riesgo de lesiones graves, la distancia entre la barrera de seguridad superior y la estructura adyacente, no debe ser superior a 75 mm, o debe ser mayor de 230 mm.
4. No utilizar la litera o la cama alta si alguno de sus componentes estructurales está roto o falta.

#### **INFORMACIÓN:**

- Seguir siempre las instrucciones del fabricante.
- El espesor máximo del colchón debe ser **19 cm**.
- Tamaño de colchón debe ser **90x190 cm**.

#### **INDICACIONES:**

- La habitación debe estar ventilada para mantener una humedad baja e impedir la formación de moho en la cama y sus alrededores.
- Revisar periódicamente que todos los elementos de fijación estén correctamente ajustados.

**Este mueble cumple con los requisitos de la Norma EN 747-1:2012+A1:2015**

## FR

### **IMPORTANT. LISEZ ATTENTIVEMENT LES INSTRUCTIONS ET CONSERVEZ-LES POUR VOUS Y RÉFÉRER**

#### **ULTÉRIEUREMENT.**

#### **AVERTISSEMENTS :**

1. Les lits hauts et les lits superposés supérieurs ne conviennent pas aux enfants de moins de six ans, en raison du risque de blessures dues à des chutes.
2. Les lits hauts et les lits superposés peuvent présenter un risque sérieux de strangulation s'ils ne sont pas utilisés correctement. Rien ne doit être attaché ou accroché sur la couchette qui n'est pas conçu pour être utilisé avec le lit. Par exemple (mais il peut y en avoir d'autres) : cordes, ficelles, cordages, crochets, sangles et sacs.
3. Les enfants peuvent être coincés entre le lit et le mur, le plafond, le toit, d'autres meubles adjacents (par exemple les placards) et autres. Pour éviter le risque de blessure grave, la distance entre la barrière de sécurité supérieure et la structure adjacente ne doit pas dépasser 75 mm, ou doit être supérieure à 230 mm.
4. N'utilisez pas la couchette ou le lit haut si l'un de ses éléments structurels est cassé ou manquant.

#### **INFORMATION :**

- Suivez toujours les instructions du fabricant.
- L'épaisseur maximale du matelas doit être de **19 cm**.
- La taille du matelas doit être de **90x190 cm**.

#### **INDICATIONS :**

- La pièce doit être ventilée pour maintenir un faible taux d'humidité et empêcher la formation de moisissures dans et autour du lit.
- Vérifiez périodiquement que tous les éléments de fixation sont correctement réglés.

**Ce mobilier est conforme aux exigences de la norme EN 747-1:2012+A1:2015**

## EN

### **IMPORTANT. PLEASE READ THE INSTRUCTIONS CAREFULLY AND KEEP THEM FOR FUTURE REFERENCE.**

#### **WARNINGS :**

1. Loft beds and upper bunks are not suitable for children under the age of six, due to the risk of injury from falls.
2. Bunk beds and high beds can present a serious risk of strangulation if not used correctly. Any item not designed for use with the bed should not be placed or hung anywhere on the bunk bed. For example (but there may be others): ropes, laces, laces, hooks, straps, and bags.
3. Children can become trapped between the bed and the wall, the ceiling, the ceiling, other adjacent furniture elements (for example, cabinets) and the like. To avoid the risk of serious injury, the distance between the upper safety barrier and the adjacent structure must not exceed 75 mm and must not be more than 230 mm.
4. Do not use the bunk bed or high bed if any of its structural components is broken or missing.

#### **INFORMATION :**

- Always follow the manufacturer's instructions.
- The maximum thickness of the mattress must be **19 cm**.
- Mattress size must be **90x190 cm**.

#### **INDICATIONS :**

- The room should be ventilated to maintain low humidity and prevent mold growth in and around the bed.
- Periodically check that all fasteners are properly tightened.

**This furniture complies with the requirements of EN 747-1: 2012 + A1: 2015**

**PT****IMPORTANTE LEIA AS INSTRUÇÕES COM ATENÇÃO E MANTENHA-AS PARA FUTURA REFERÊNCIA.****ADVERTÊNCIAS:**

1. Camas altas e beliches superiores não são adequados para crianças menores de seis anos, devido ao risco de lesões por quedas.
2. Beliches e camas altas podem apresentar um sério risco de estrangulamento se não forem usadas corretamente. Qualquer item não projetado para uso com a cama não deve ser colocado ou pendurado em nenhum lugar do beliche. Por exemplo (mas pode haver outros): cordas, cordões, cordões, ganchos, correias e bolsas.
3. As crianças podem ficar presas entre a cama e a parede, o teto, o teto, outros elementos de móveis adjacentes (por exemplo, armários) e similares. Para evitar o risco de ferimentos graves, a distância entre a barreira de segurança superior e a estrutura adjacente não deve exceder 75 mm ou 230 mm.
4. Não use a cama de beliche ou a cama alta se algum de seus componentes estruturais estiver quebrado ou ausente.

**INFO:**

- Sempre siga as instruções do fabricante.
- A espessura máxima do colchão deve ser de **19 cm**.
- O tamanho do colchão deve ser de **90x190 cm**.

**INDICAÇÕES:**

- A sala deve ser ventilada para manter a umidade baixa e impedir o crescimento de fungos dentro e ao redor da cama.
- Periodicamente, verifique se todos os parafusos estão bem apertados.

**Este móvel está em conformidade com os requisitos da EN 747-1: 2012 + A1: 2015**

**NL****BELANGRIJK LEES DE INSTRUCTIES ZORGVULDIG EN BEWAAR VOOR TOEKOMSTIGE REFERENTIE.****WAARSCHUWINGEN:**

1. Hoogslapers en stapelbedden zijn niet geschikt voor kinderen onder de zes jaar vanwege het risico op verwondingen door vallen.
2. Stapelbedden en hoogslapers kunnen bij misbruik een ernstig risico op verwurging opleveren. Elk item dat niet is ontworpen voor gebruik met het bed mag niet worden bevestigd aan of opgehangen aan enig deel van het stapelbed. Bijvoorbeeld (maar er kunnen er meer zijn): touwen, veters, veters, haken, riemen en tassen.
3. Kinderen kunnen bekneld raken tussen het bed en de muur, het plafond, het plafond, andere aangrenzende meubelelementen (bijvoorbeeld kasten) en dergelijke. Om het risico op ernstig letsel te voorkomen, mag de afstand tussen de bovenste veiligheidsbarrière en de aangrenzende constructie niet groter zijn dan 75 mm of meer dan 230 mm.
4. Gebruik het stapelbed of het hoge stapelbed niet als een van de structurele componenten kapot is of ontbreekt.

**INFO:**

- Volg altijd de instructies van de fabrikant.
- De maximale dikte van de matras kan **19 cm** zijn.
- De afmeting van de matras moet **90x190 cm** zijn.

**INDICATIES:**

- De kamer moet worden geventileerd om een lage luchtvochtigheid te behouden en schimmelgroei in en rond het bed te voorkomen.
- Controleer regelmatig of alle bevestigingen goed zijn vastgedraaid.

**Dit meubilair voldoet aan de eisen van EN 747-1: 2012 + A1: 2015**

**DE****WICHTIG BITTE LESEN SIE DIE ANWEISUNGEN SORGFÄLTIG DURCH UND BEWAHREN SIE SIE FÜR ZUKÜNFTIGE REFERENZEN AUF.****WARNHINWEISE:**

1. Hochbetten und obere Kojen sind wegen des Verletzungsrisikos durch Stürze nicht für Kinder unter sechs Jahren geeignet.
2. Etagenbetten und Hochbetten können bei Missbrauch ein ernstes Strangulationsrisiko darstellen. Gegenstände, die nicht für die Verwendung mit dem Bett vorgesehen sind, dürfen nicht an der Koje befestigt oder an einer anderen Stelle der Koje aufgehängt werden. Zum Beispiel (aber es kann auch andere geben): Seile, Schnürsenkel, Schnürsenkel, Haken, Gurte und Taschen.
3. Kinder können zwischen dem Bett und der Wand, der Decke, der Decke, anderen angrenzenden Möbelementen (z. B. Schränken) und dergleichen eingeklemmt werden. Um das Risiko schwerer Verletzungen zu vermeiden, darf der Abstand zwischen der oberen Sicherheitsbarriere und der angrenzenden Struktur 75 mm und 230 mm nicht überschreiten.
4. Verwenden Sie das Etagenbett oder Hochbett nicht, wenn eines der Bauteile beschädigt ist oder fehlt.

**INFO:**

- Befolgen Sie immer die Anweisungen des Herstellers.
- Die maximale Dicke der Matratze muss **19 cm** betragen.
- Die Matratzengröße muss **90x190 cm** betragen.

**INDIKATIONEN:**

- Der Raum sollte belüftet werden, um die Luftfeuchtigkeit niedrig zu halten und zu verhindern, dass sich Schimmel im und um das Bett bildet.
- Überprüfen Sie regelmäßig, ob alle Befestigungselemente ordnungsgemäß konfiguriert sind.

**Dieses Möbel entspricht den Anforderungen der EN 747-1: 2012 + A1: 2015**

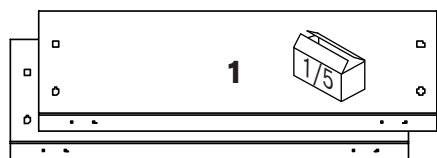

818 x 214 mm.

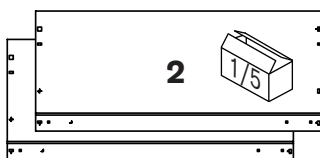

590 x 215 mm.

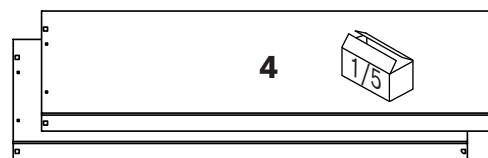

934 x 215 mm.

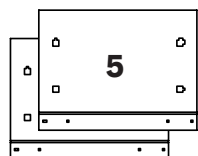

324 x 214 mm.



917 x 340 mm.

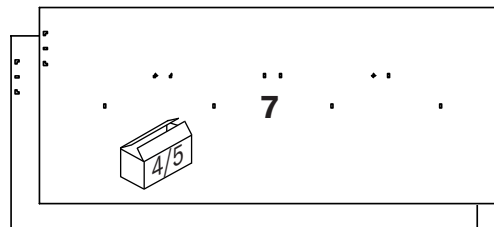

958 x 401 mm.

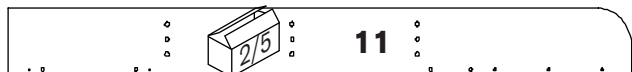

1494 x 138 mm.



1930 x 148 mm.

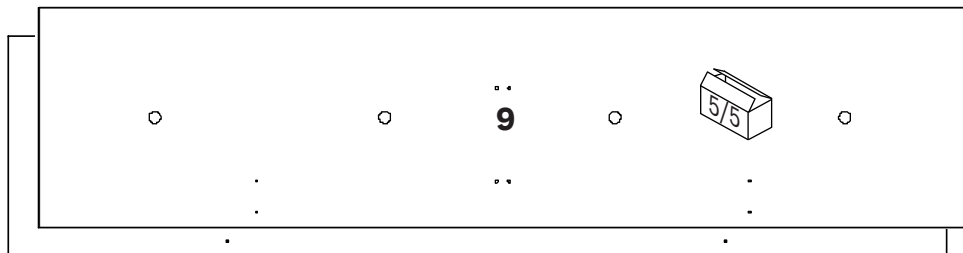

1928 x 455 mm.

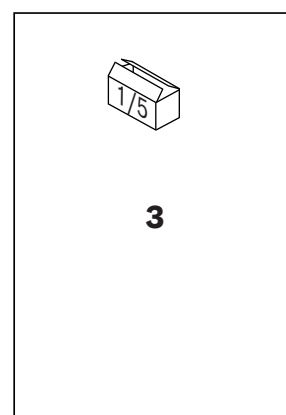

834 x 573 mm.

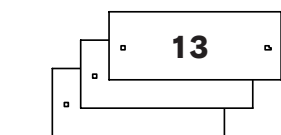

350 x 136 mm.

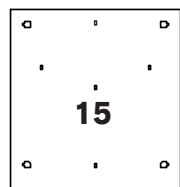

350 x 365 mm.

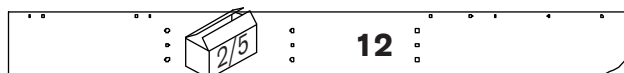

1494 x 138 mm.

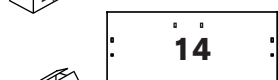

350 x 150 mm.

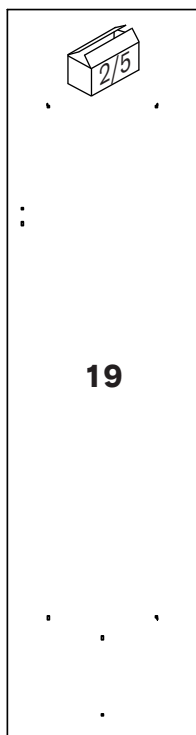

394 x 1494 mm.



910 x 274 mm.



959 x 235 mm.

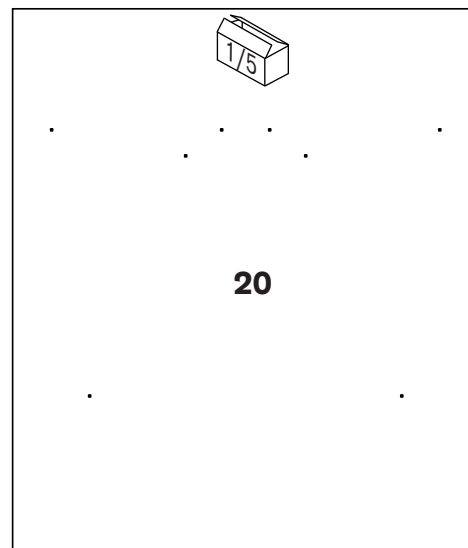

958 x 1124 mm.

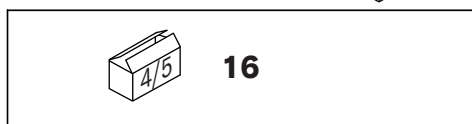

959 x 369 mm.

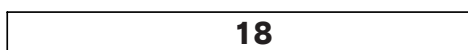

958 x 90 mm.



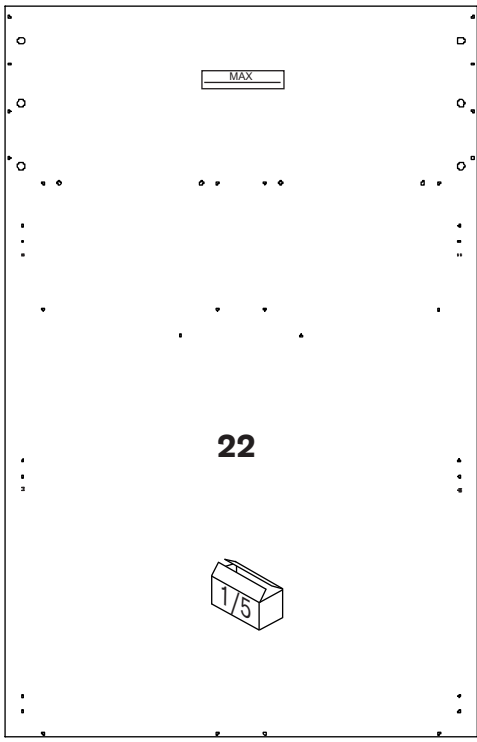

958 x 1494 mm.

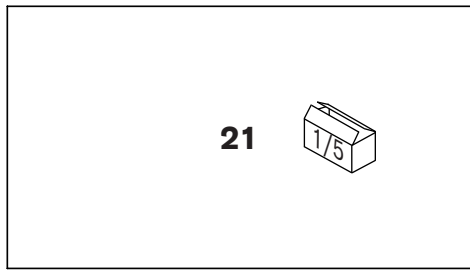

956 x 538 mm.

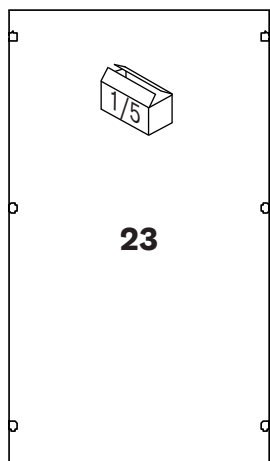

538 x 930 mm.

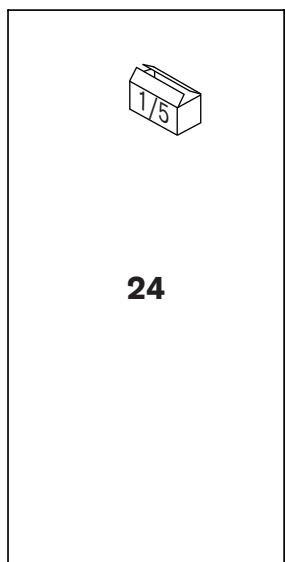

568 x 1089 mm.

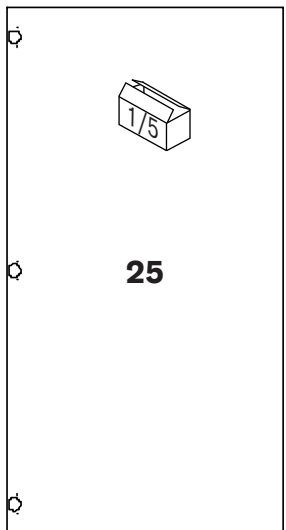

568 x 1044 mm.

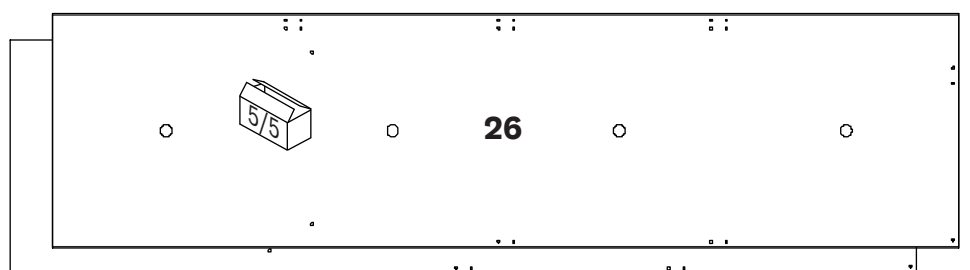

1910 x 479 mm.

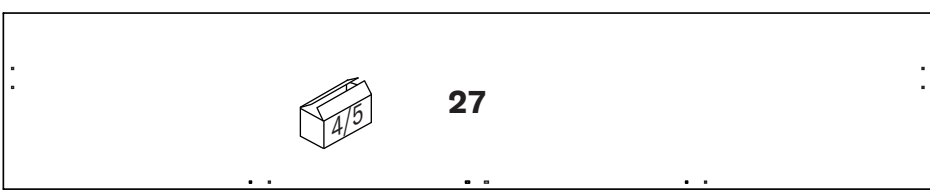

1910 x 353 mm.

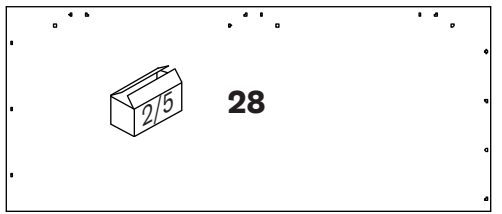

978 x 400 mm.

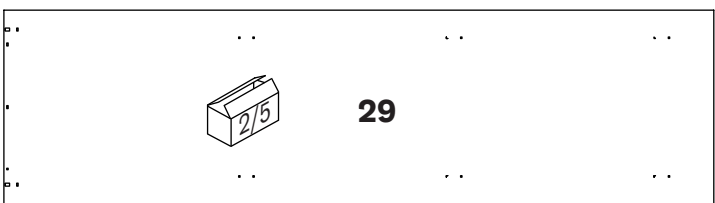

1533 x 398 mm.

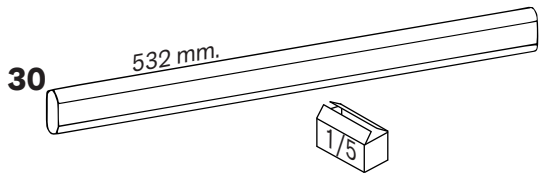

532 mm.

# Option A, B

PAG. 7-34

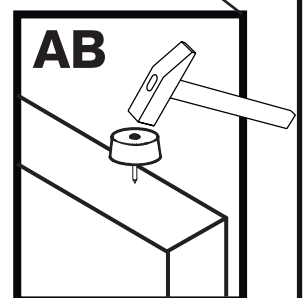
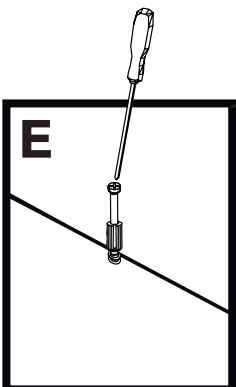
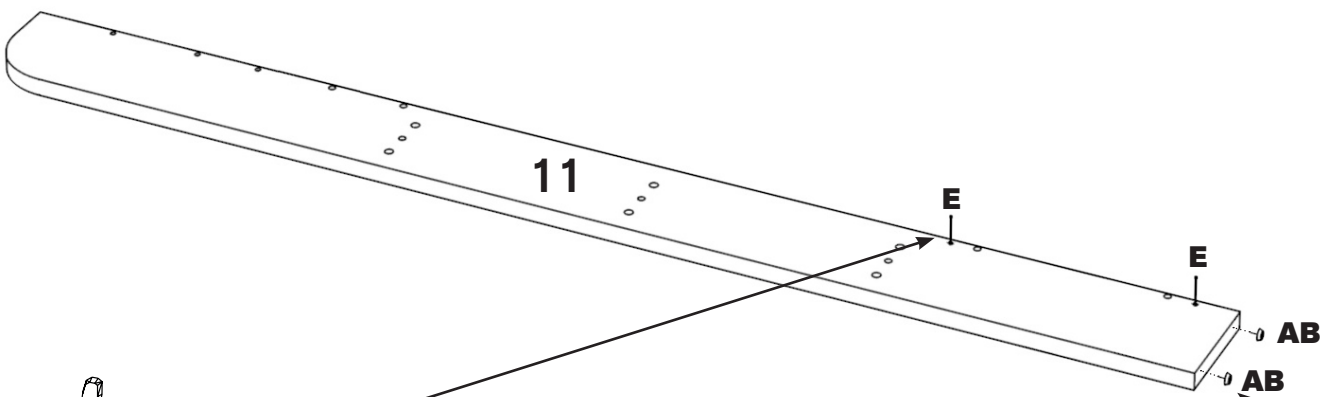
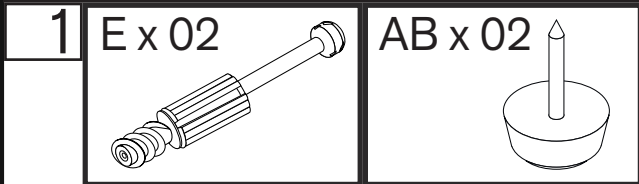
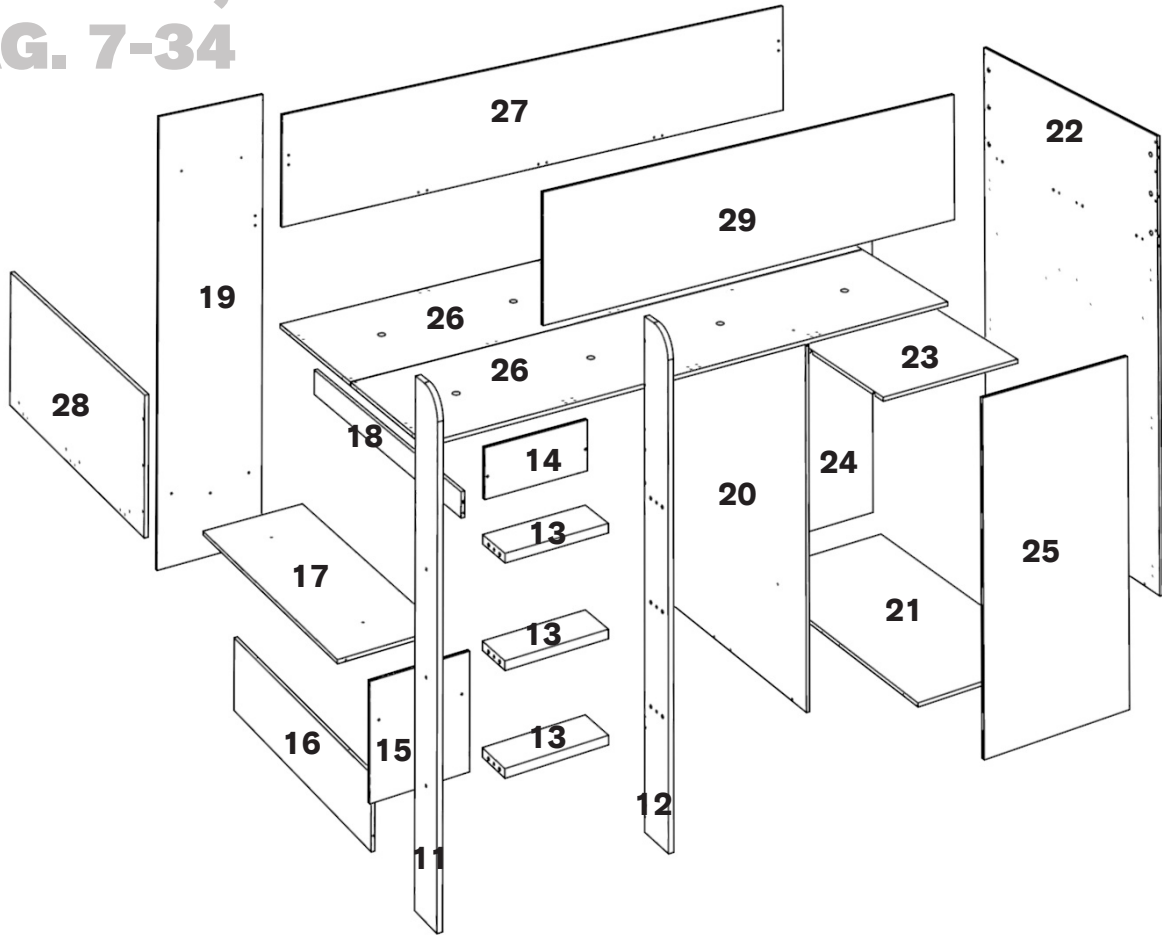

2 E x 02

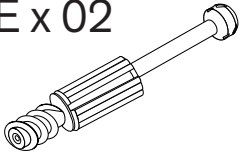

AB x 02

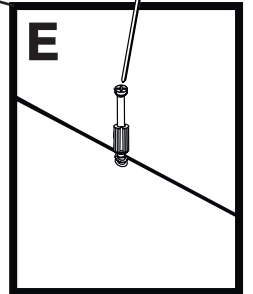
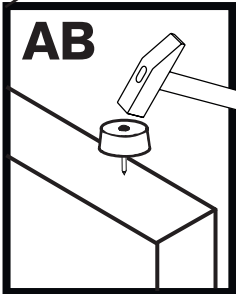
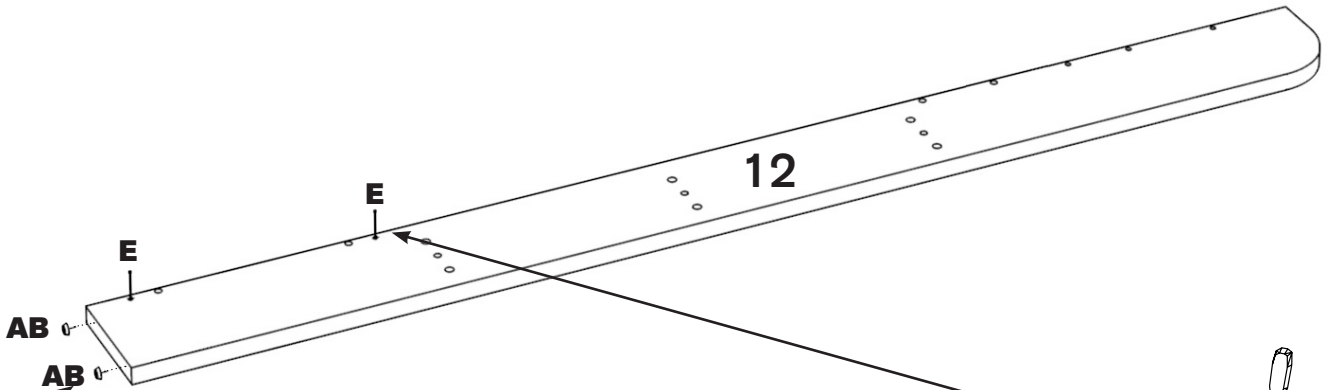
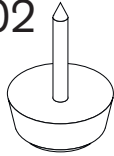

3 D x 12

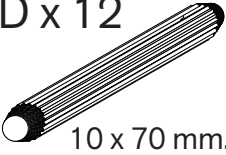

P x 06

21 mm.

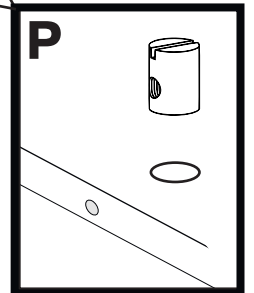
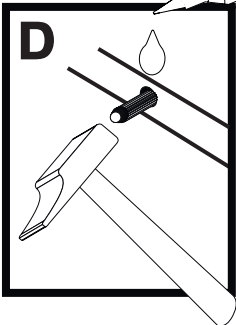
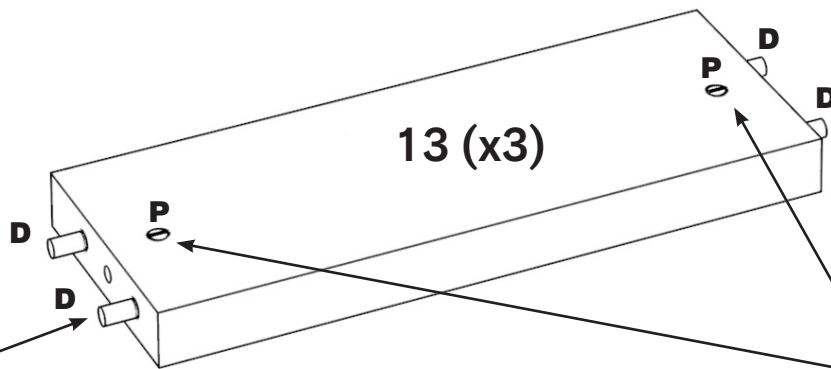
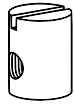



4 C x 04

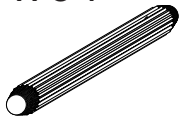

G x 02



3.5 x 15 mm.

U x 01

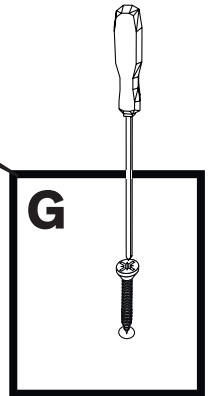
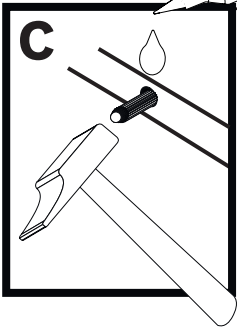
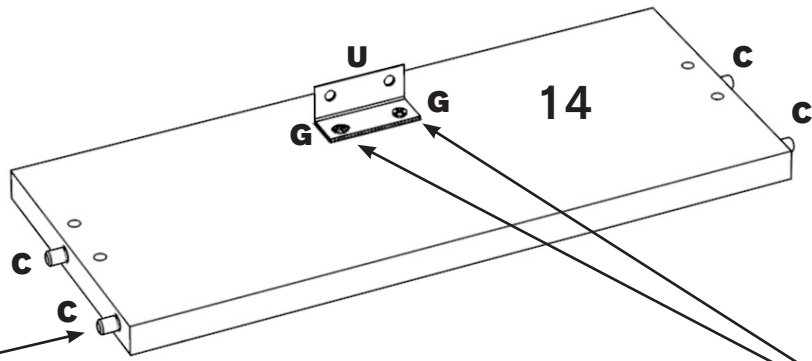
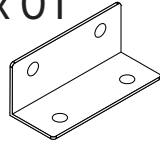

5 C x 04

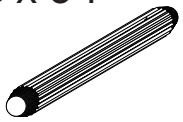

F x 04



AB x 02

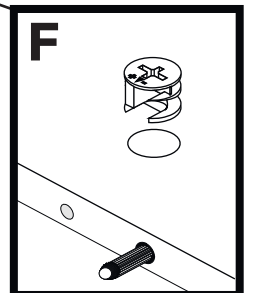
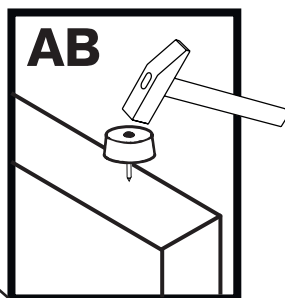
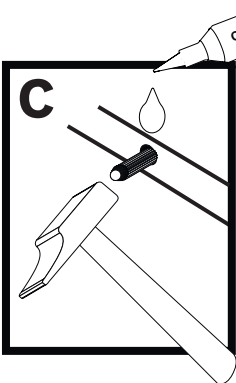
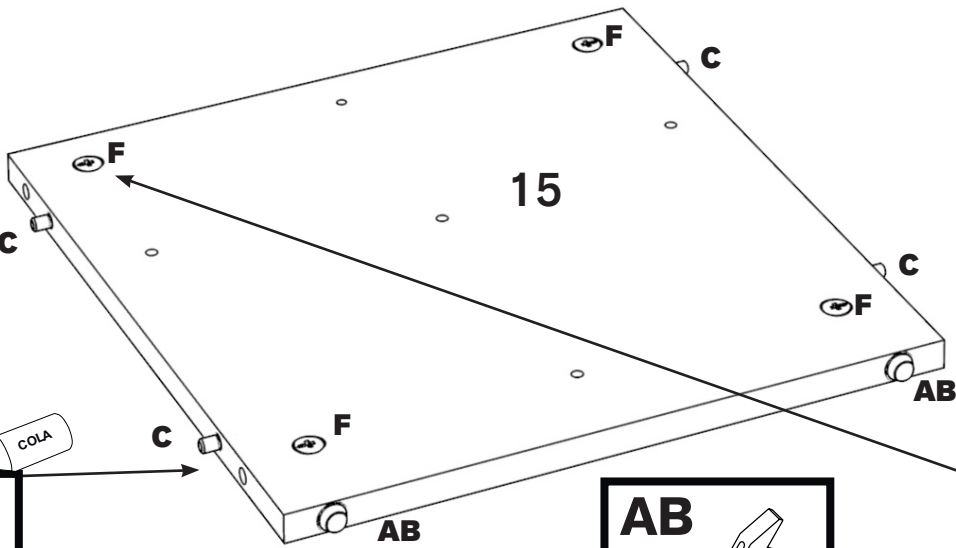
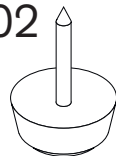

6 Ñ x 06

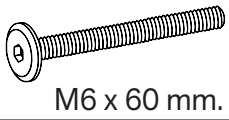

M6 x 60 mm.

AE x 01

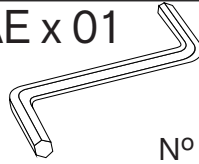

N° 4

AG x 04



17 mm.

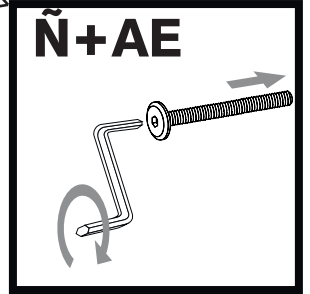
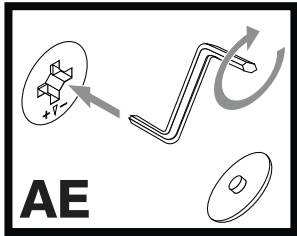
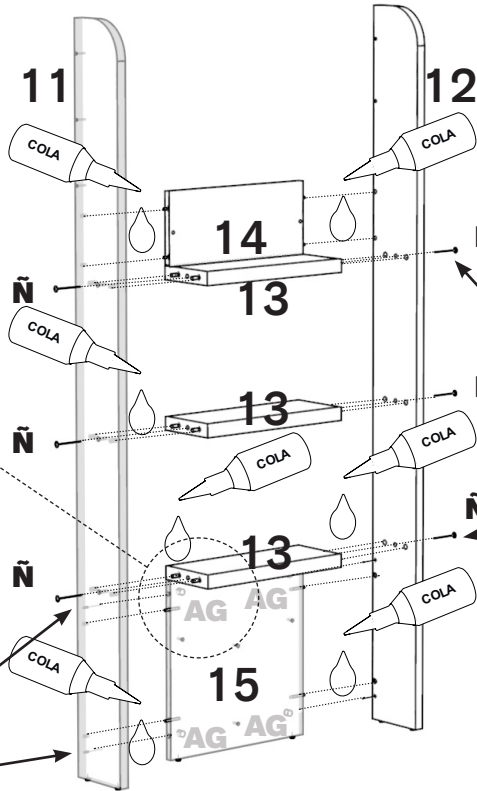
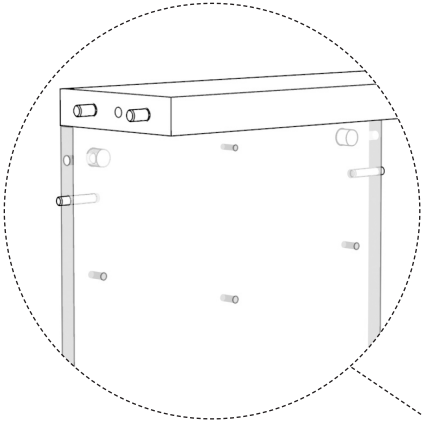

## Option A

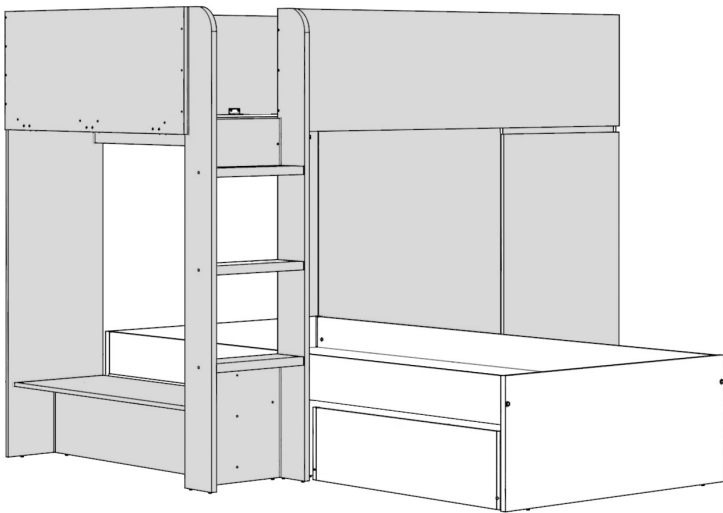

## Option B

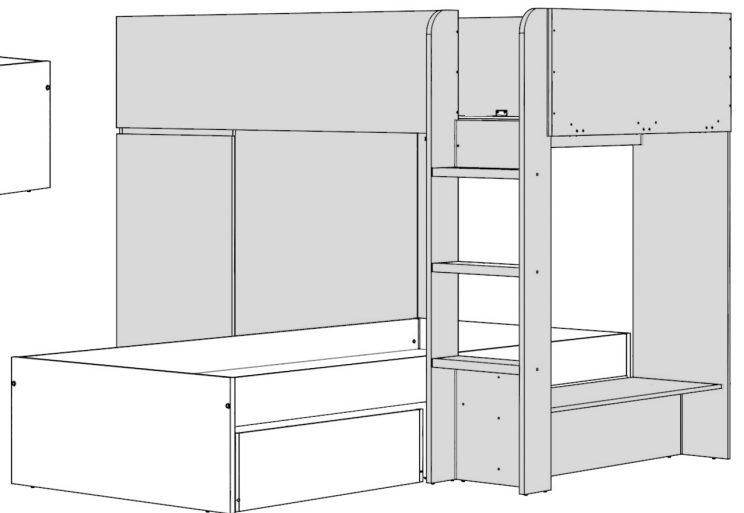

7 AB x 02

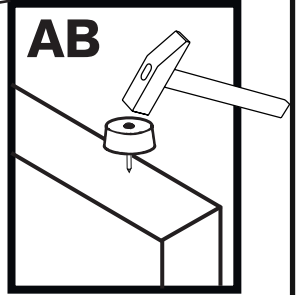
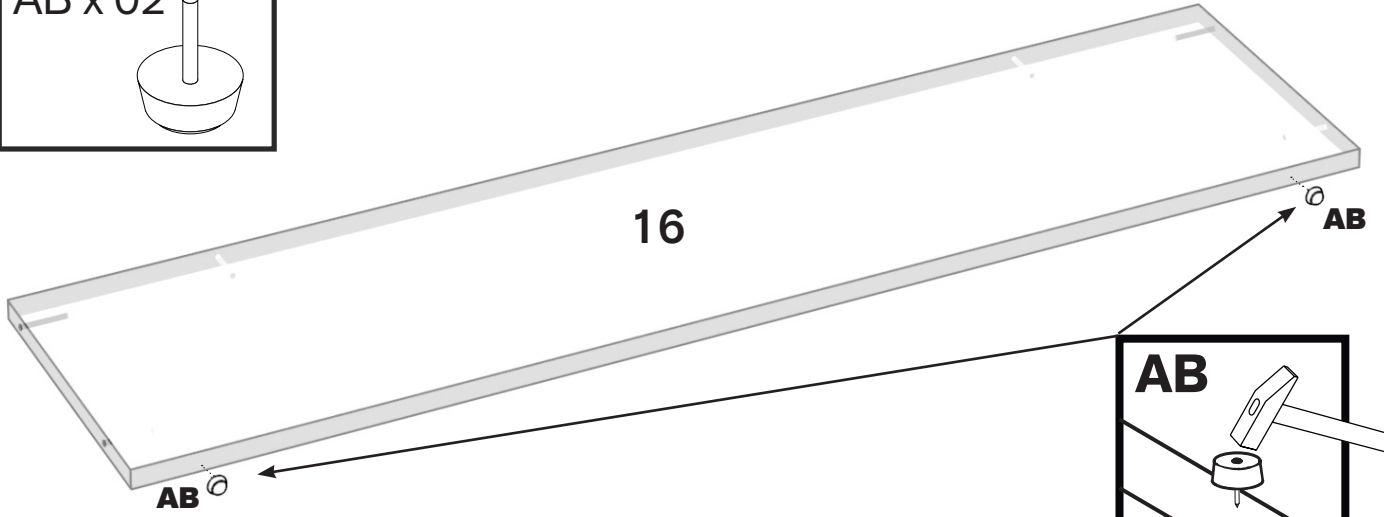
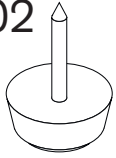

8 C x 01

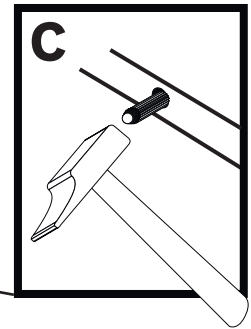
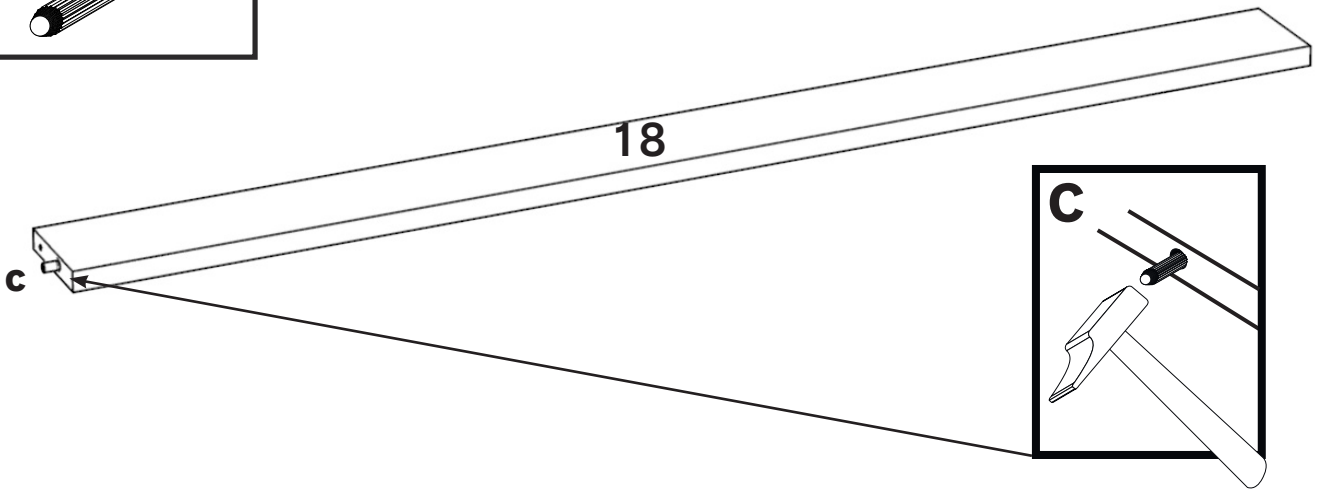
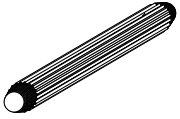

9 AB x 02

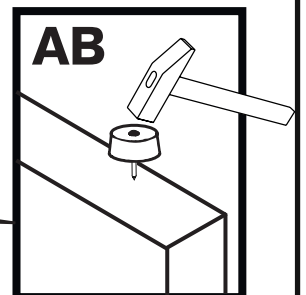
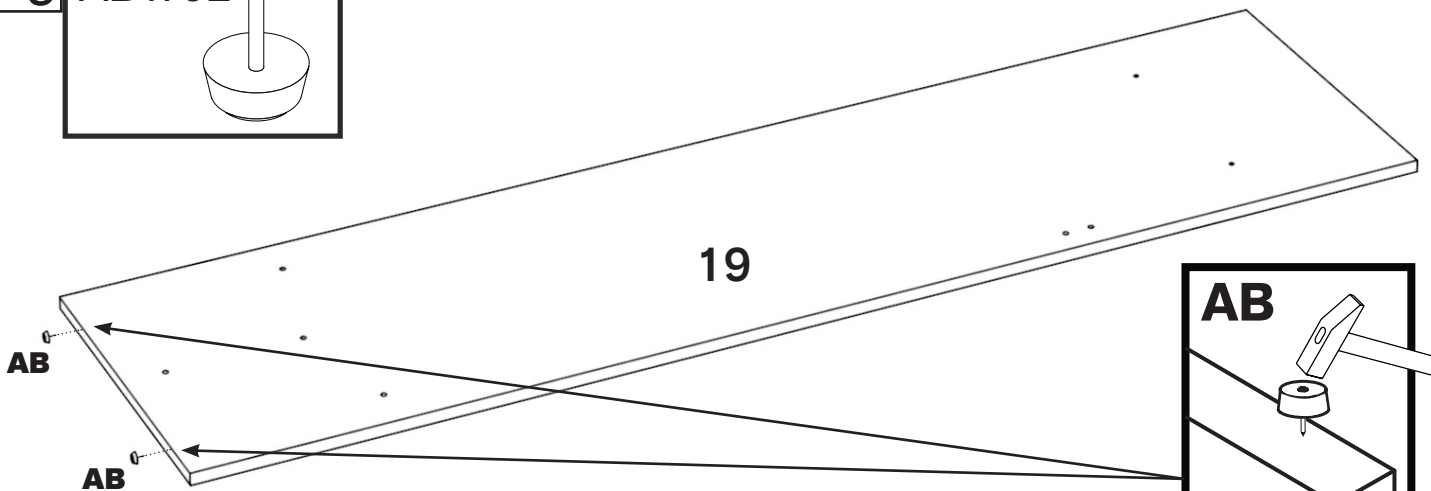
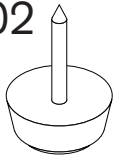

10

N x 13



5 x 60 mm.

AD x 01

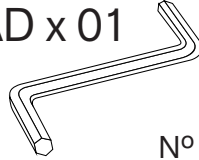

N° 3

AG x 10



17 mm.

# Option A

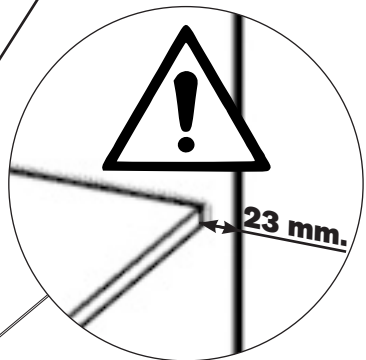
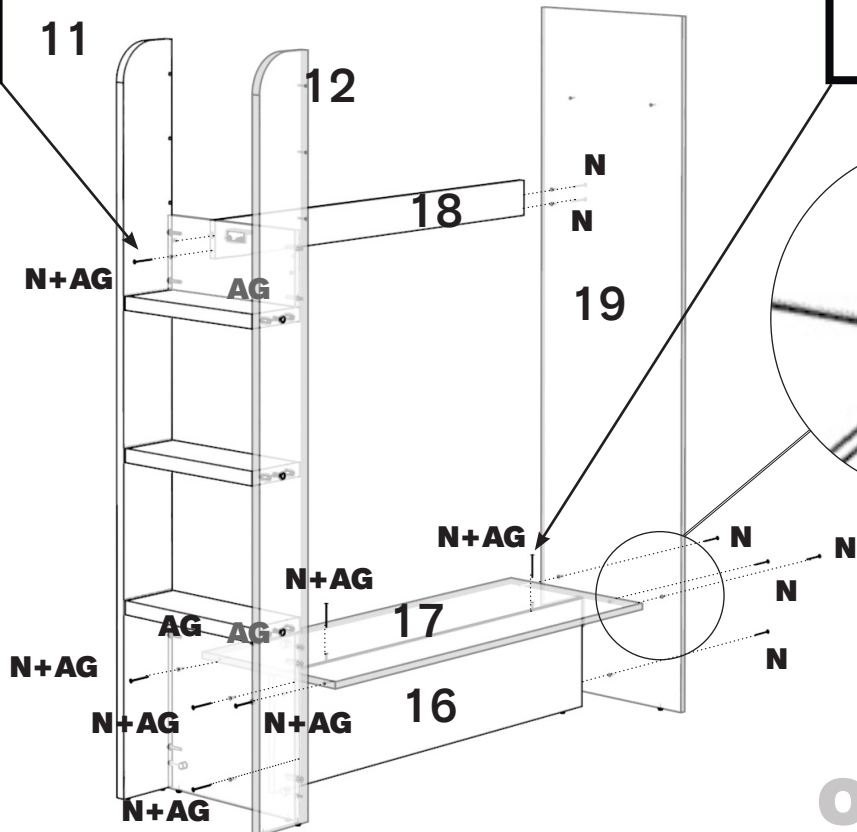
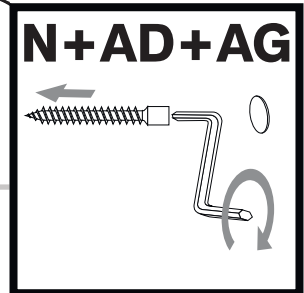
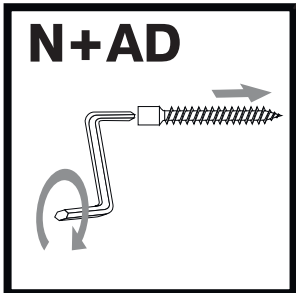
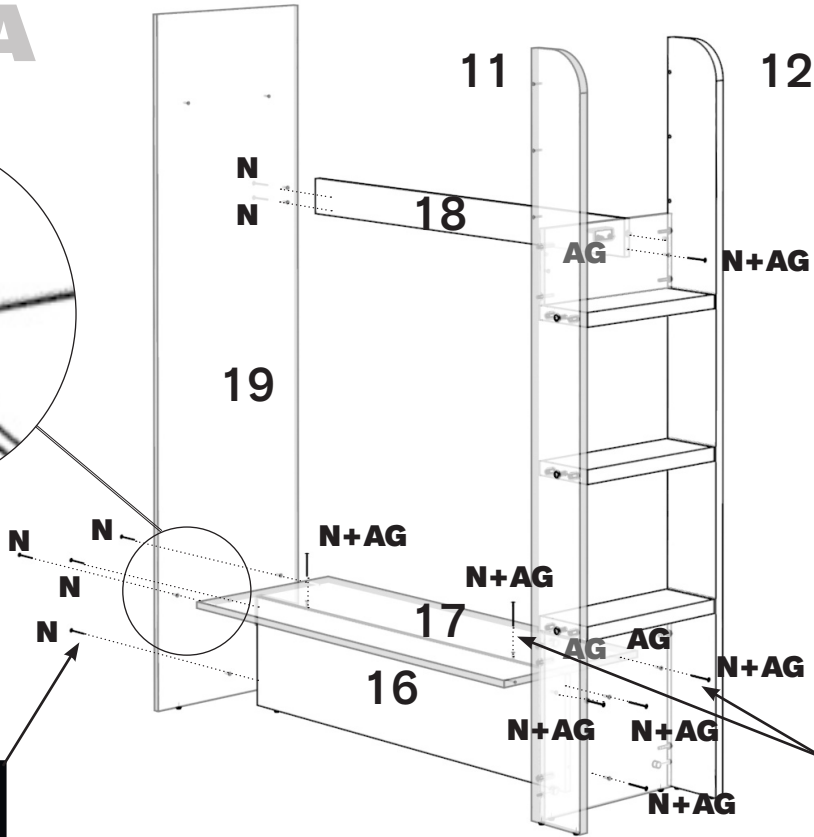
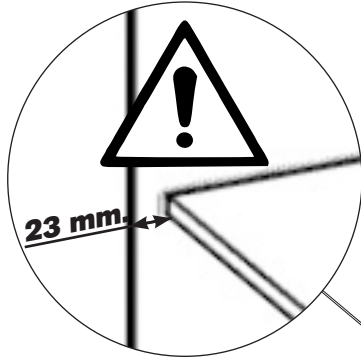

# Option B

11

G x 02

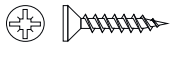

3.5 x 15 mm.

Z x 03



AA x 01

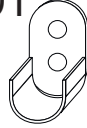

AB x 02



# Option A

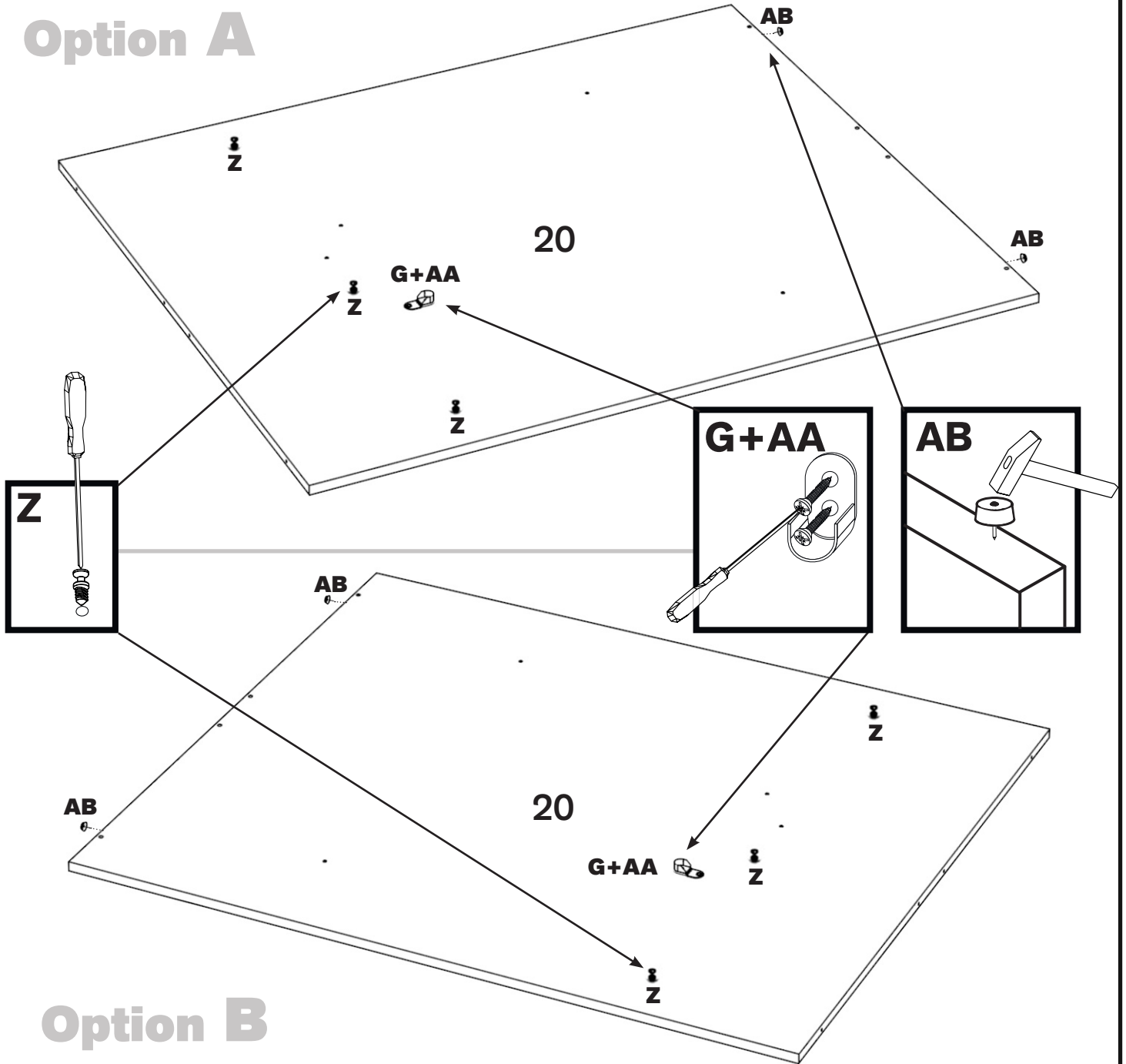

# Option B

12

AB x 02

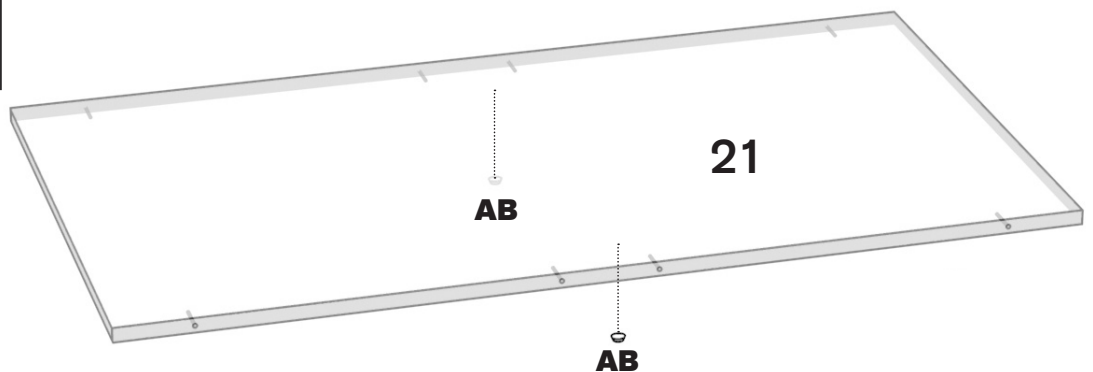
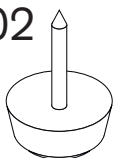

13

B x 03

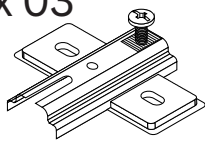

C x 02

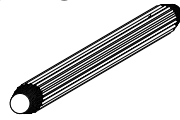

F x 03

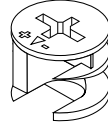

G x 08

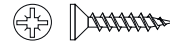

3.5 x 15 mm.

Z x 03

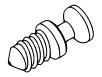

AA x 01

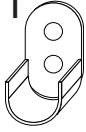

AB x 02

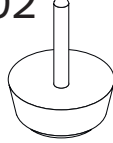

AG x 03



17 mm.

# Option A

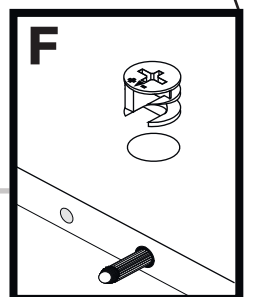
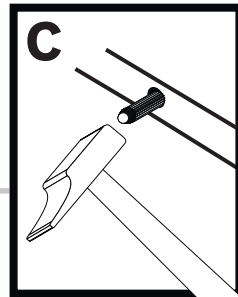
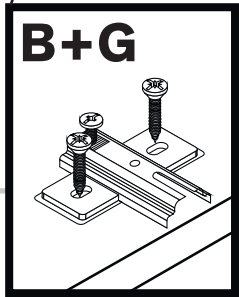
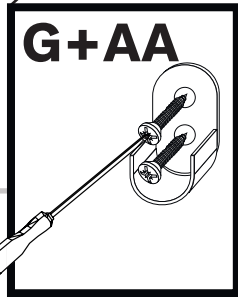
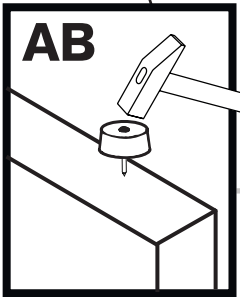
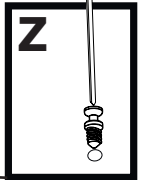
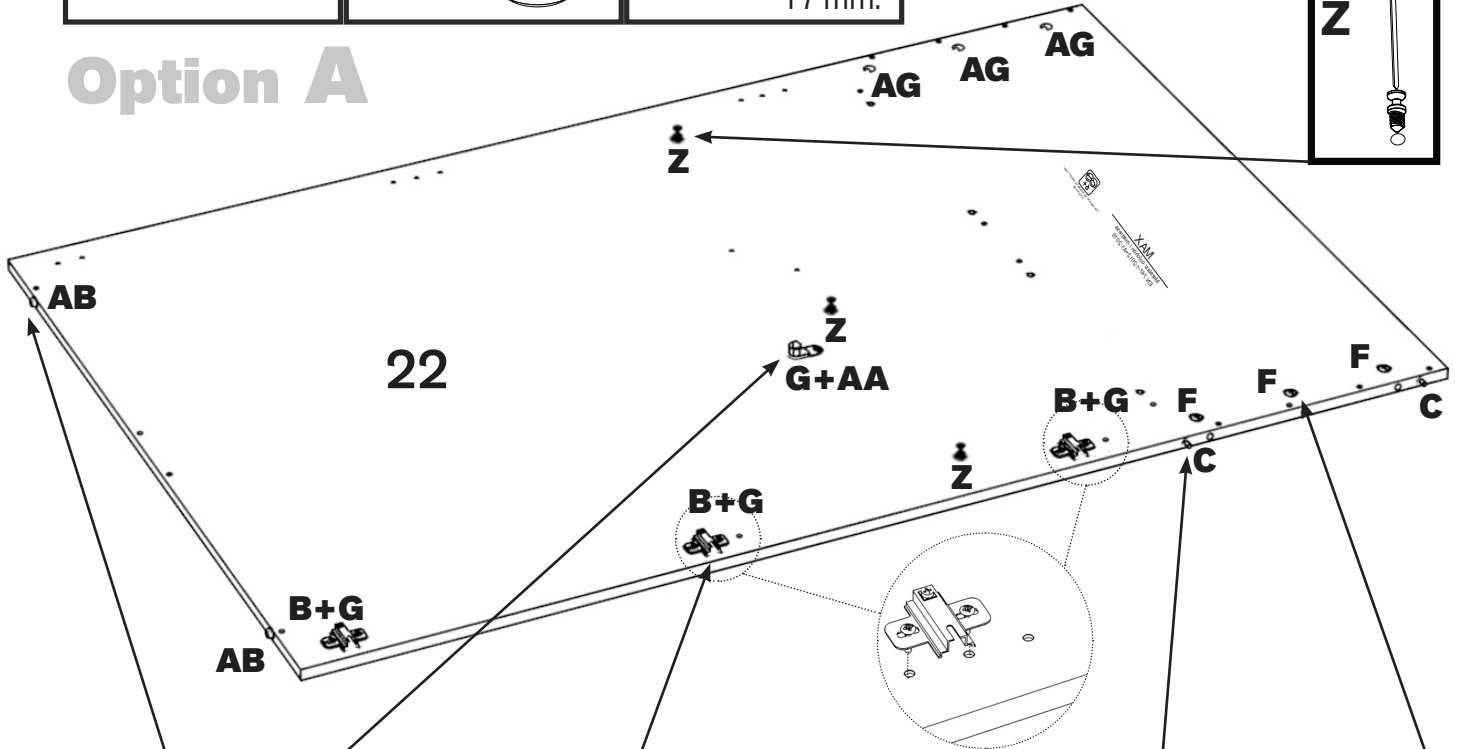

# Option B

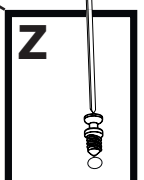
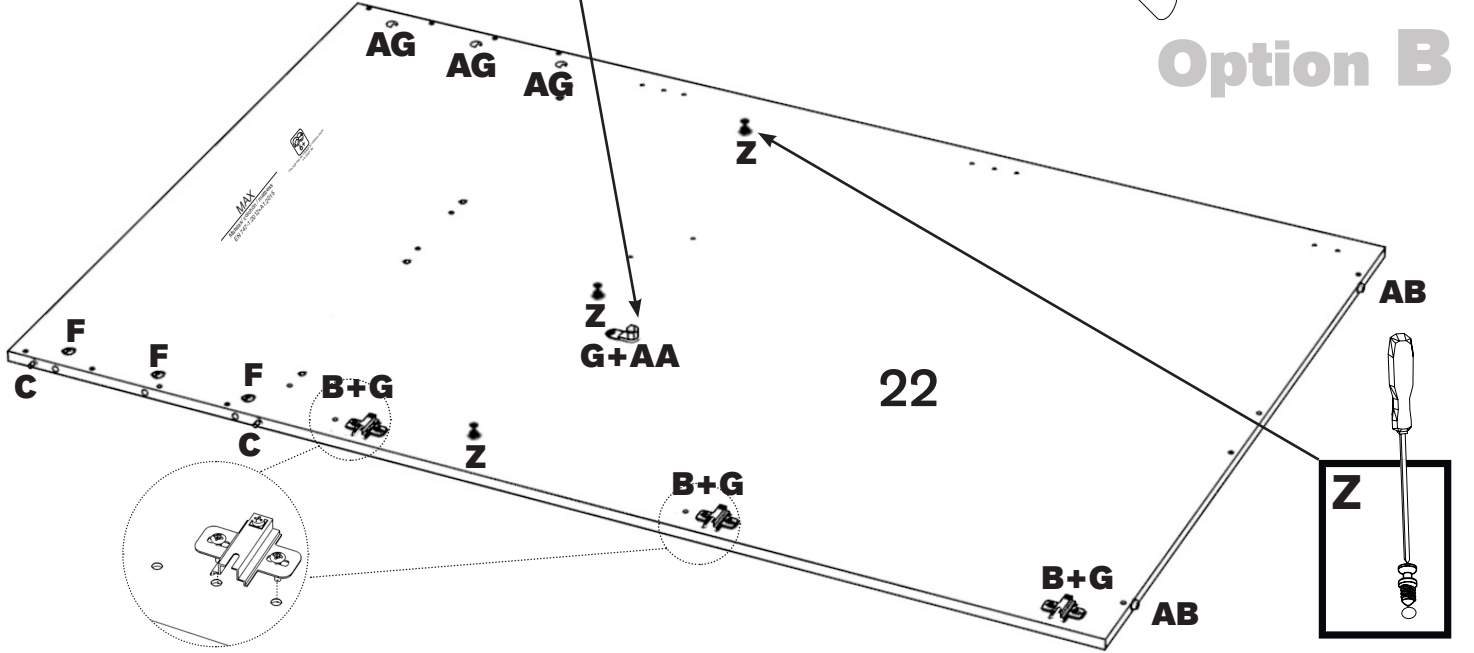

14

Y x 06

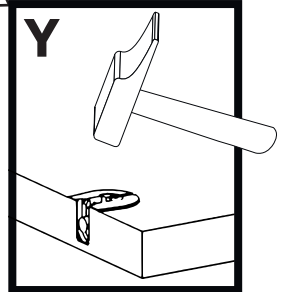
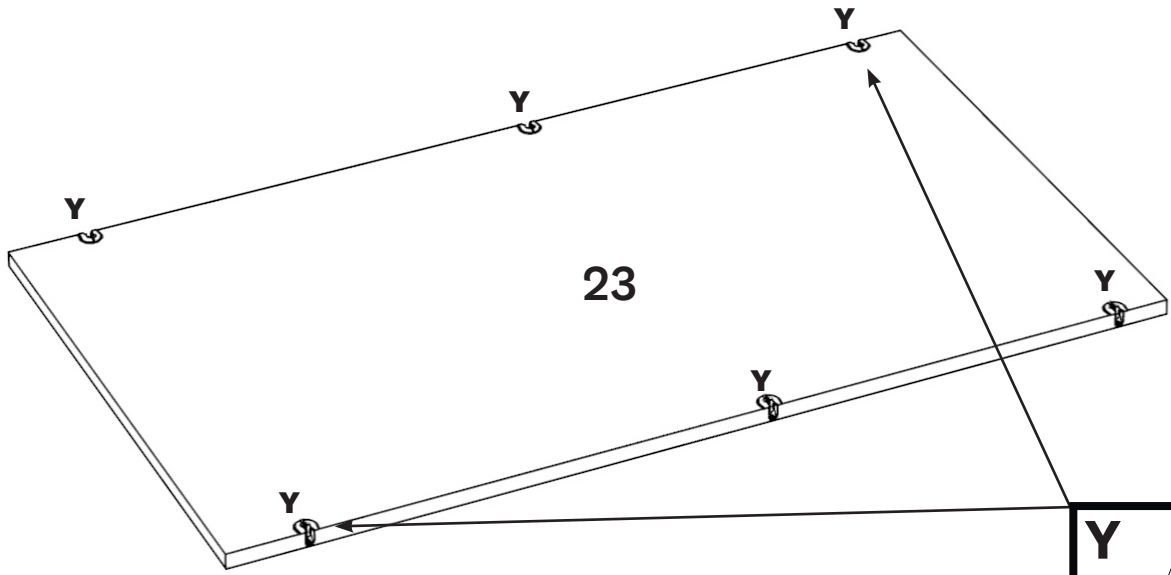
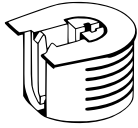

15

A x 03

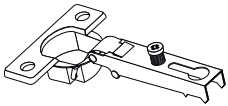

G x 06

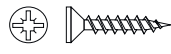

3.5 x 15 mm.

AH x 02



7 mm.

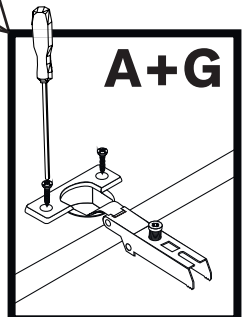
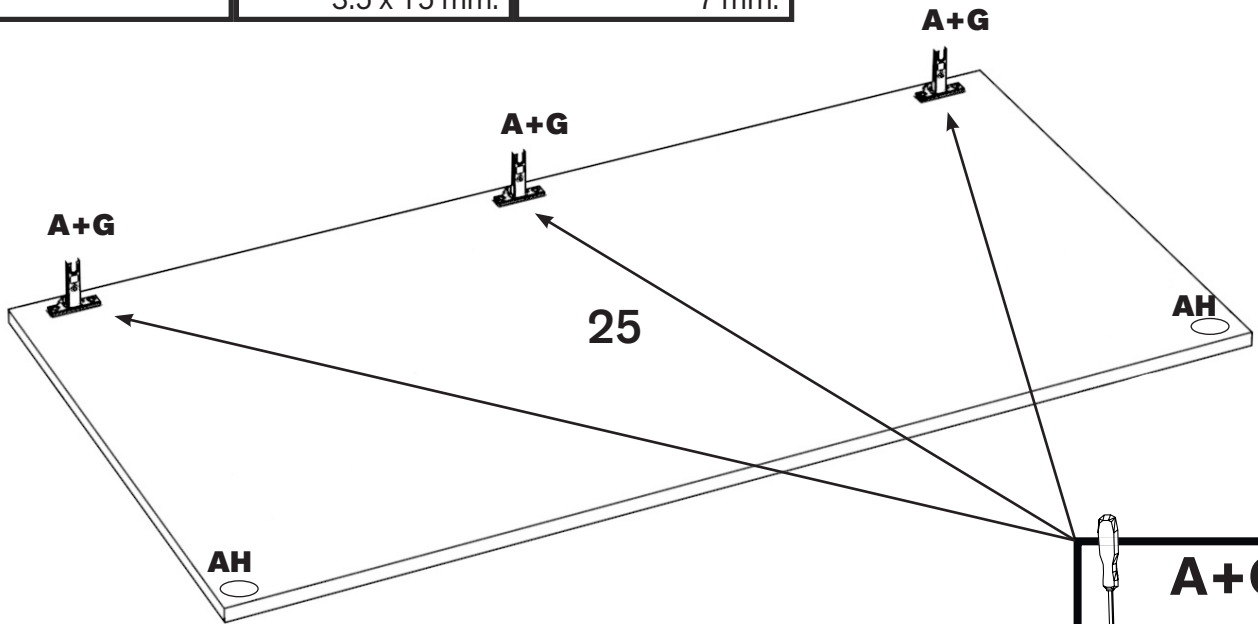

16

N x 08

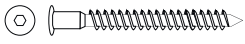

5 x 60 mm.

AD x 01

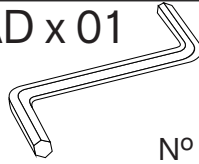

N° 3

AG x 04



17 mm.

# Option A

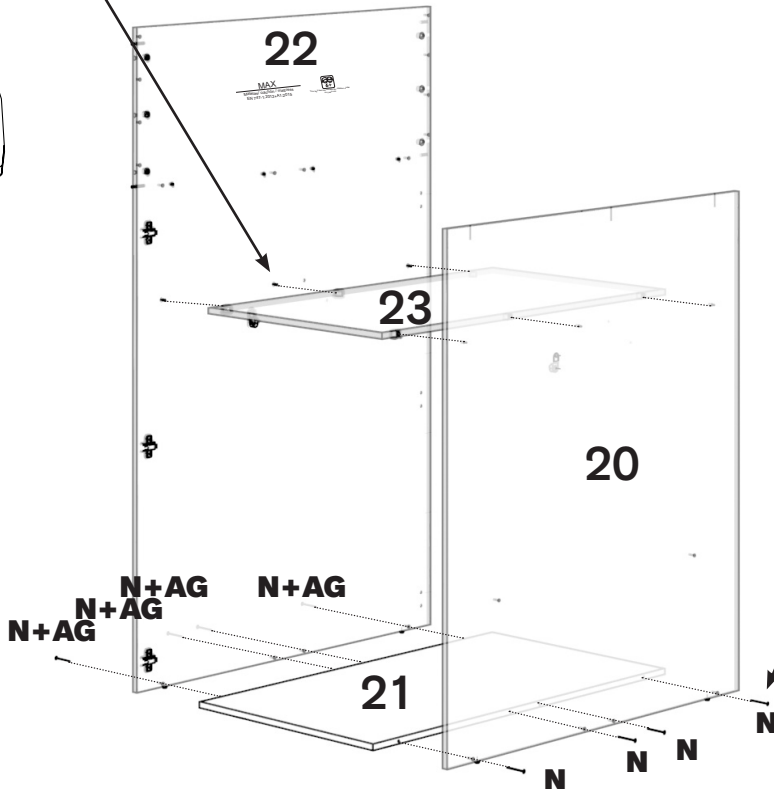
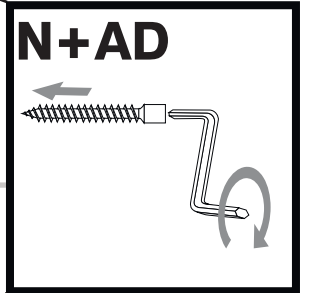
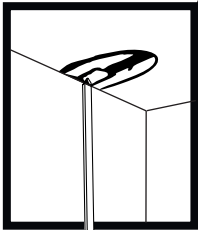
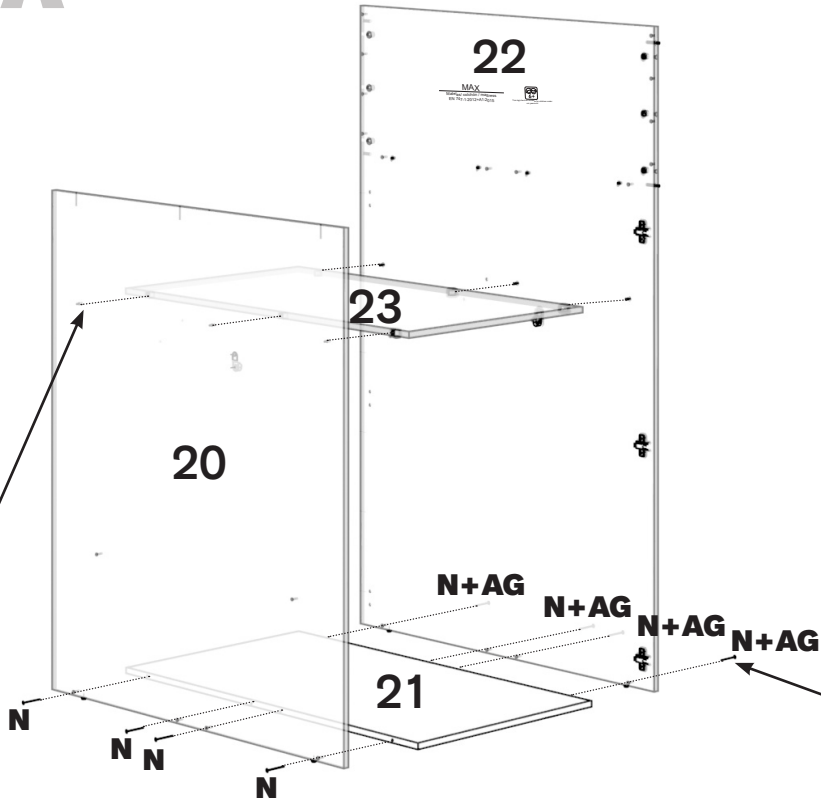

# Option B



17 C x 04

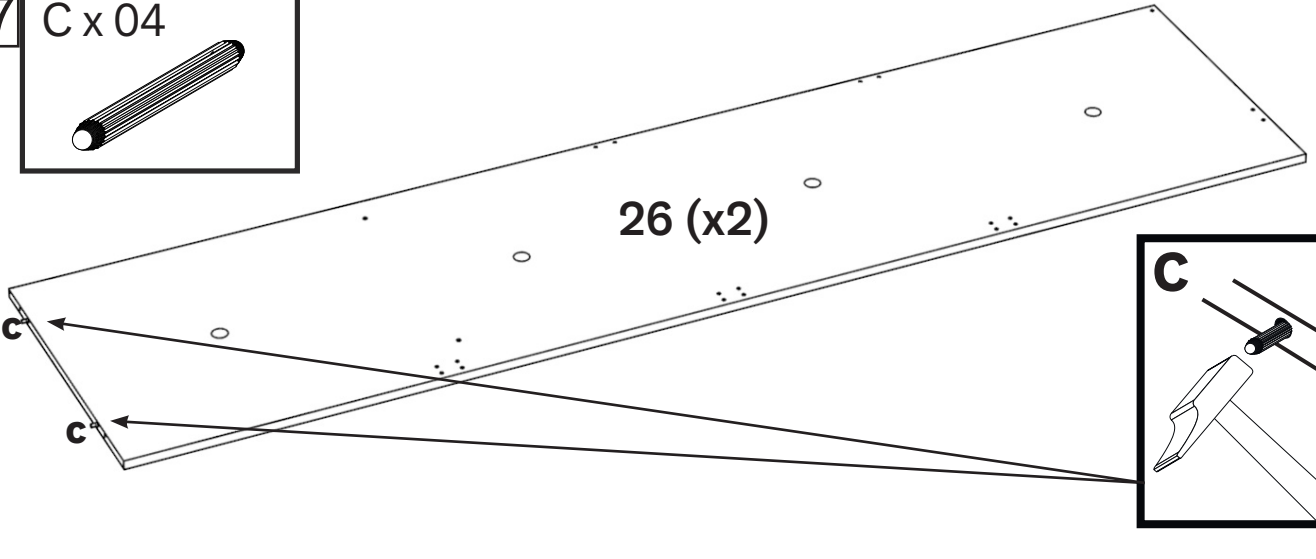
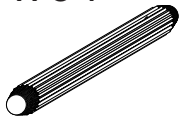

18 H x 04  
4 x 16 mm.



K x 06  
M4 x 10 mm.

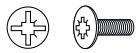

L x 06  
M4 x 15 mm.



U x 05

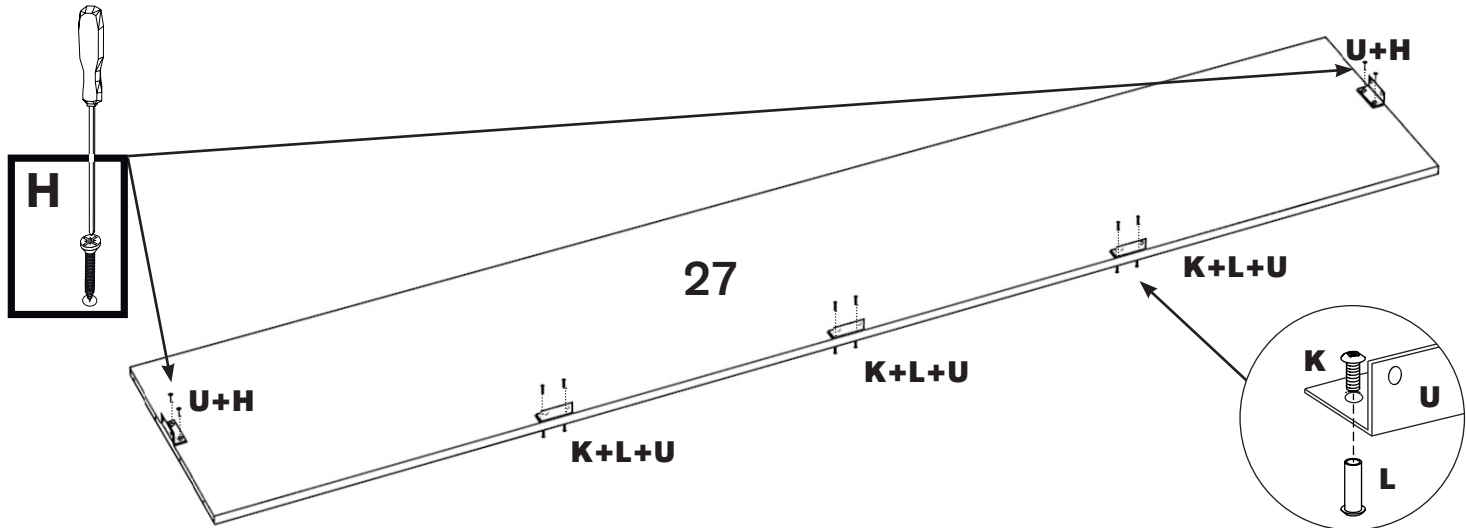
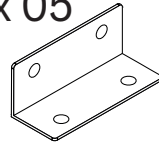

19 **Option A**

K x 06  
M4 x 10 mm.

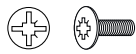

L x 06  
M4 x 15 mm.



U x 03

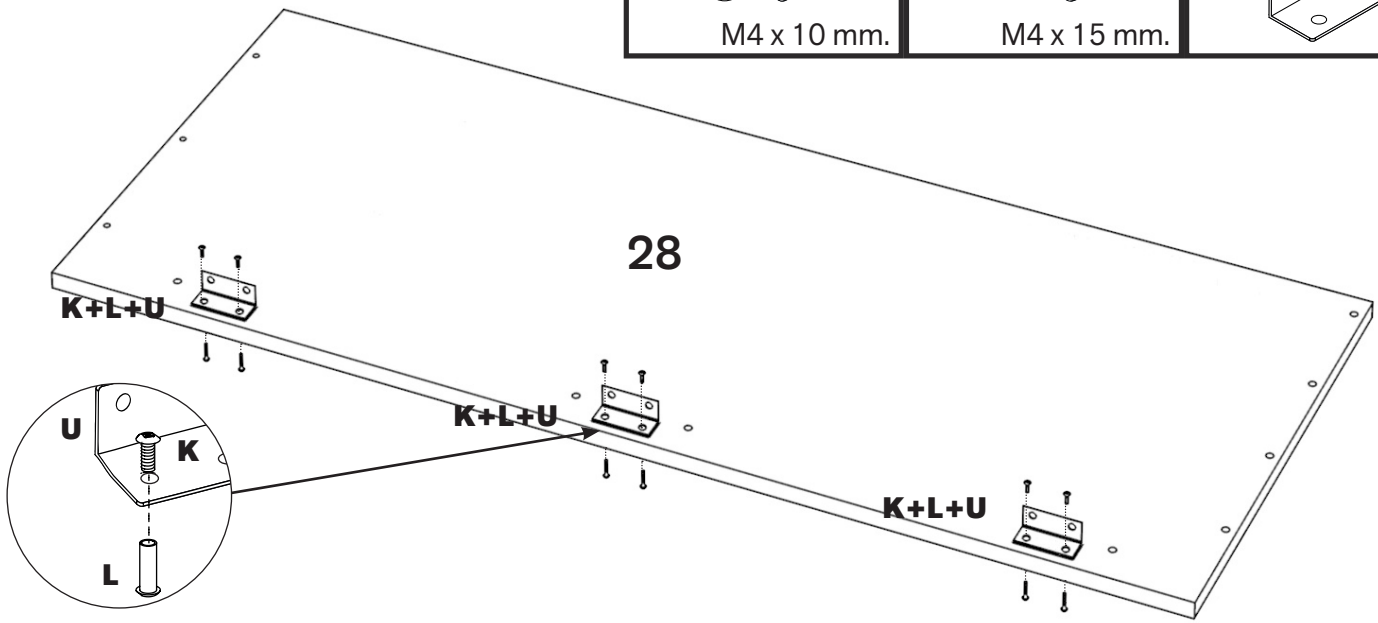
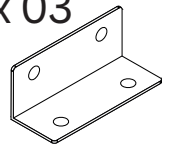

19

K x 06



M4 x 10 mm.

L x 06



M4 x 15 mm.

U x 03

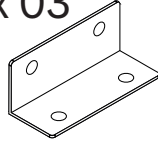

Option B

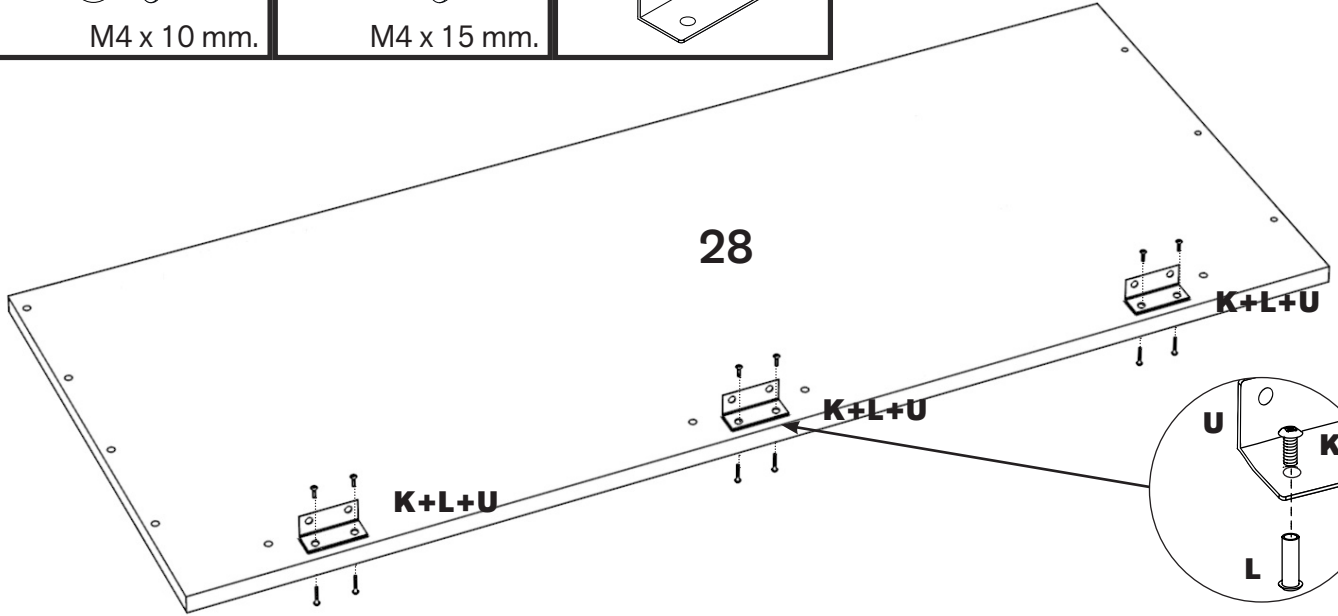

20

E x 03

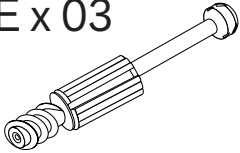

Y x 01

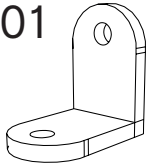

U x 03

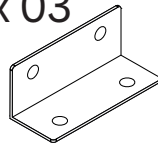

AK x 07

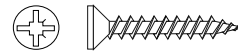

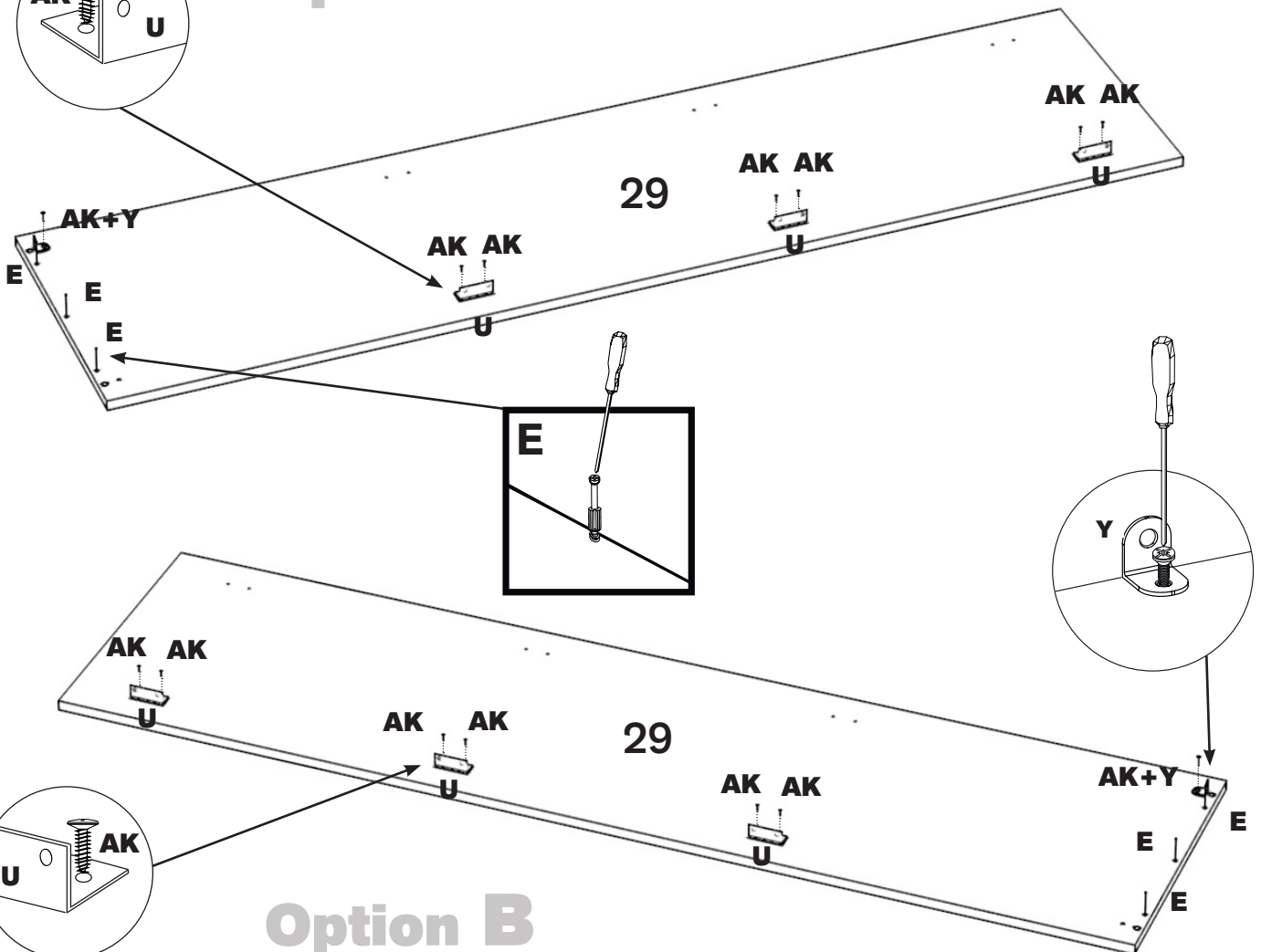
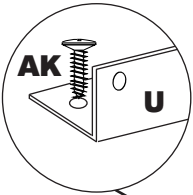

4 x 20 mm.

Option A

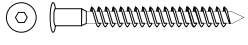
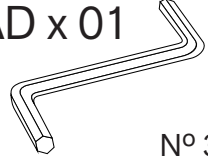

Option B

21	<b>N x 08</b>  5 x 60 mm.	<b>AD x 01</b>  Nº 3	<b>AG x 08</b>  17 mm.
----	--	---	---

## Option A

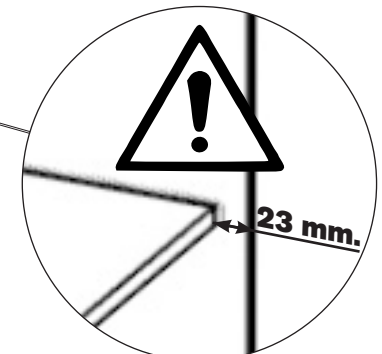
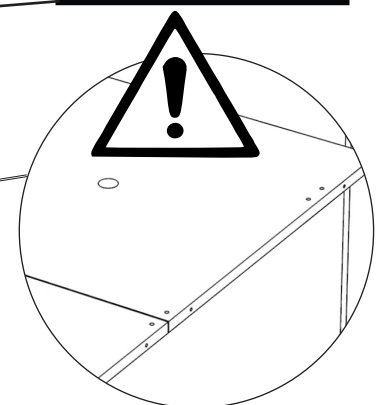
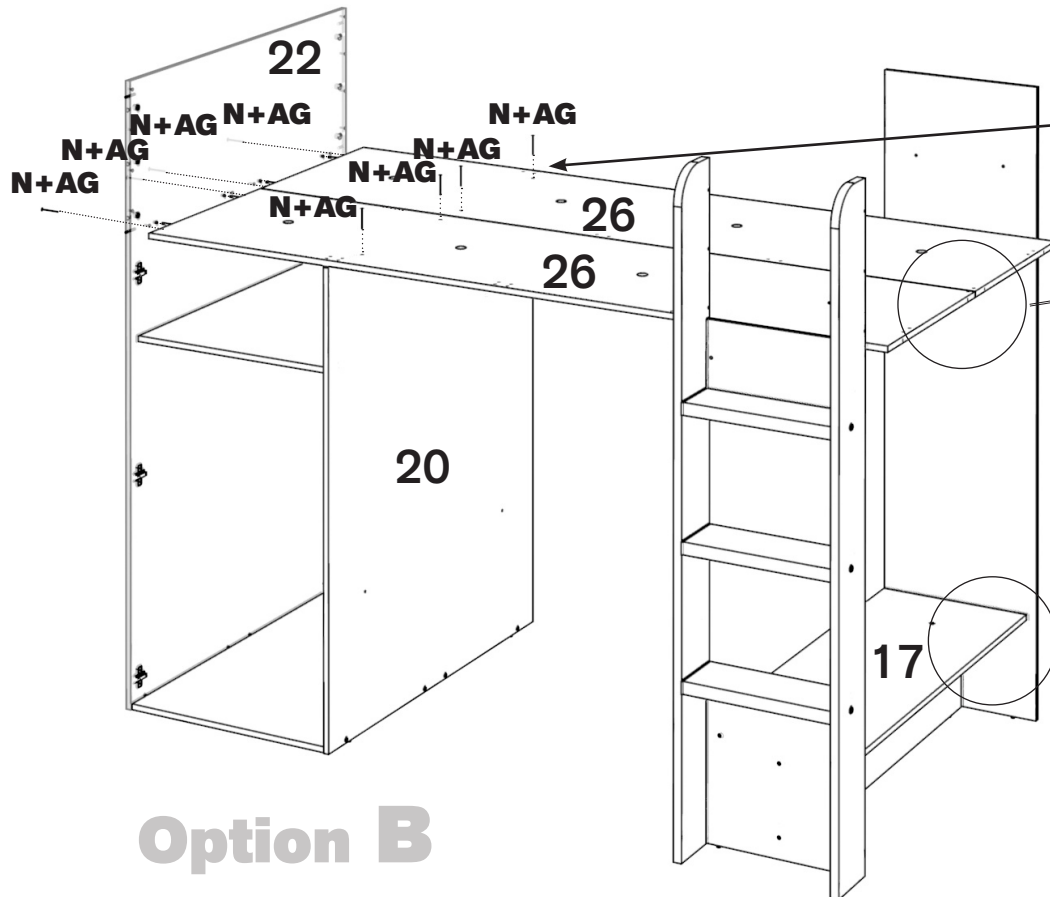
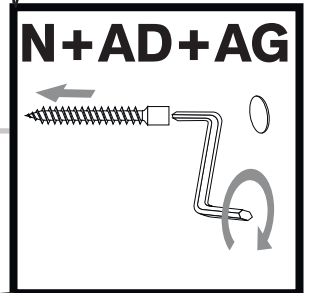
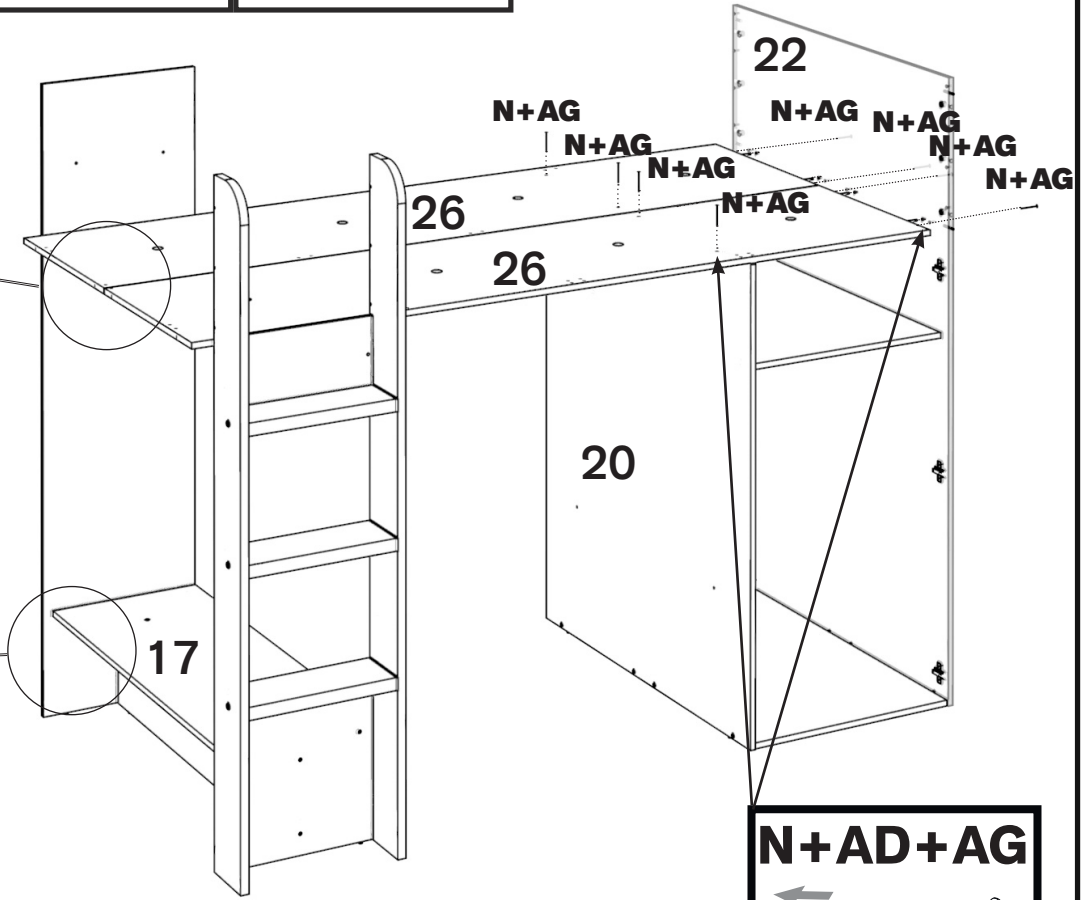
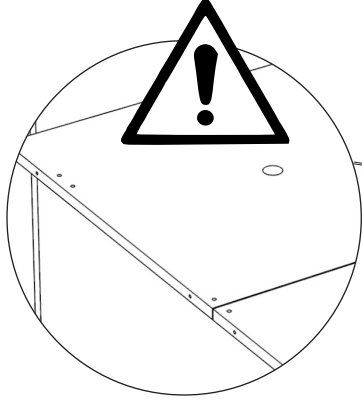

## Option B

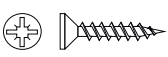
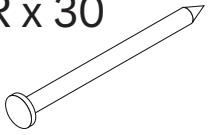
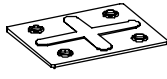

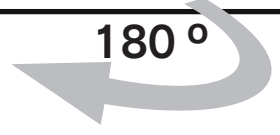
22	<b>G x 08</b>  3.5 x 15 mm.	<b>R x 30</b> 	<b>V x 02</b> 
----	--	--	--

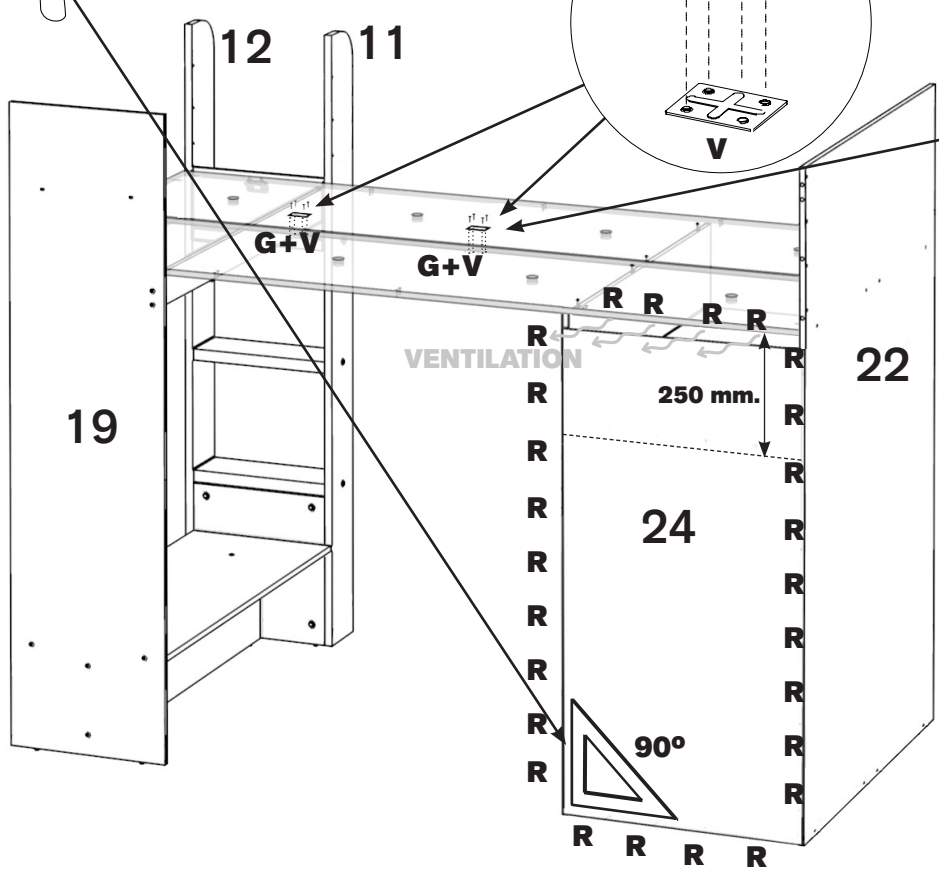
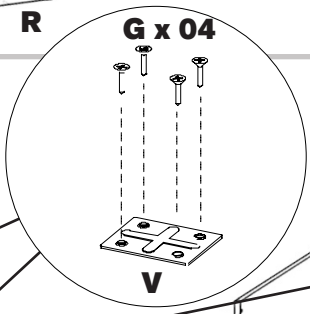
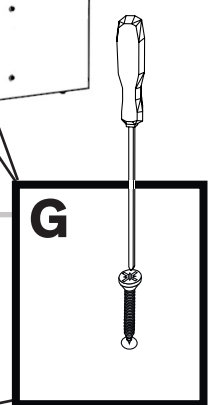
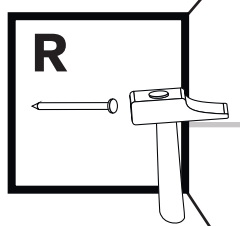
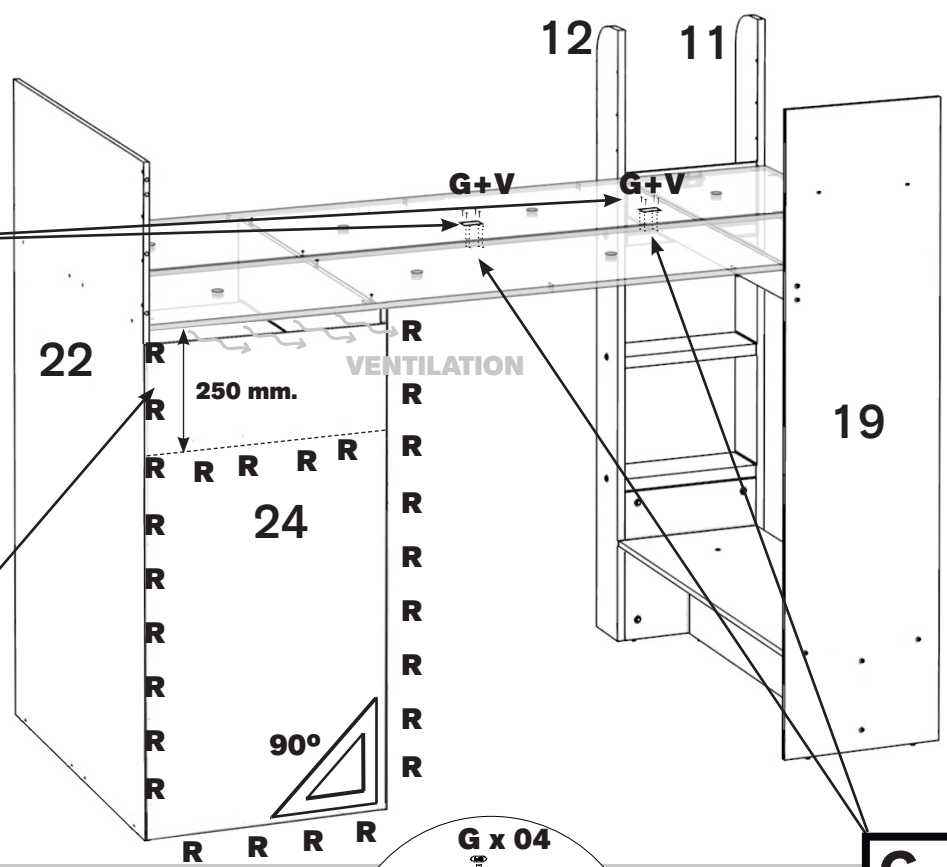
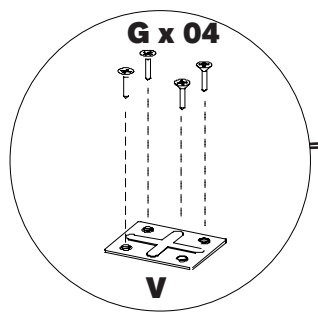

# Option A

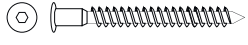
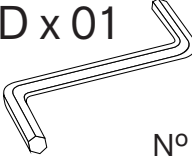
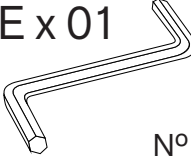

# Option B

<b>23</b> N x 07  5 x 60 mm.	AD x 01  Nº 3	AE x 01  Nº 4	AG x 18  17 mm.
---	--	--	--

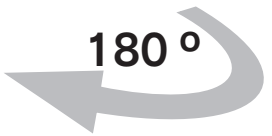

# Option A

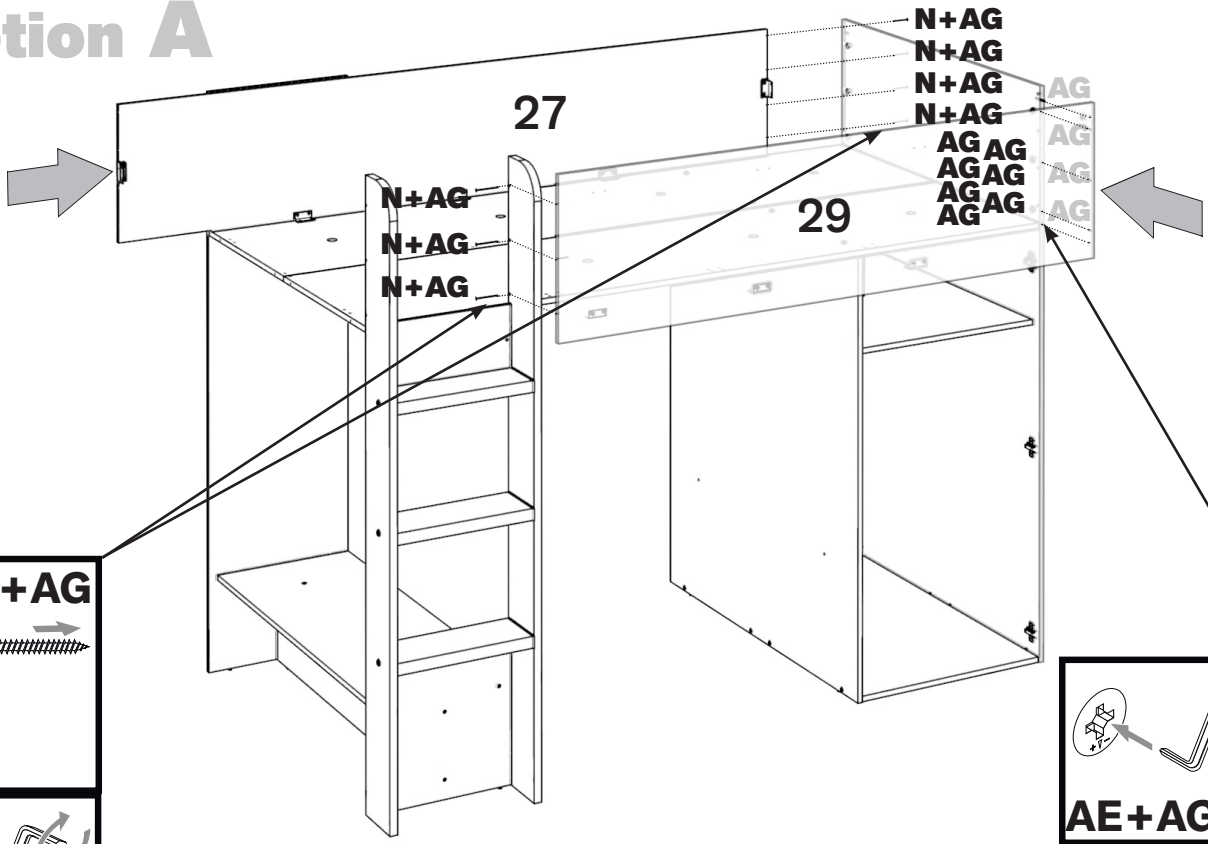

**N+AD+AG**

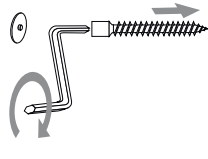

**AE+AG**

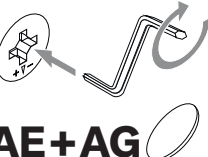



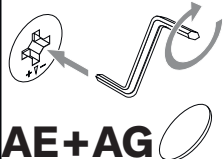
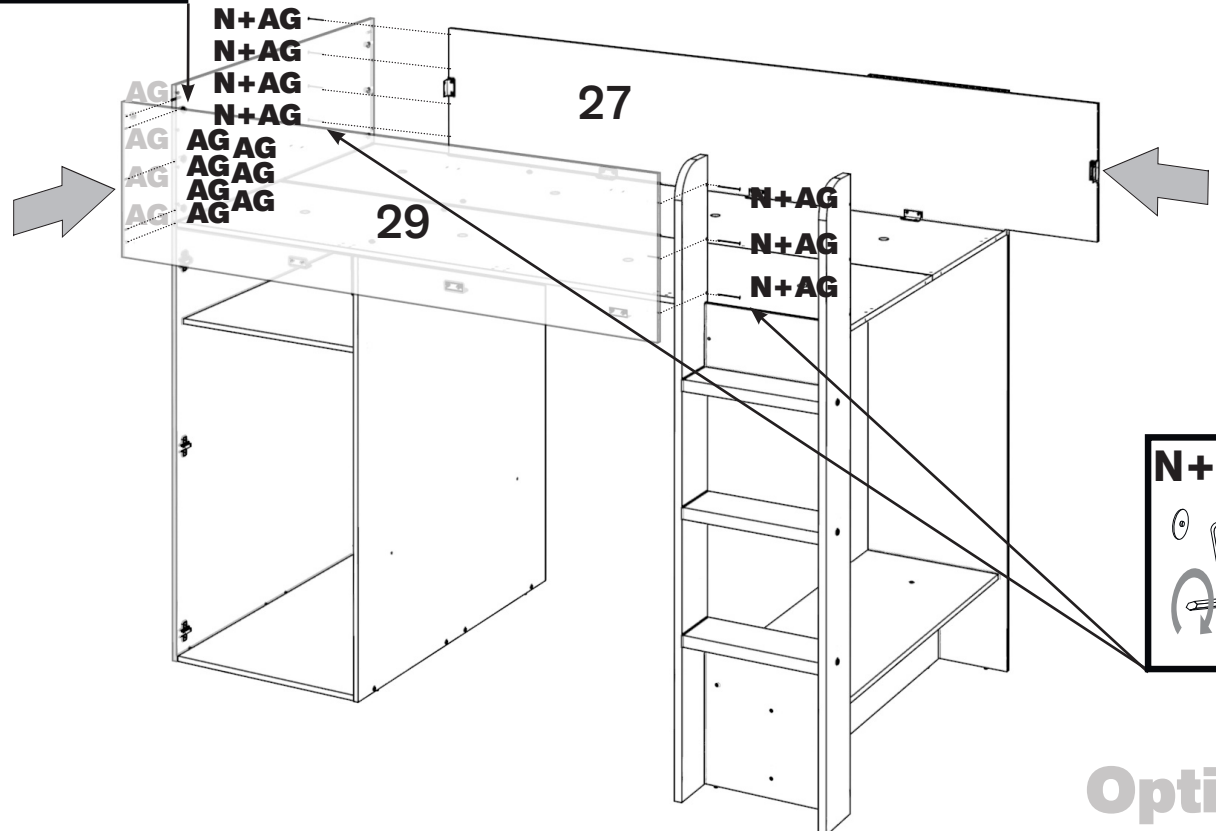

**AE+AG**

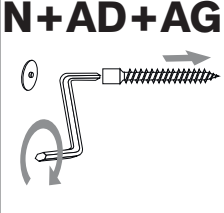

**N+AD+AG**





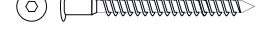

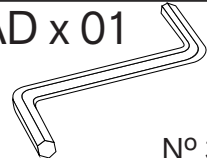

# Option B

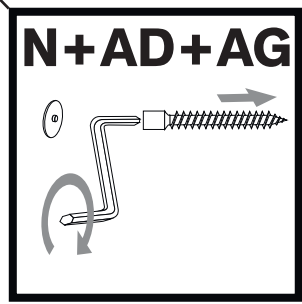
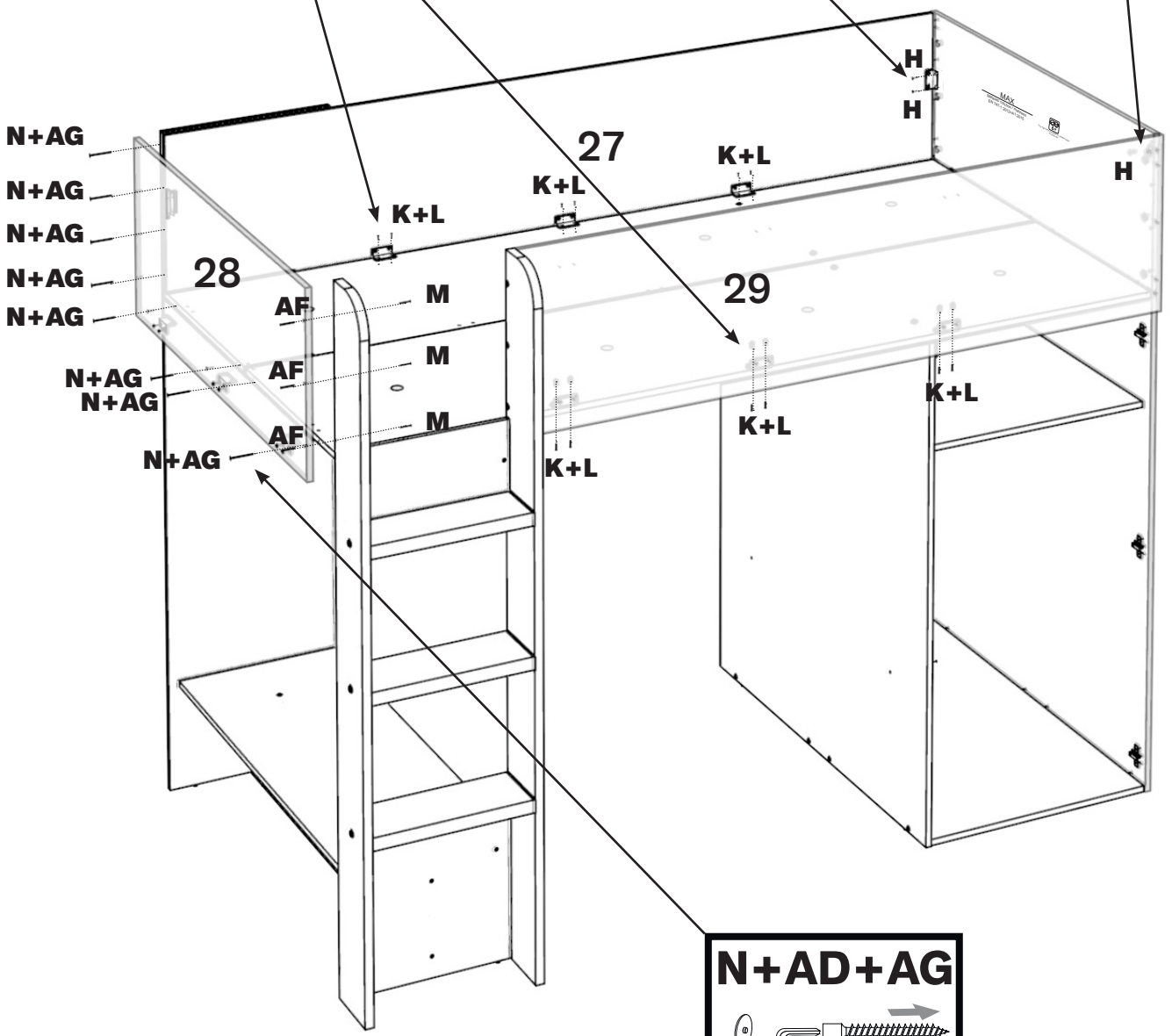
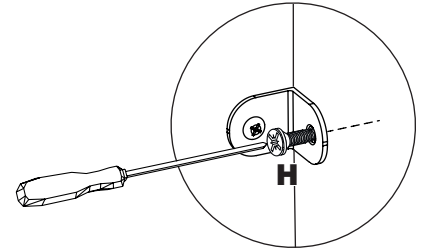
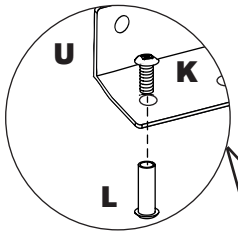
<b>24</b> H x 03  4 x 16 mm.	K x 12  M4 x 10 mm.	L x 12  M4 x 15 mm.	M x 03  M4 x 15 mm.	N x 08  5 x 60 mm.
---	--	--	--	---

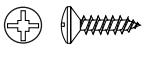

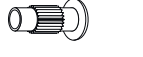

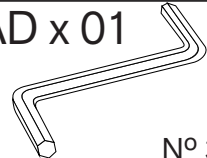
# Option A

AD x 01  N° 3	AF x 03  M4 X 30 mm.	AG x 08  17 mm.
--	---	--

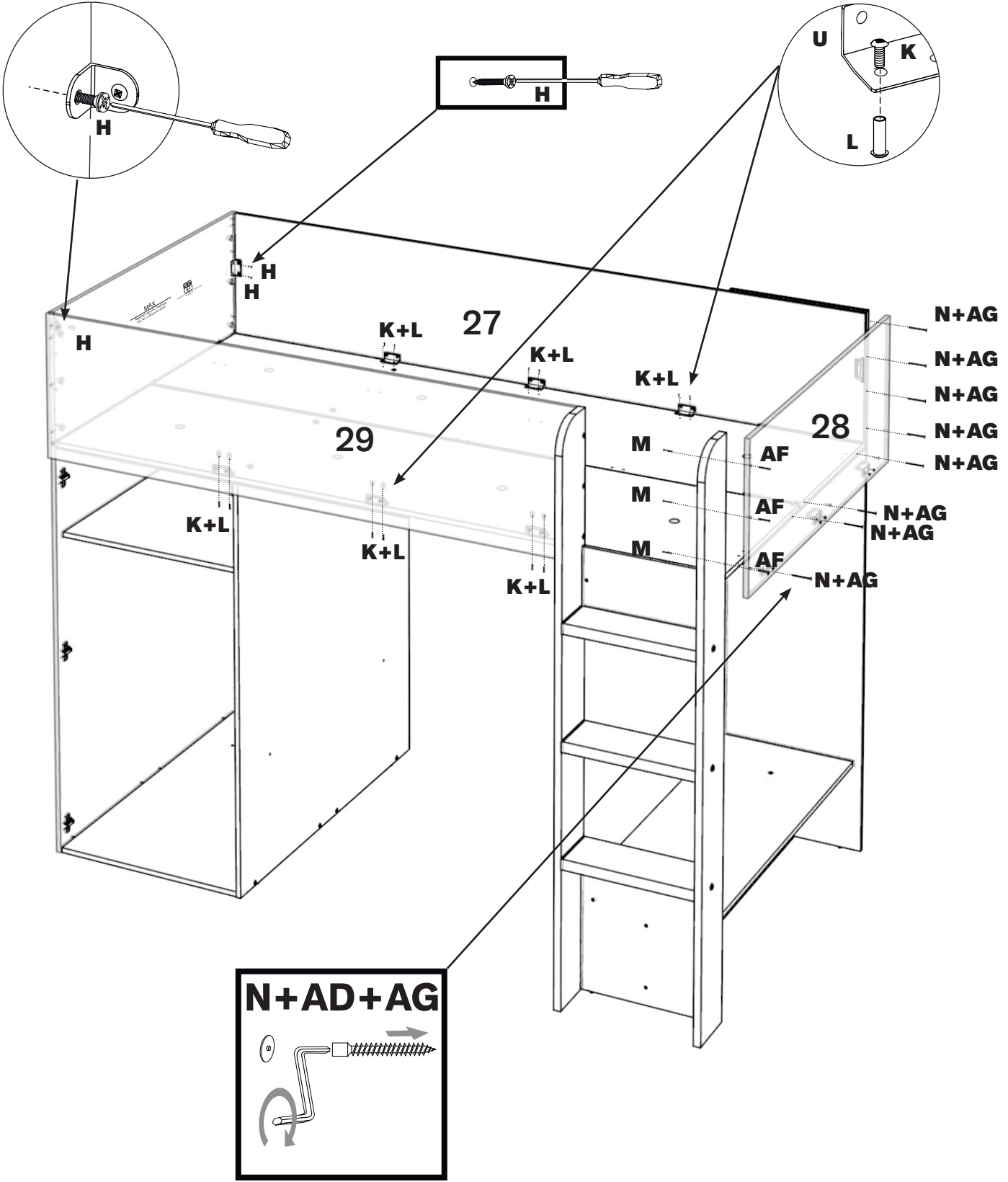

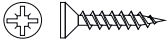
<b>24</b> H x 03  4 x 16 mm.	K x 12  M4 x 10 mm.	L x 12  M4 x 15 mm.	M x 03  M4 x 15 mm.	N x 08  5 x 60 mm.
<b>Option B</b>		AD x 01  N° 3	AF x 03  M4 X 30 mm.	AG x 08  17 mm.

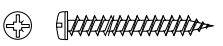

<b>25</b> G x 02  3.5 x 15 mm.	H x 02  4 x 16 mm.	J x 02  4 x 30 mm.	K x 06  M4 x 10 mm.	L x 06  M4 x 15 mm.
---	---	---	--	--

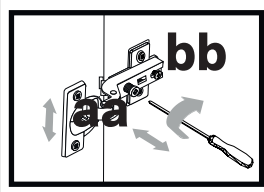
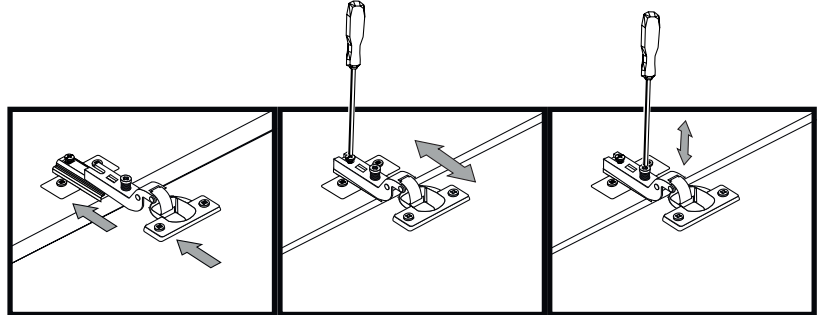
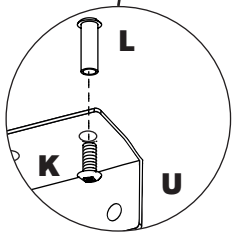
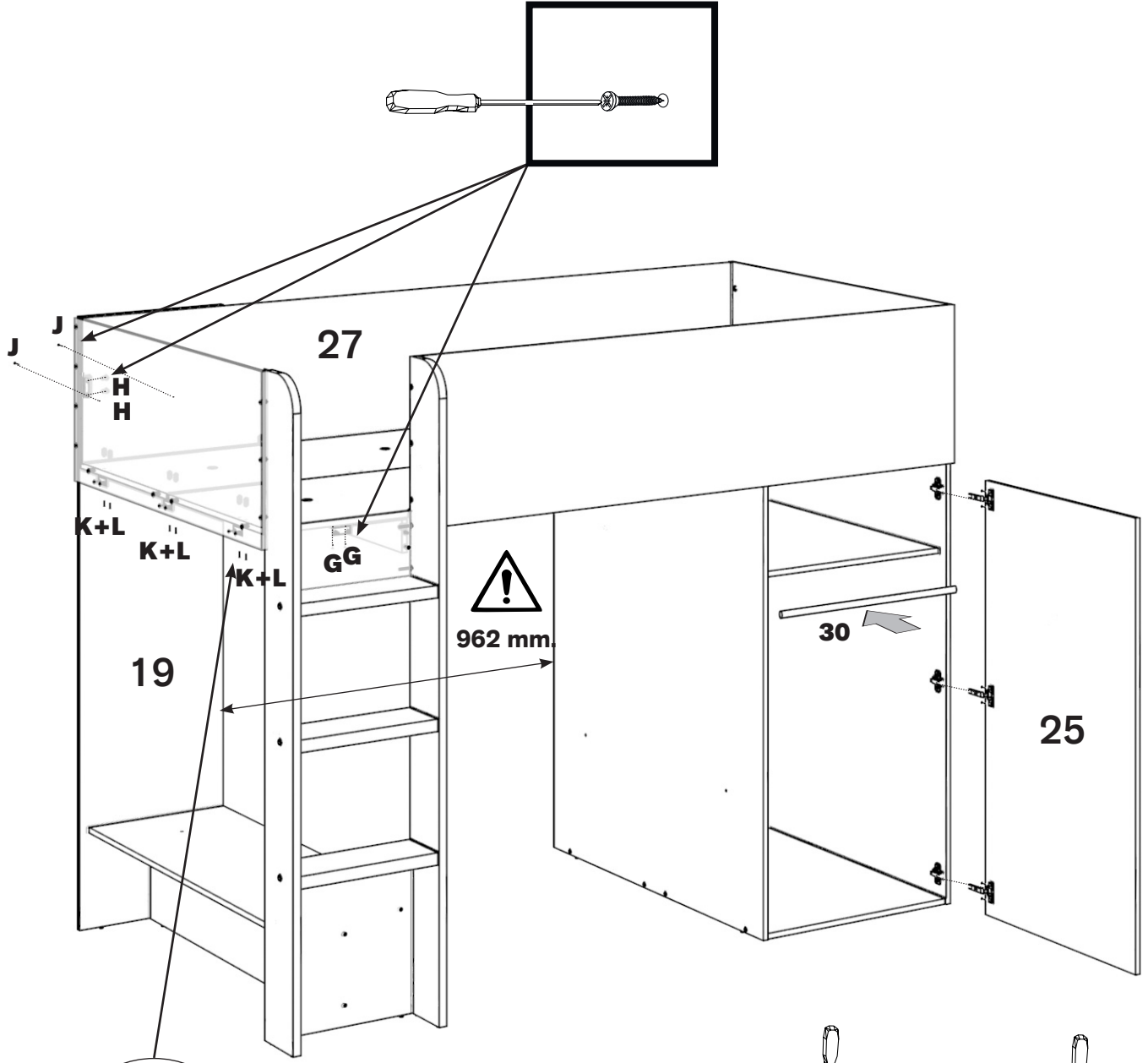

# Option A



**EN**  
 Before to tighten the screw "aa", you have to slacken a little the screw "bb"  
**ES**  
 Antes de apretar el tornillo "aa", hay que aflojar un poco el tornillo "bb"  
**FR**  
 Avant de presser le vis "aa", il y a que relâcher un peu le vis "bb"

**PT**  
 Antes de apertar o parafuso "aa", deve desapertar um pouco o parafuso "bb"  
**NL**  
 Voordat de schroef "aa" wordt vastgedraaid, moet de schroef "bb" enigszins worden losgedraaid  
**DE**  
 Bevor die Schraube "aa" festgezogen wird lösen Sie ein wenig die schraub "bb"

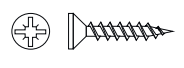
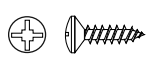
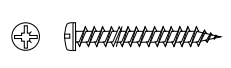

<b>25</b> G x 02  3.5 x 15 mm.	H x 02  4 x 16 mm.	J x 02  4 x 30 mm.	K x 06  M4 x 10 mm.	L x 06  M4 x 15 mm.
---	---	---	--	--

# Option B

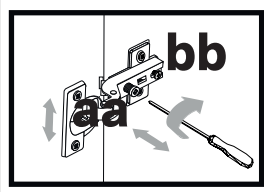
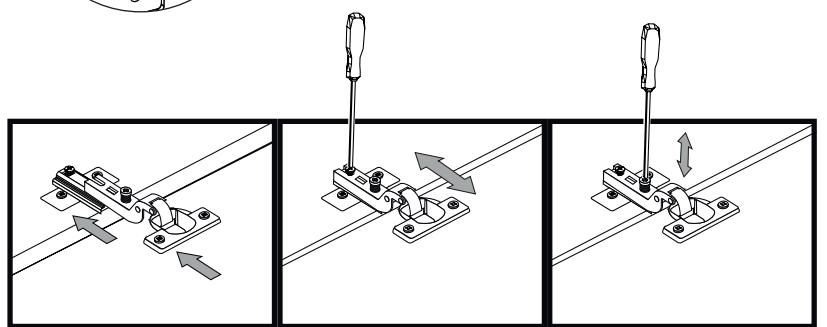
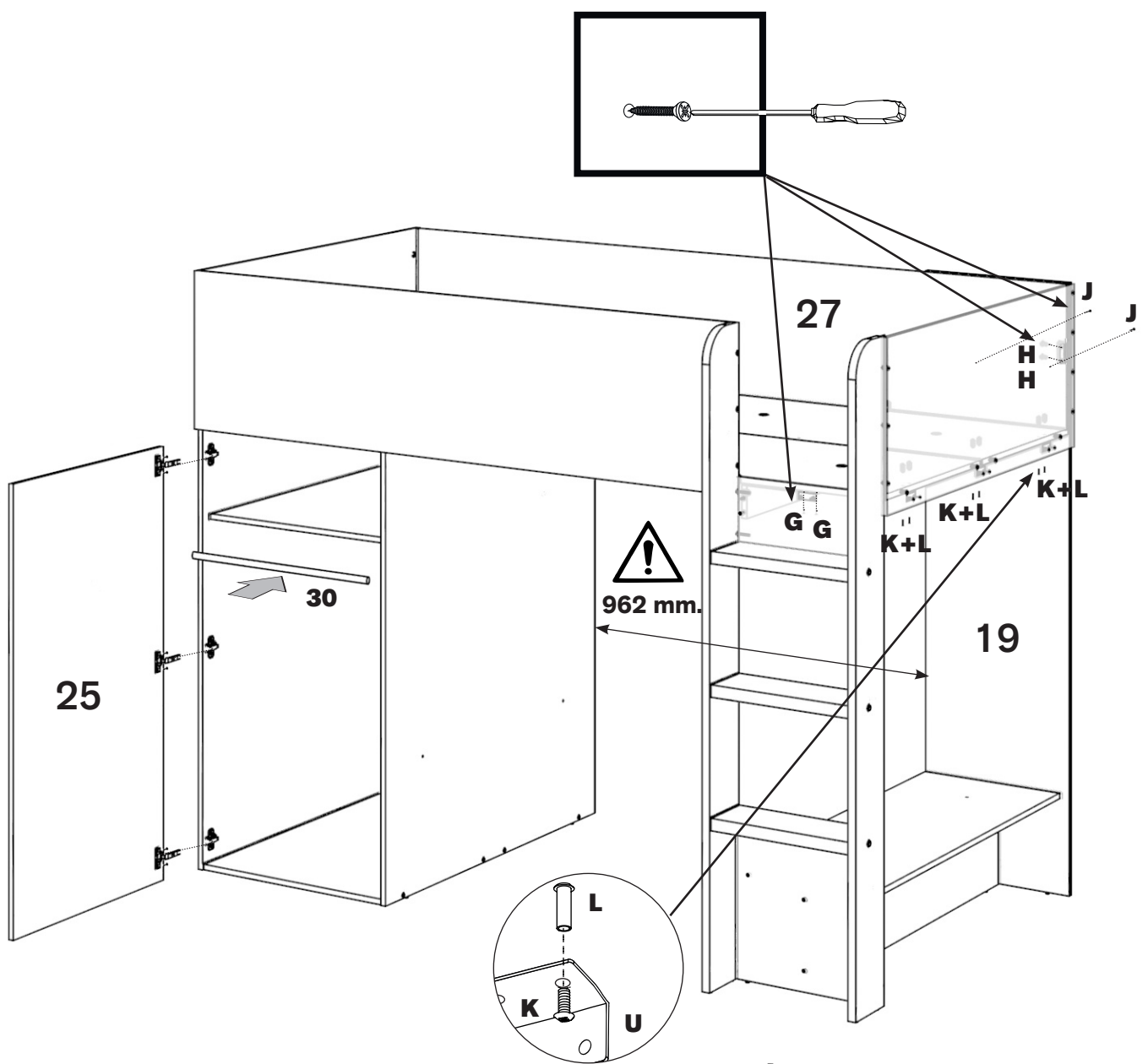

**EN** Before to tighten the screw "aa", you have to slacken a little the screw "bb"

**ES** Antes de apretar el tornillo "aa", hay que aflojar un poco el tornillo "bb"

**FR** Avant de presser le vis "aa", il y a que relâcher un peu le vis "bb"

**PT** Antes de apertar o parafuso "aa", deve desapertar um pouco o parafuso "bb"

**NL** Voordat de schroef "aa" wordt vastgedraaid, moet de schroef "bb" enigszins worden losgedraaid

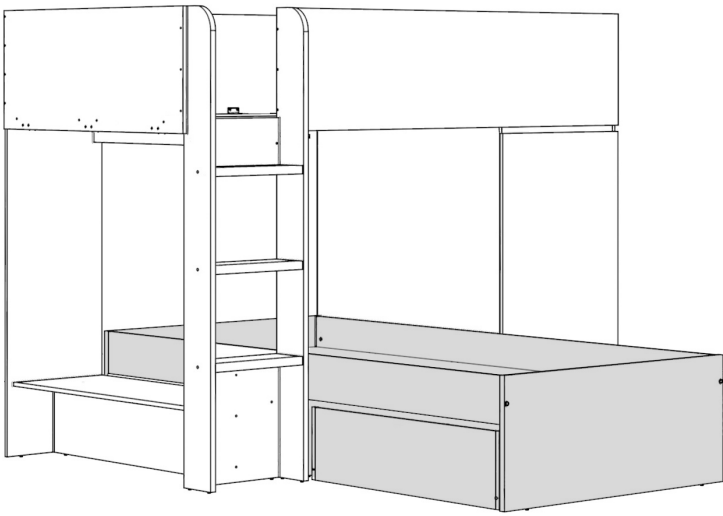

**DE** Bevor die Schraube "aa" festgezogen wird lösen Sie ein wenig die schraub "bb"

# Option A



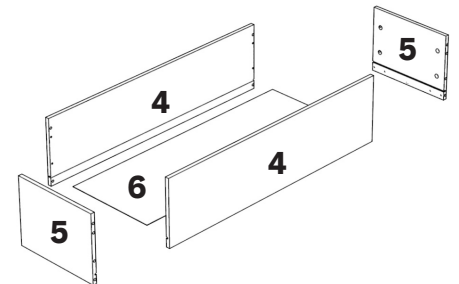
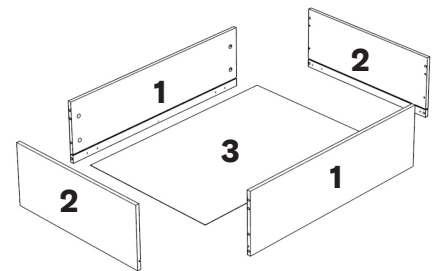
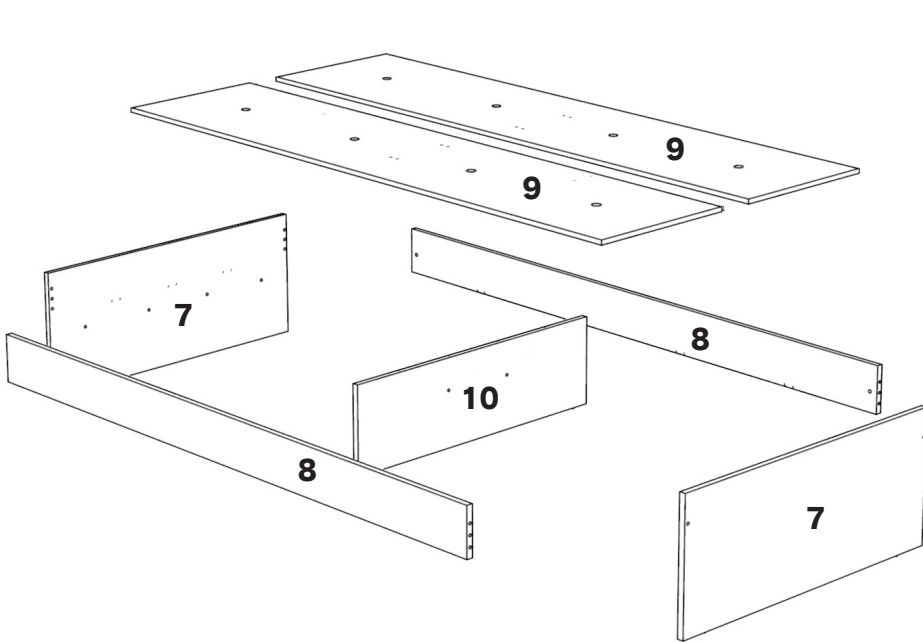
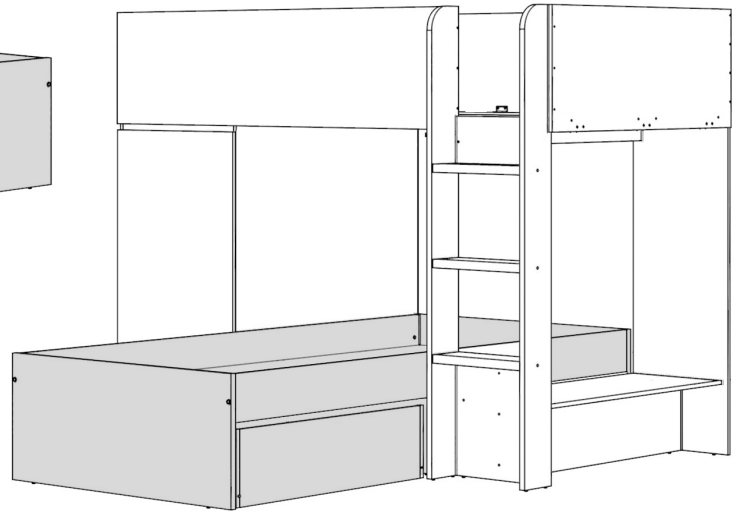

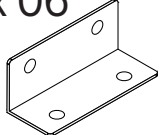
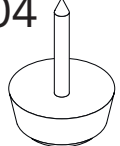

# Option B

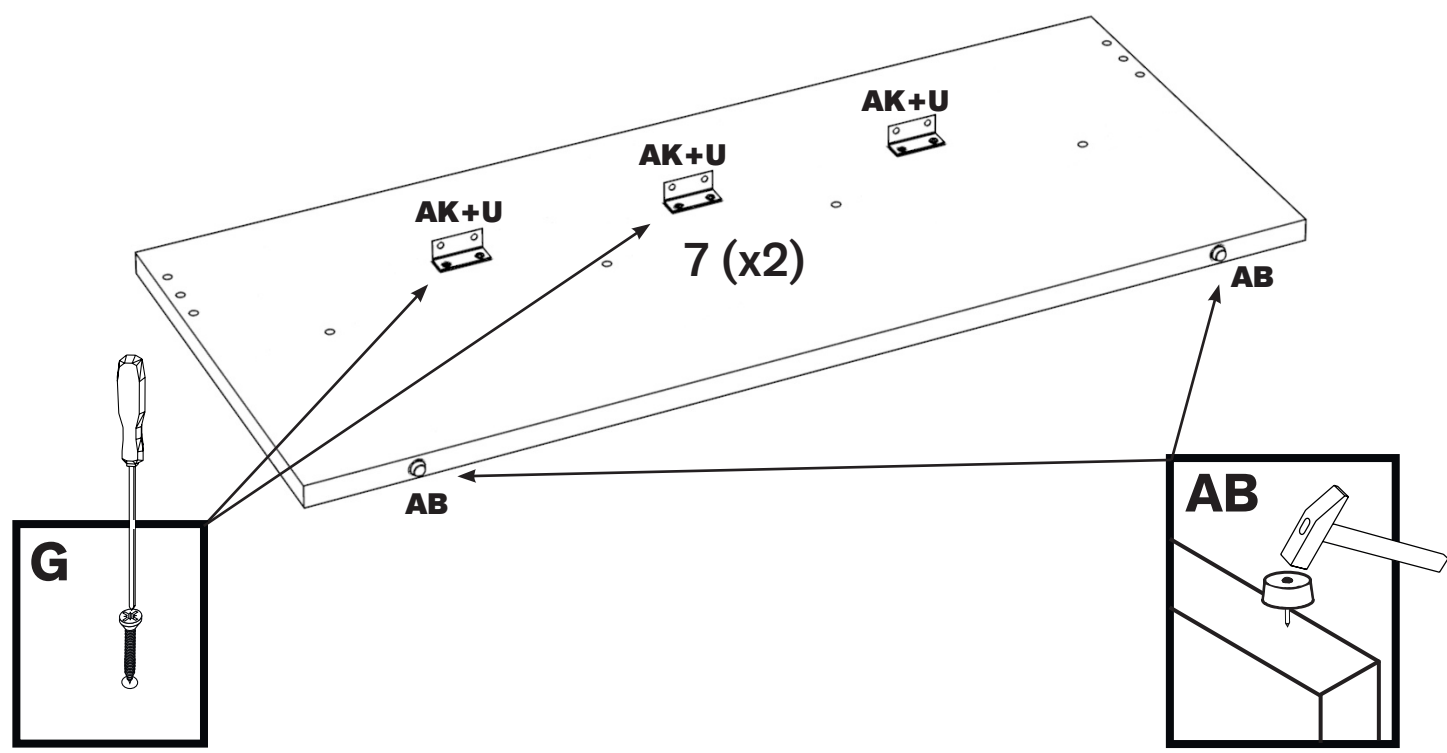

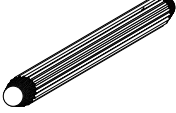
26	<b>AK x 12</b>   4 x 20 mm.	<b>U x 06</b> 	<b>AB x 04</b> 
----	--	--	---

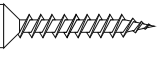

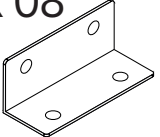
27	<b>C x 08</b> 	<b>AK x 16</b>   4 x 20 mm.	<b>O x 04</b>  13 mm.	<b>U x 08</b> 
----	--	--	--	--

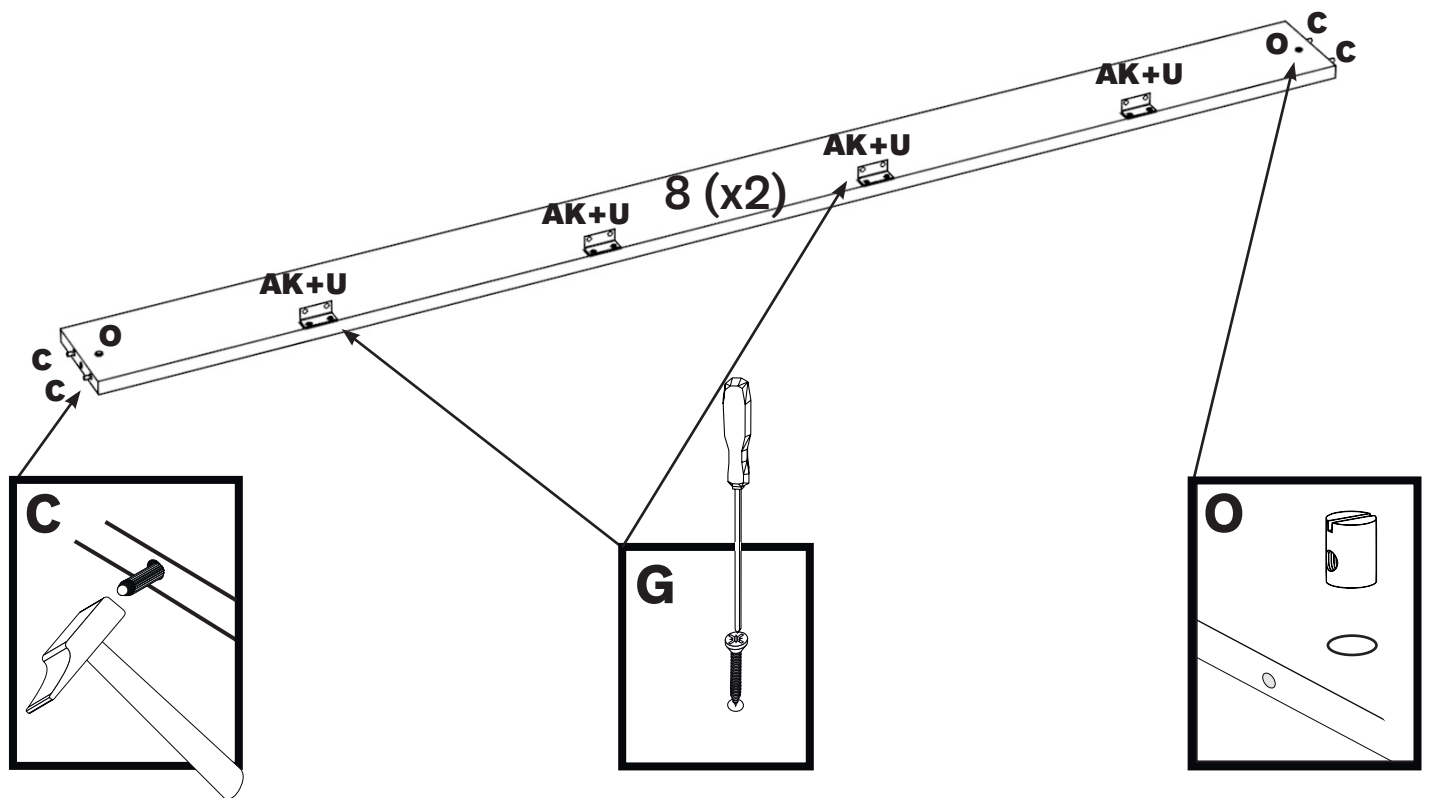

28

H x 08



4 x 16 mm.

W x 02

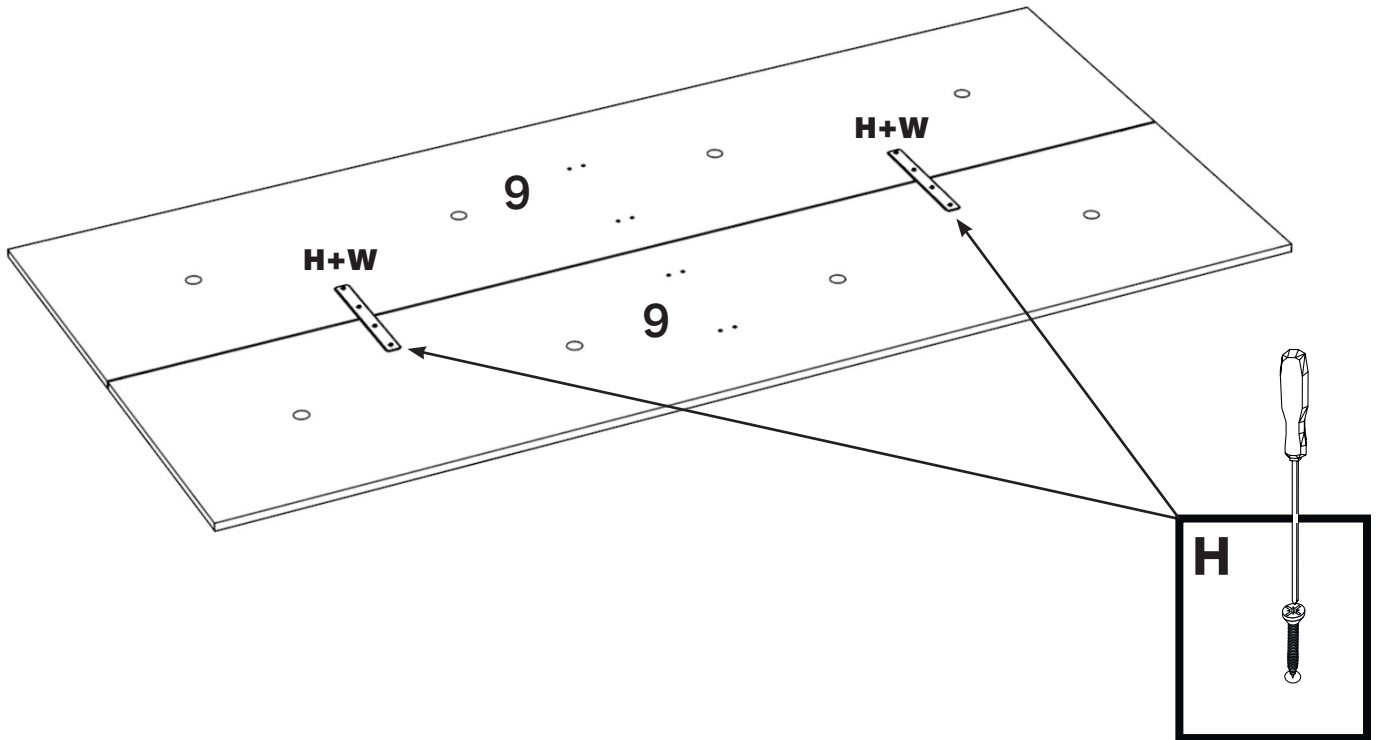
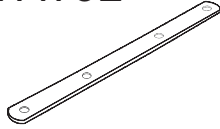

29

AB x 02

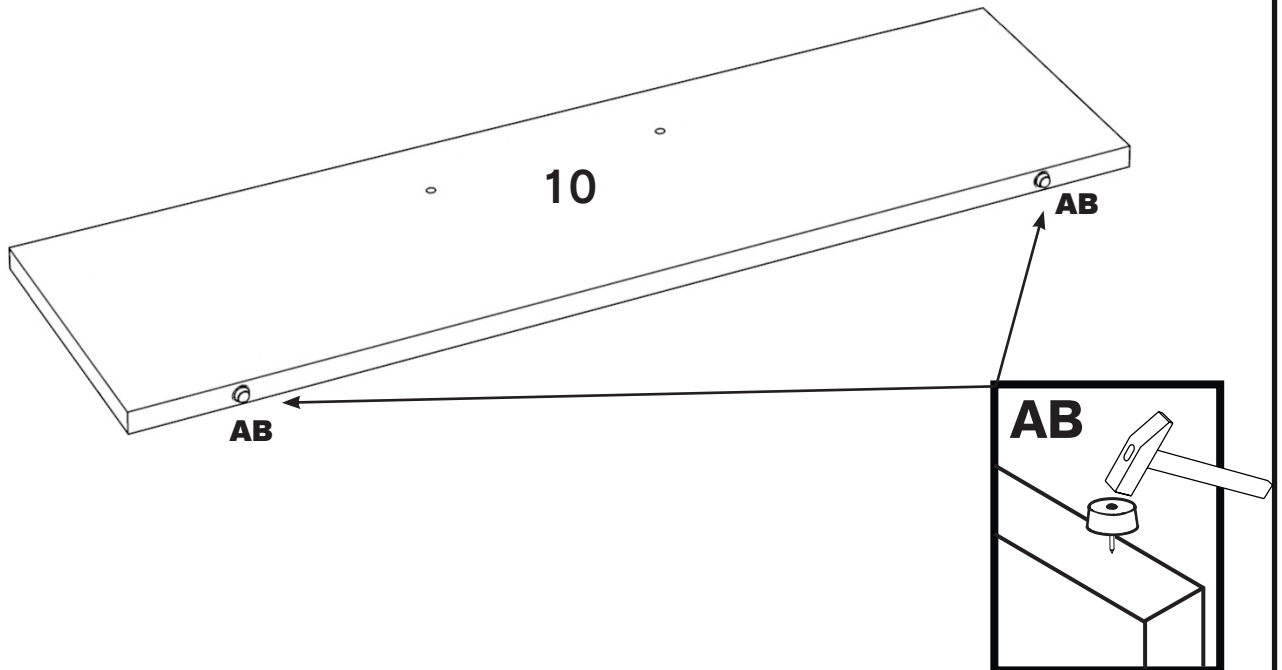
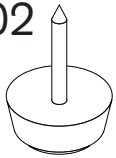

**30** Ñ x 04  
M6 x 60 mm.

AE x 01  
Nº 4

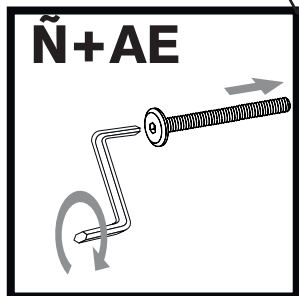
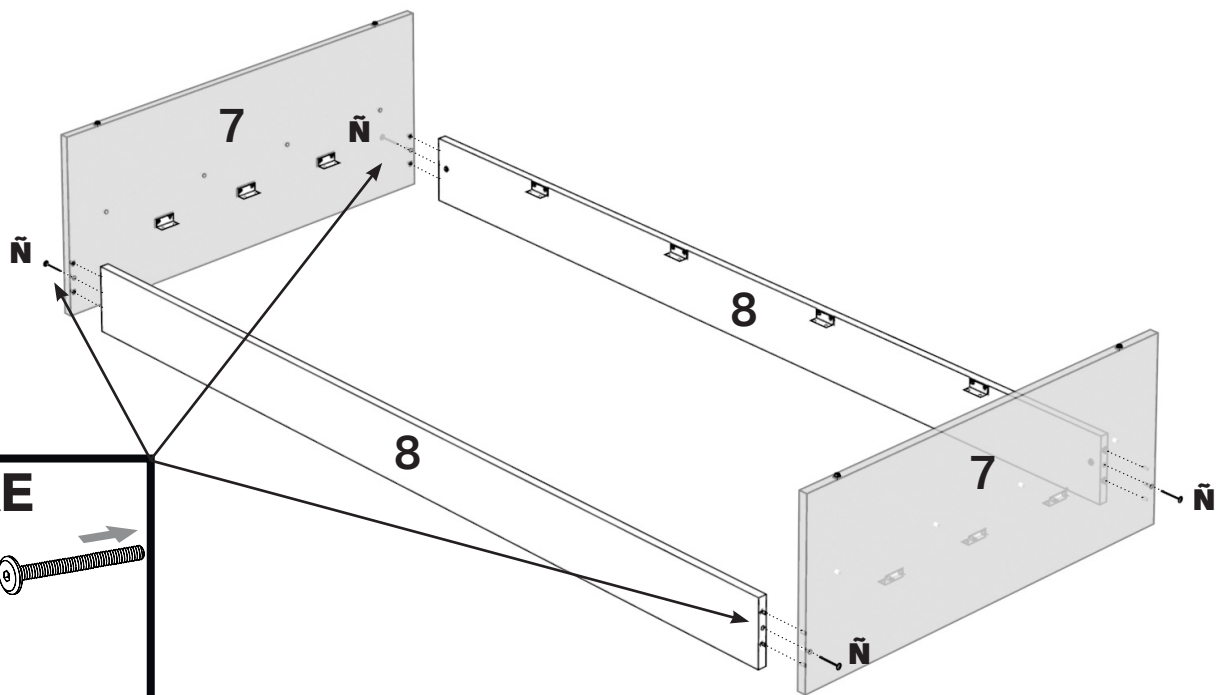

**31** N x 04  
5 x 50 mm.

AD x 01  
Nº 3

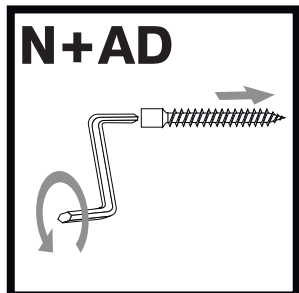
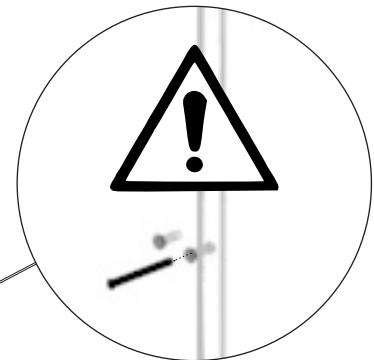
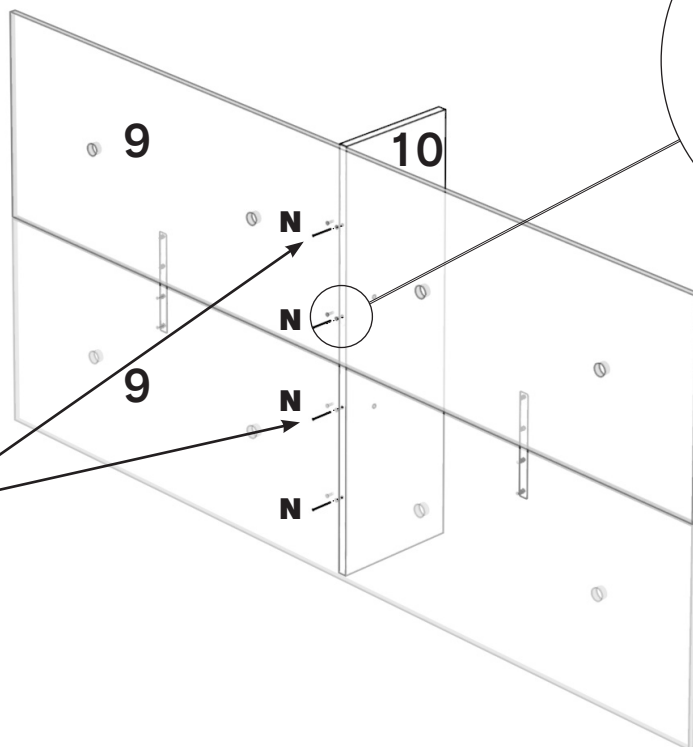

32

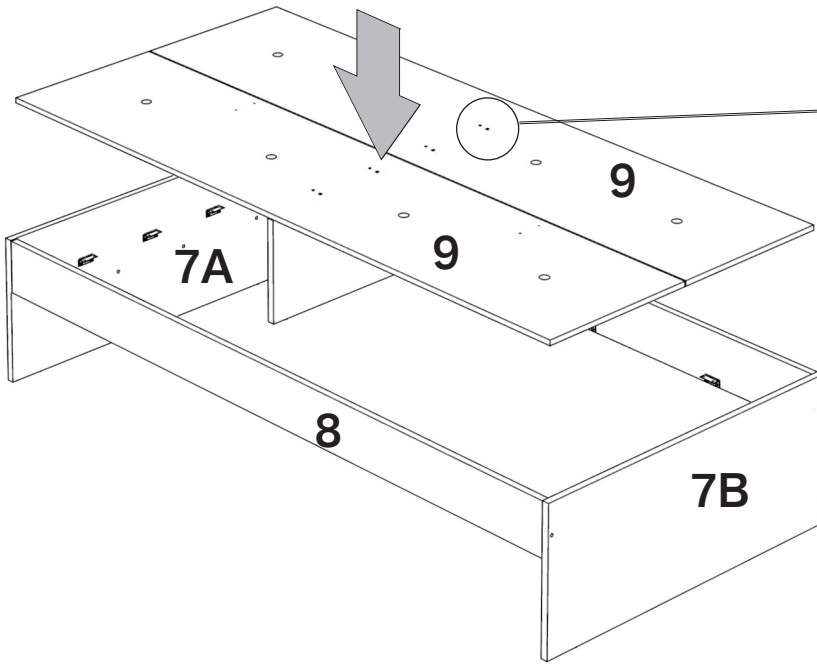

33

E x 08

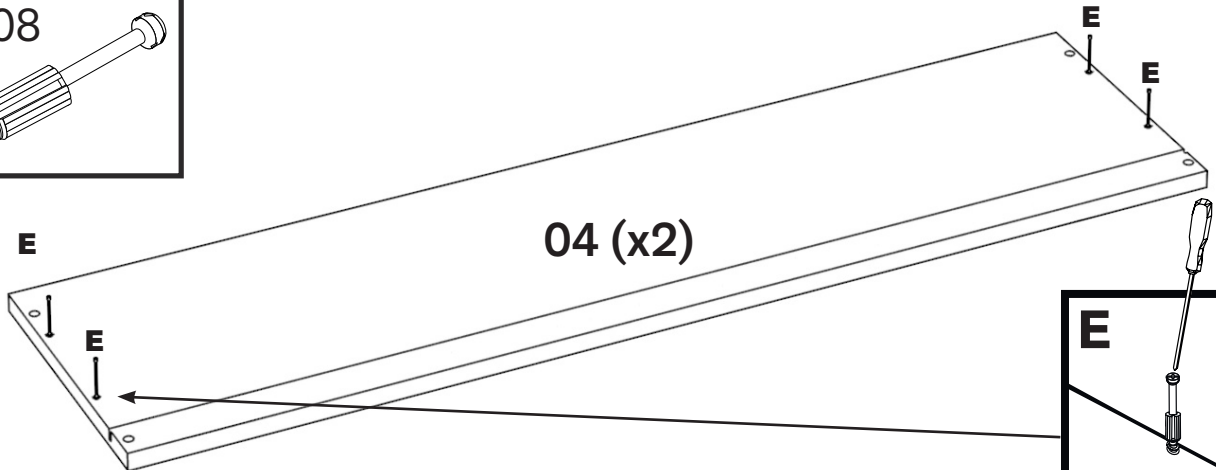
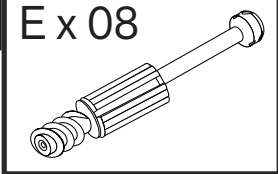

34

C x 08

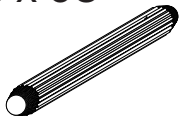

F x 08

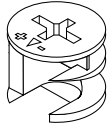



G x 08



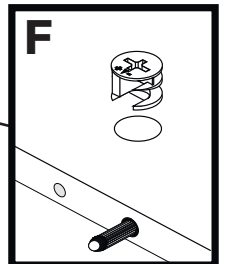
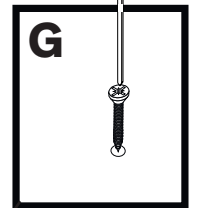
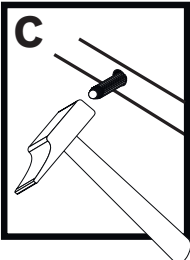
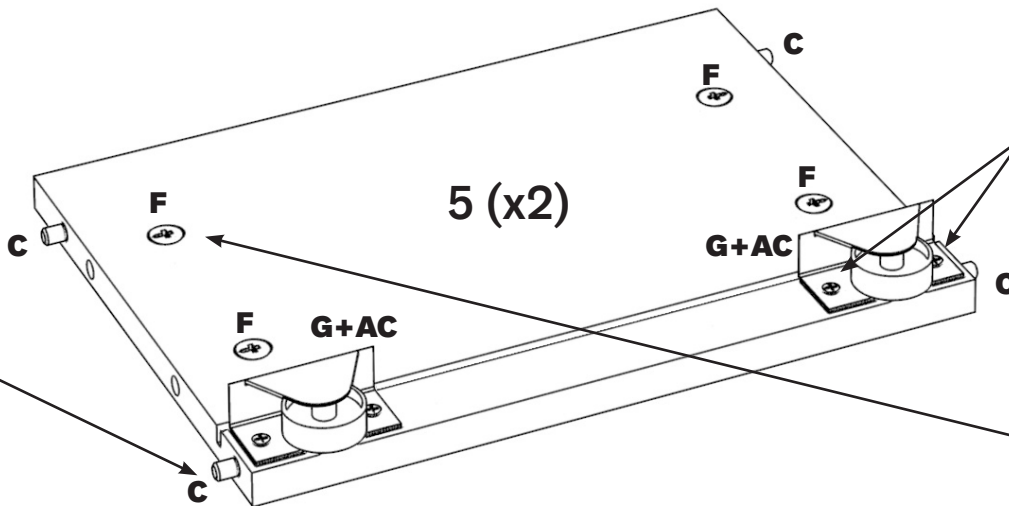
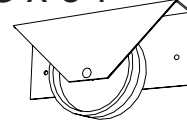

3.5 x 15 mm.

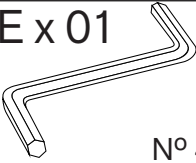
AC x 04

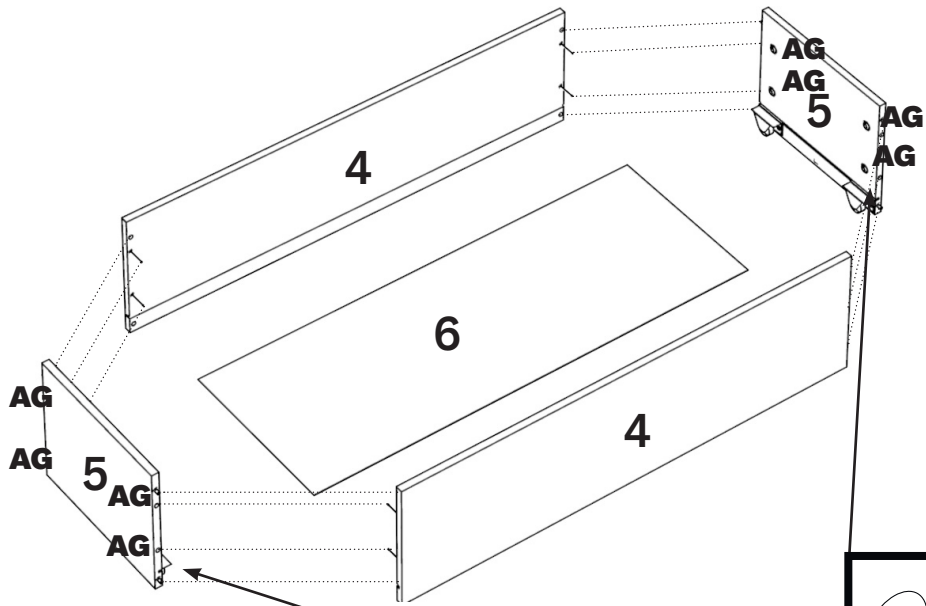
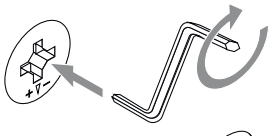

**35** AE x 01  N° 4  
 AG x 08  17 mm.

**AE+AG** 

**36** AI x 04   
 AJ x 04  3.5 x 20 mm.

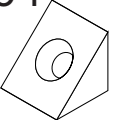
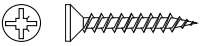
**AI+AJ**

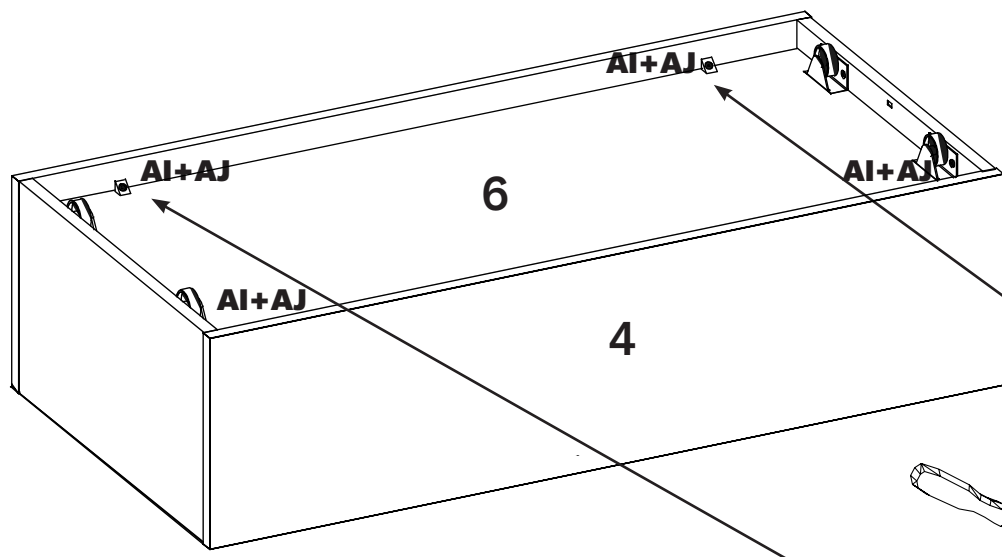
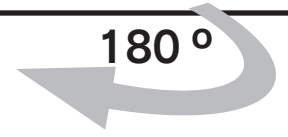
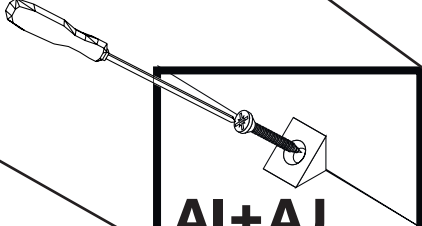
37

C x 08

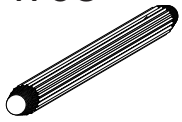

F x 08

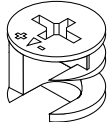

1 (x2)

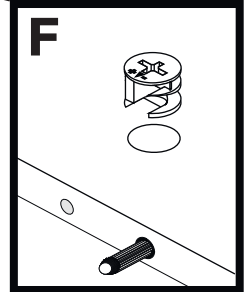
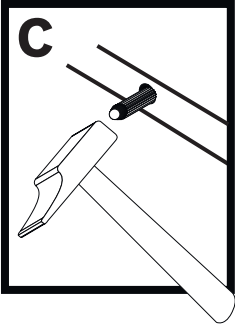
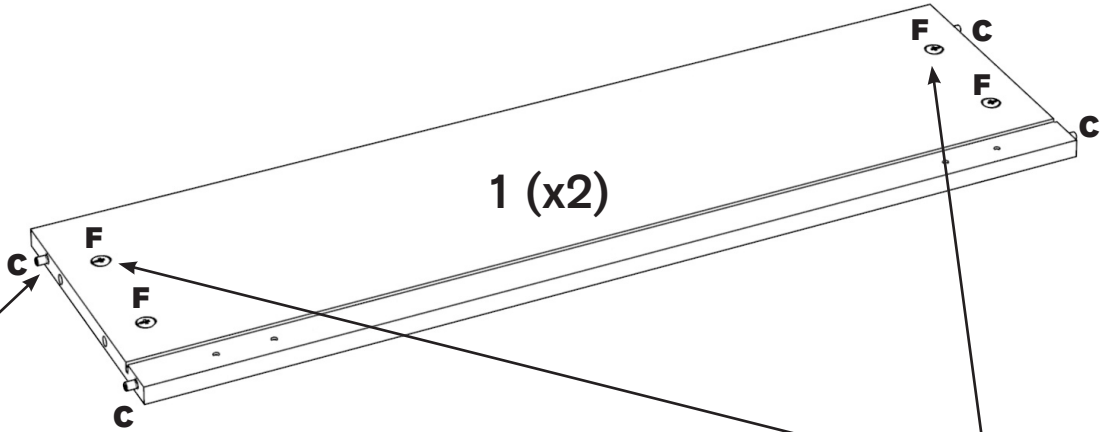

38

E x 08

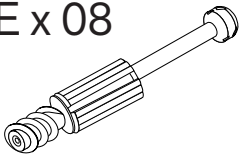

G x 08

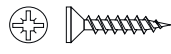

3.5 x 15 mm.

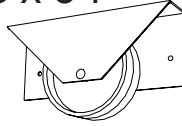

AC x 04

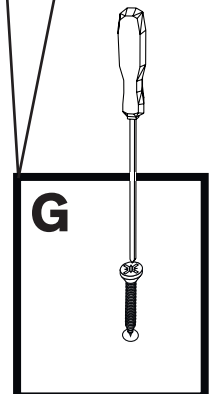
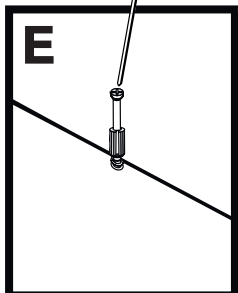
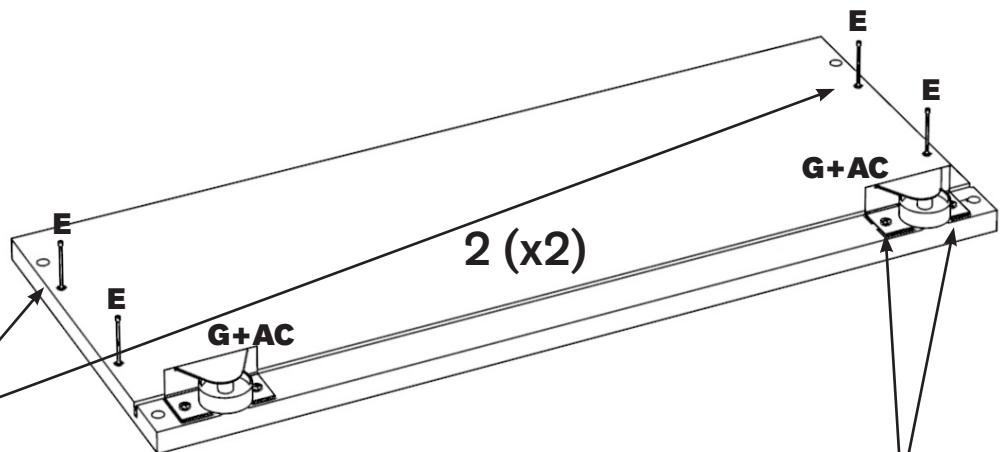

2 (x2)



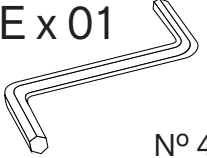

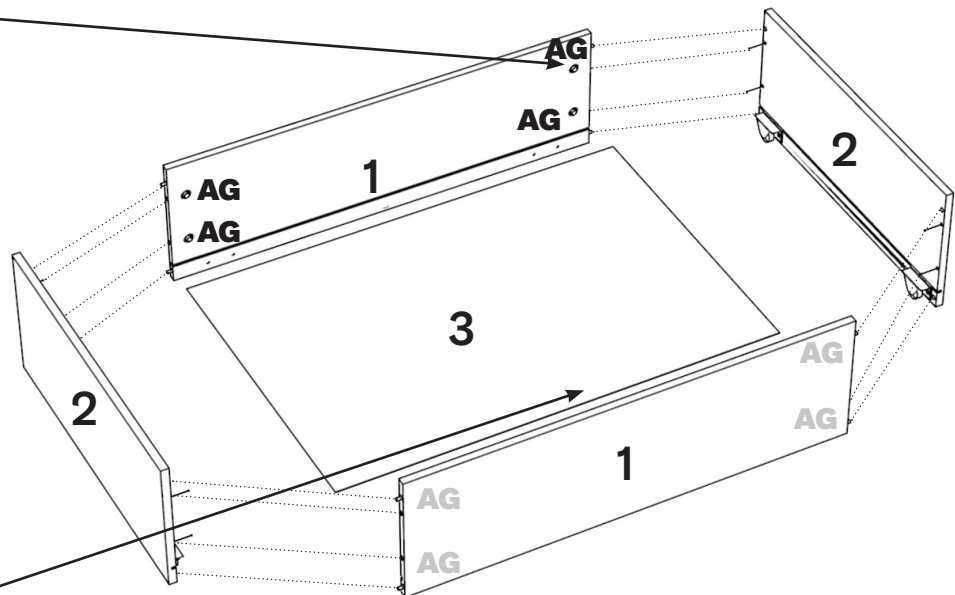
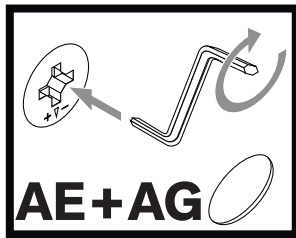

**39** AE x 01  
 N° 4  
 AG x 08  
 17 mm.

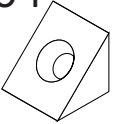
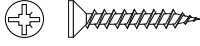

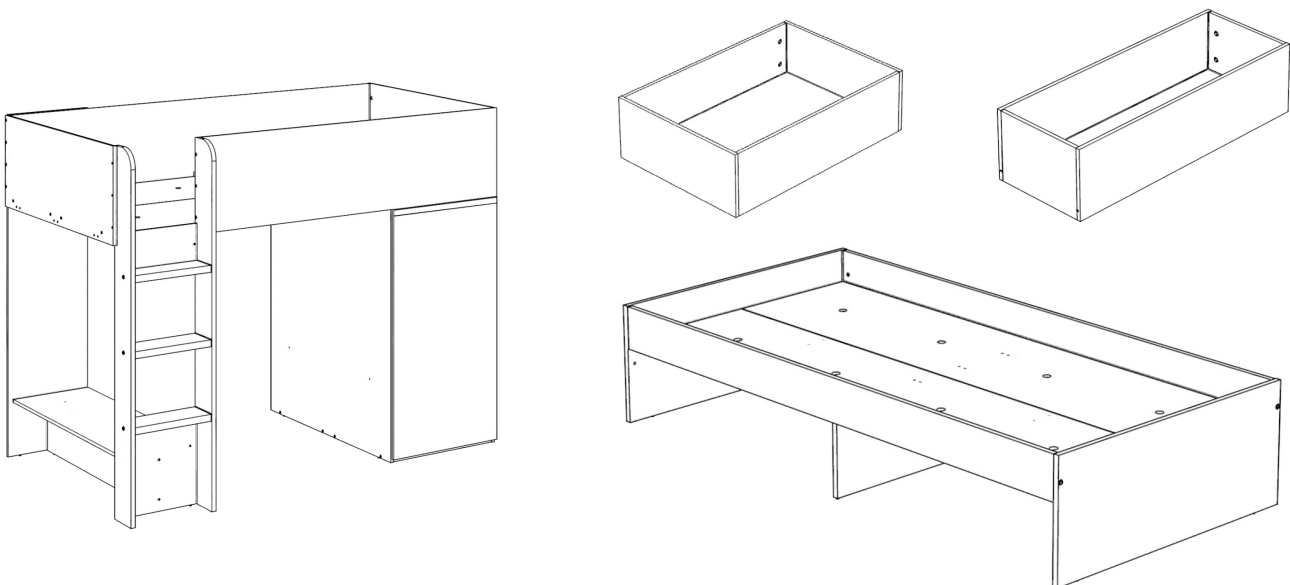
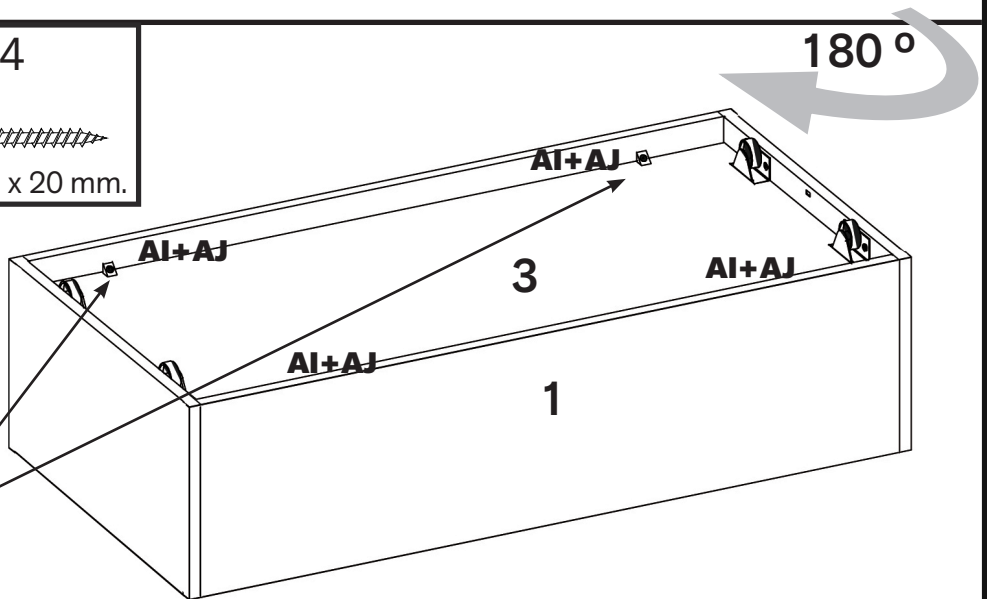
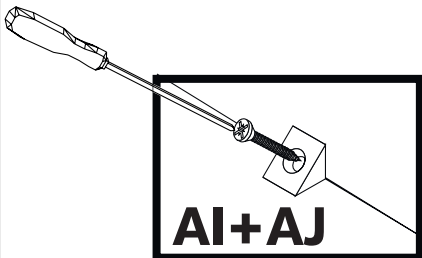
**40** AI x 04  
  
 AJ x 04  
 3.5 x 20 mm.

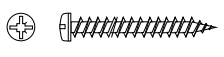

<b>41</b> J x 02  4 x 30 mm.	AG x 08  17 mm.
---	--

# Option A

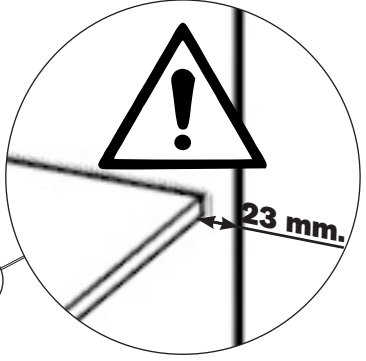
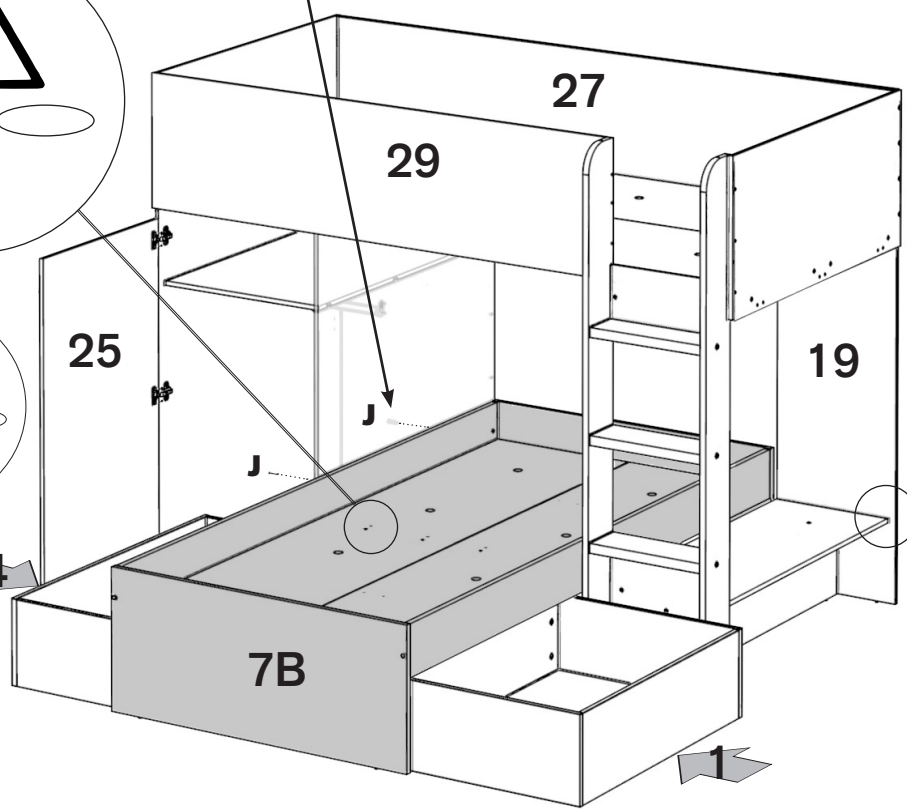
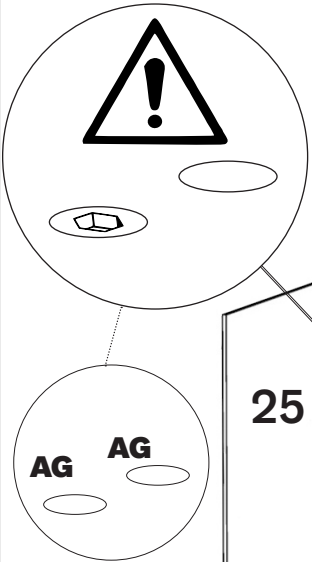
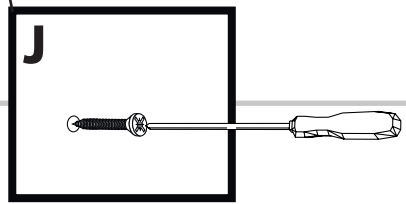
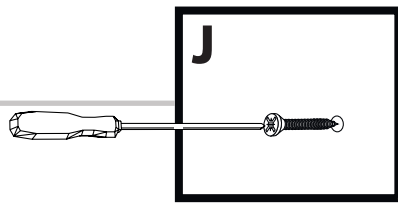
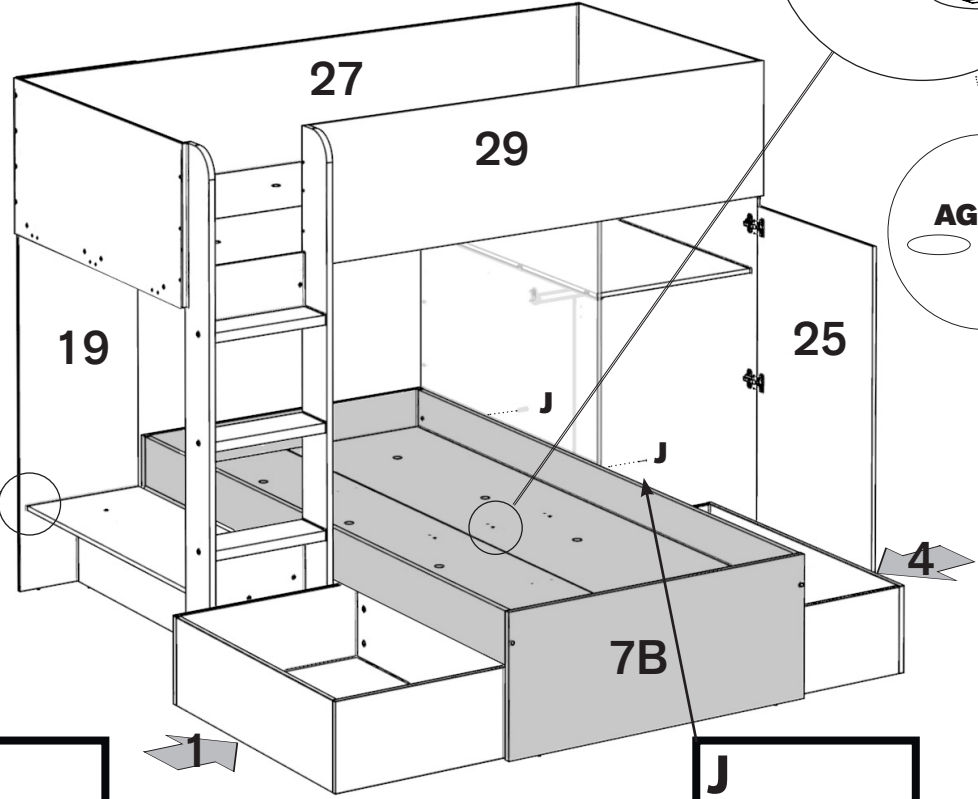

# Option B

# Option C, D

PAG. 35-64

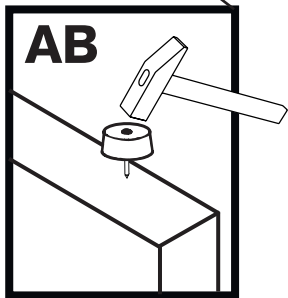
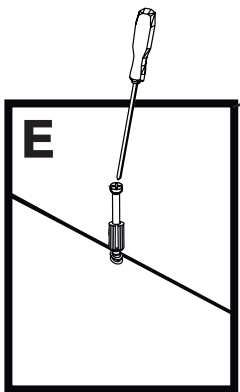
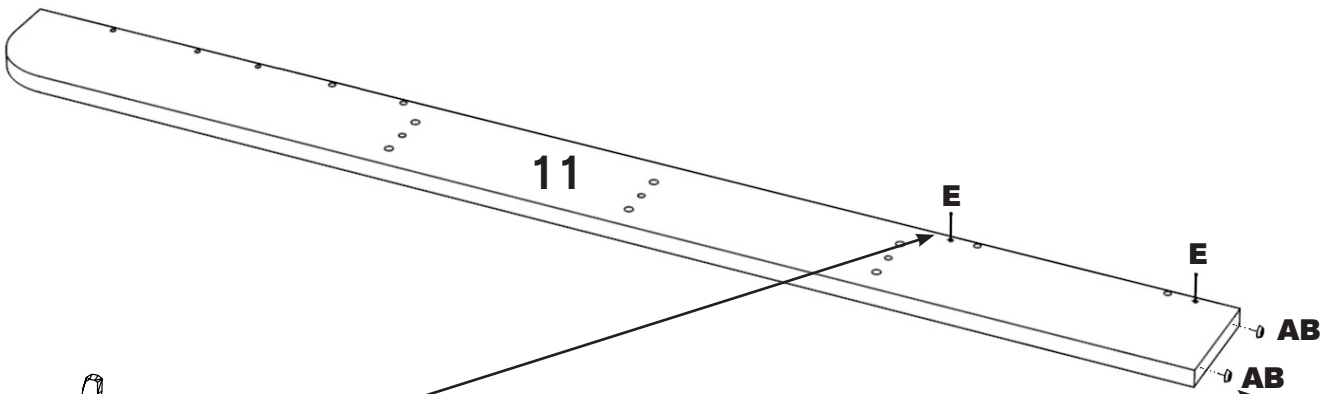
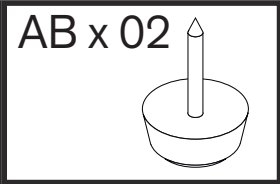
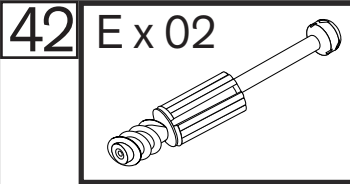
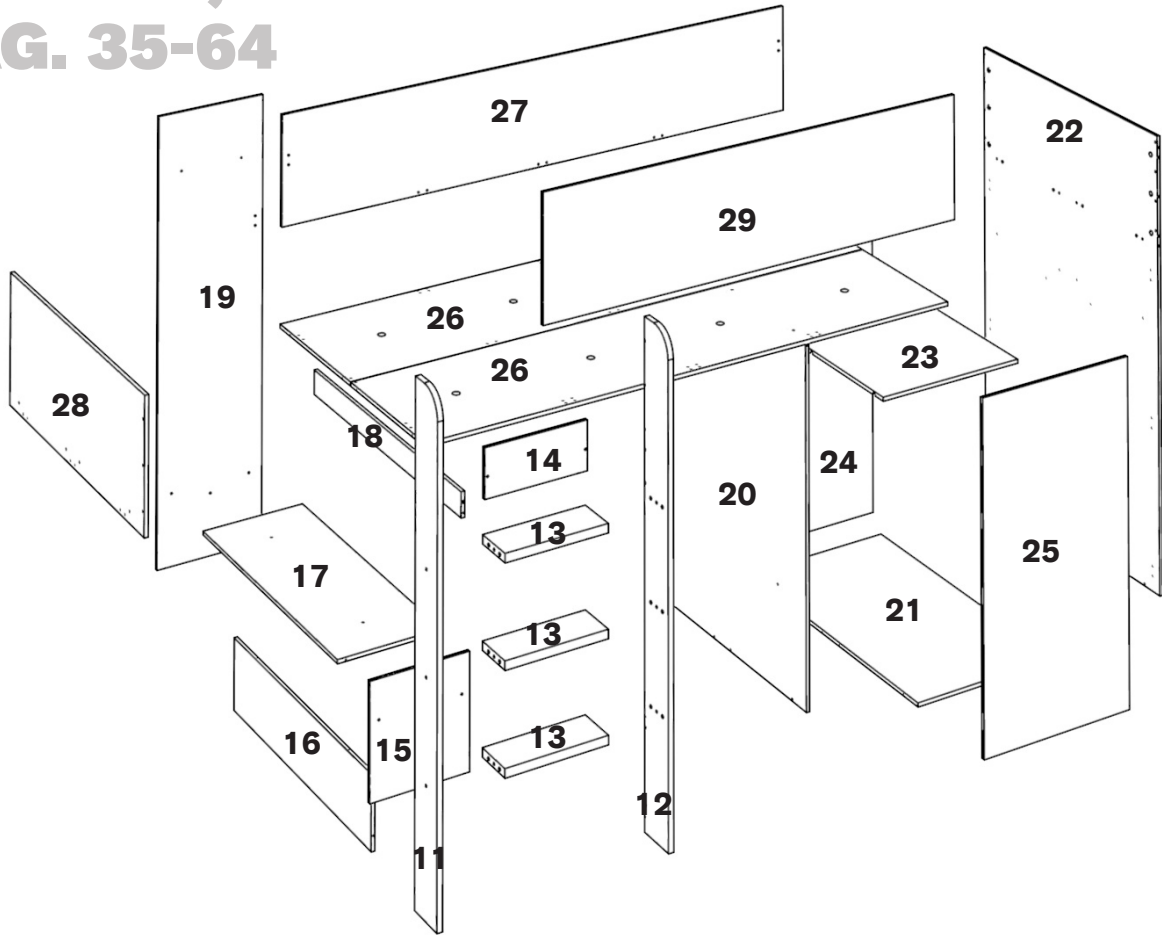

**43** E x 02      AB x 02

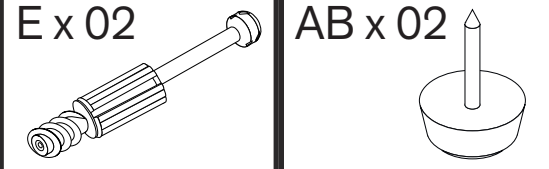
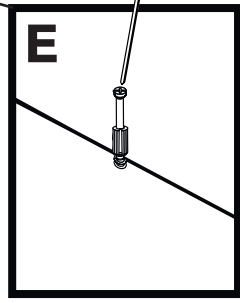
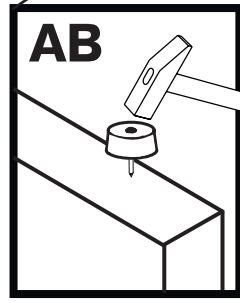
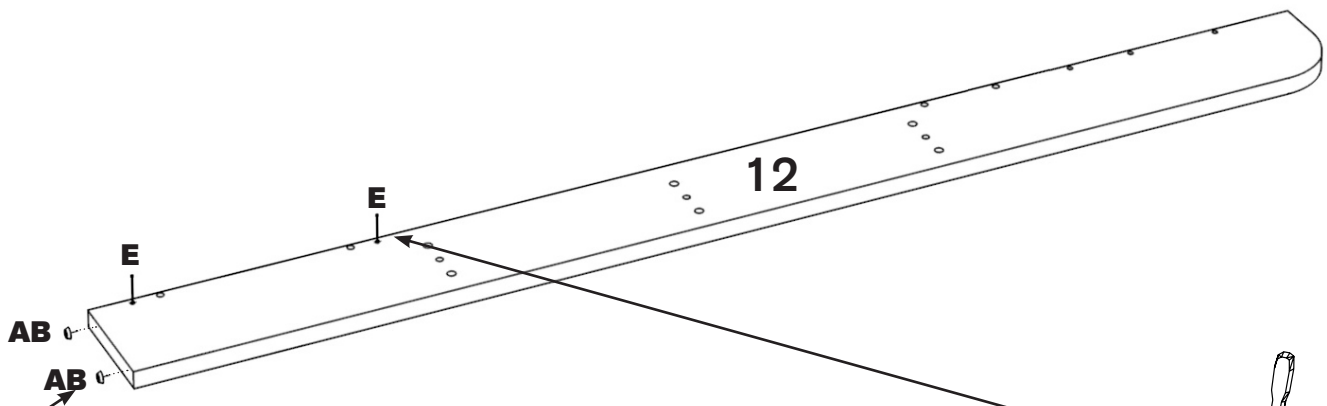
**44** D x 12      P x 06

10 x 70 mm.      21 mm.

45

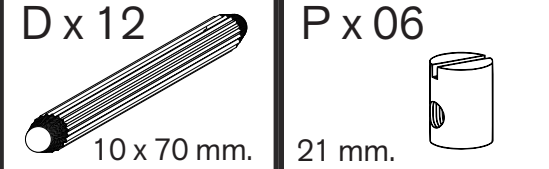
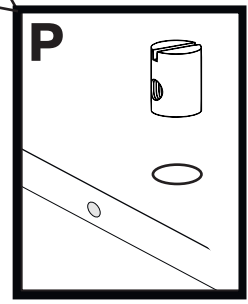
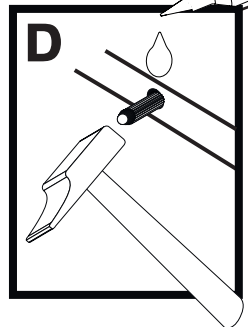
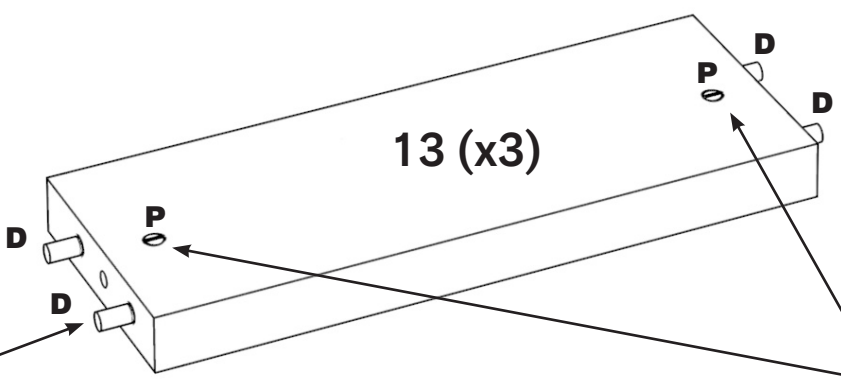
C x 04

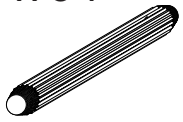

G x 02



3.5 x 15 mm.

U x 01

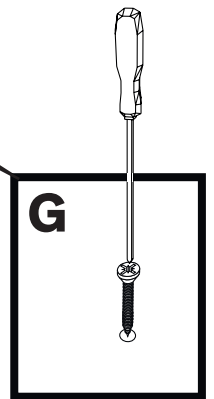
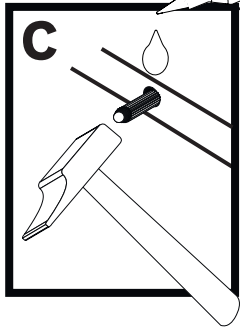
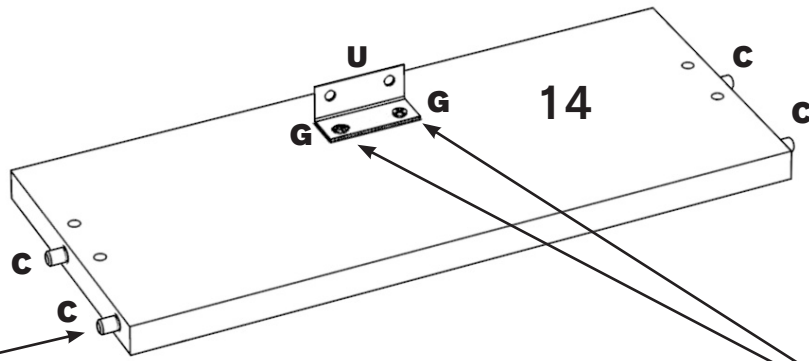
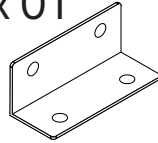

46

C x 04

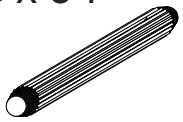

F x 04

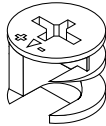

AB x 02

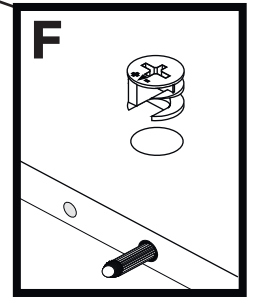
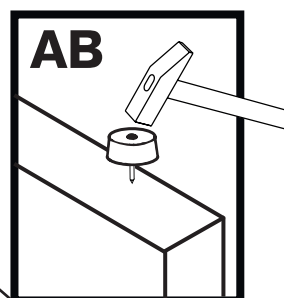
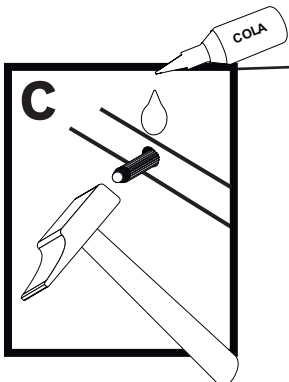
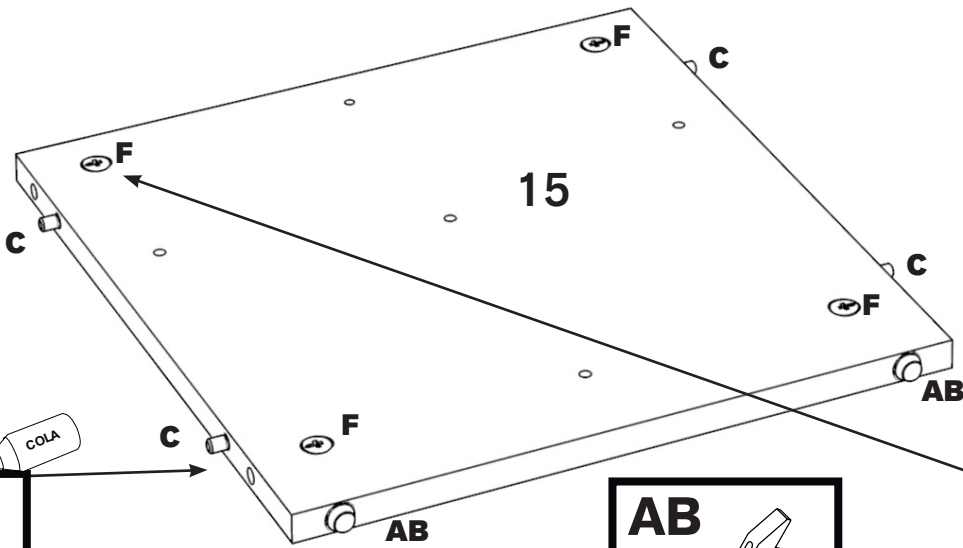

**47** Ñ x 06  
M6 x 60 mm.

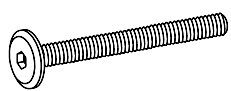

**AE** x 01  
Nº 4

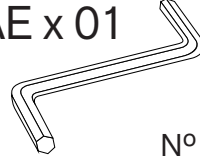

**AG** x 04  
17 mm.

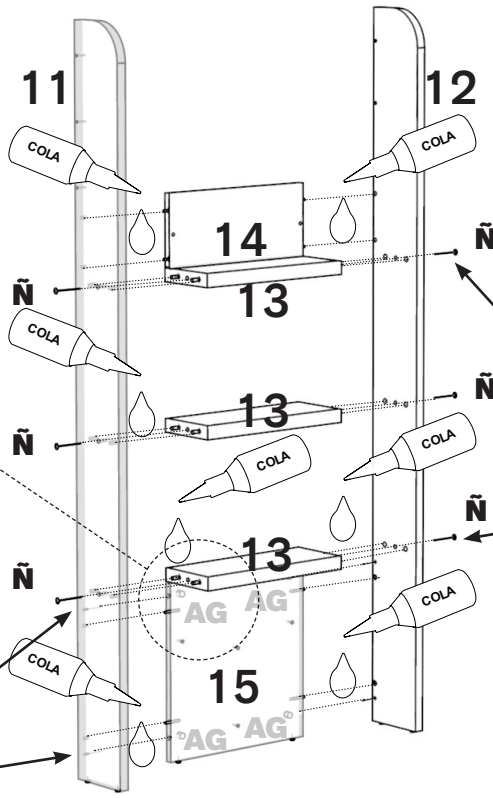
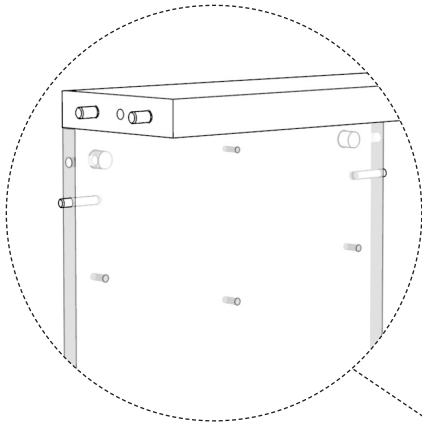
**AE**

**Ñ+AE**

**Option C**

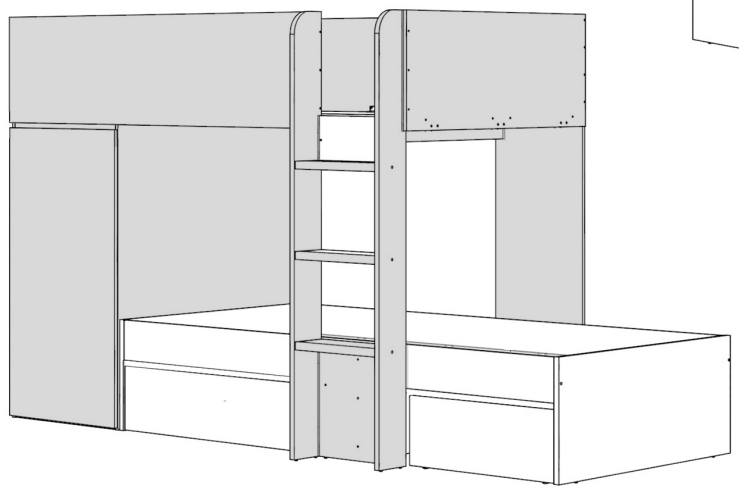
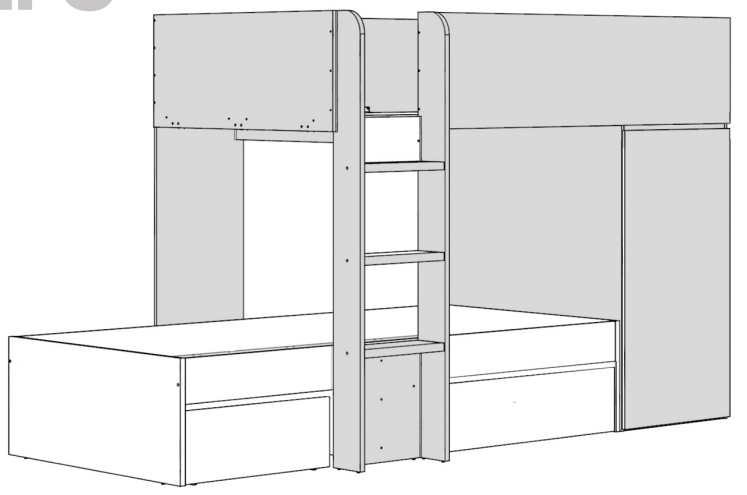

**Option D**

48 AB x 02

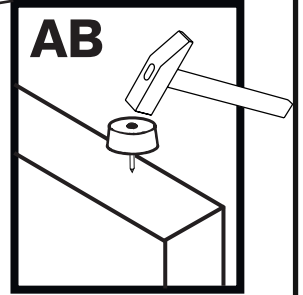
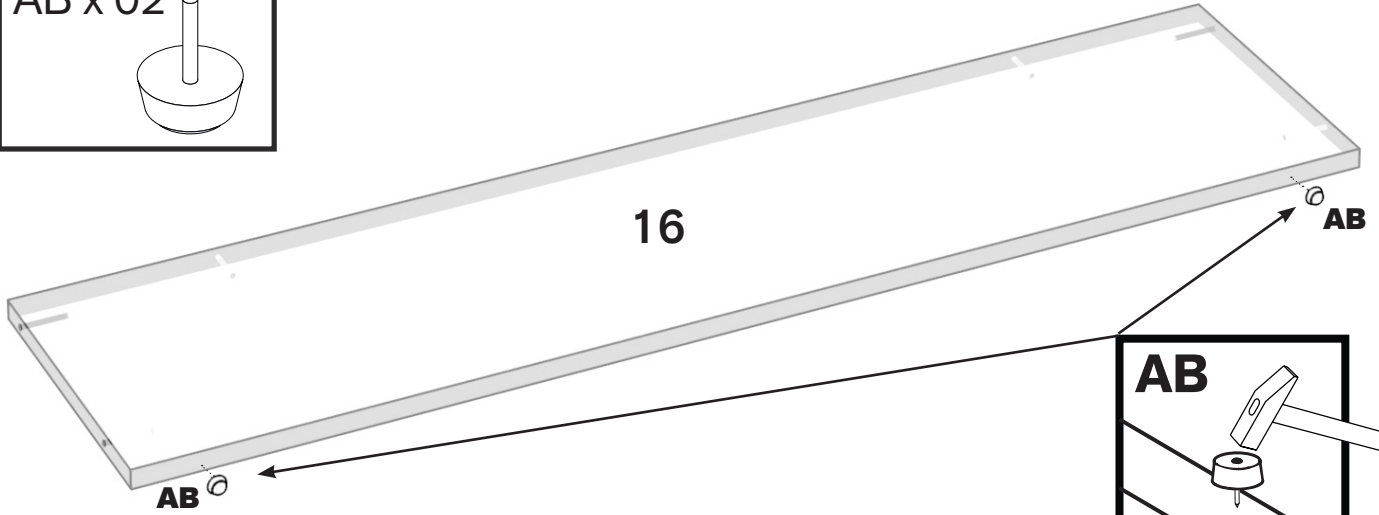
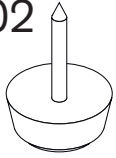

49 C x 01

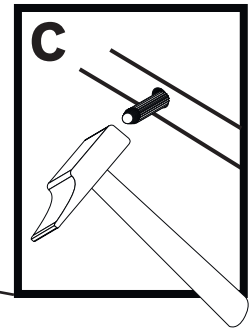
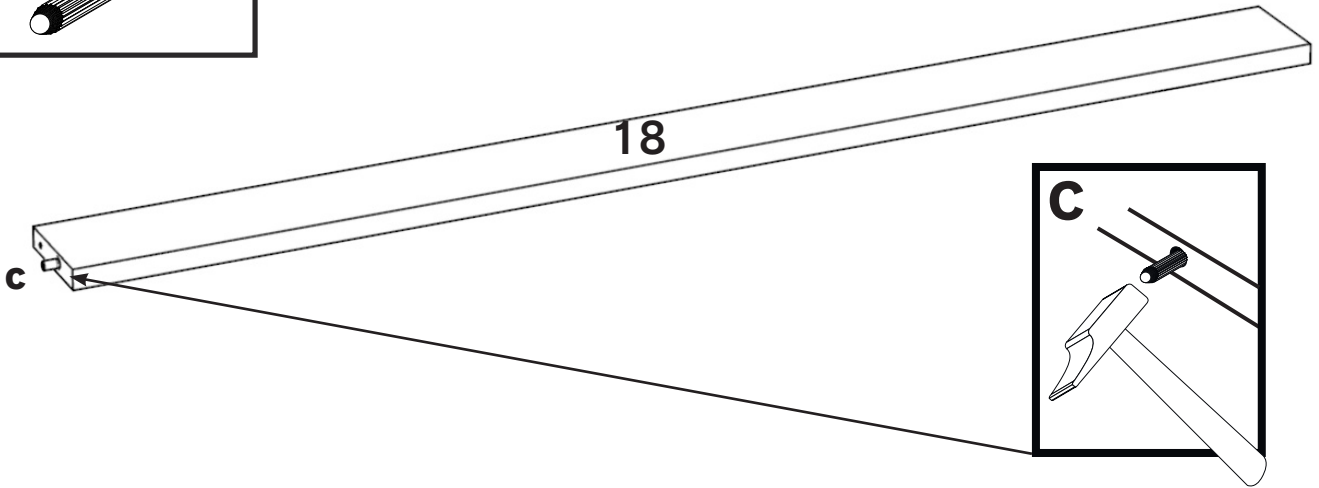
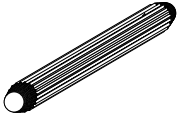

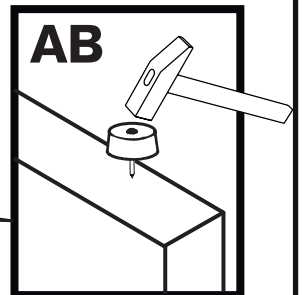
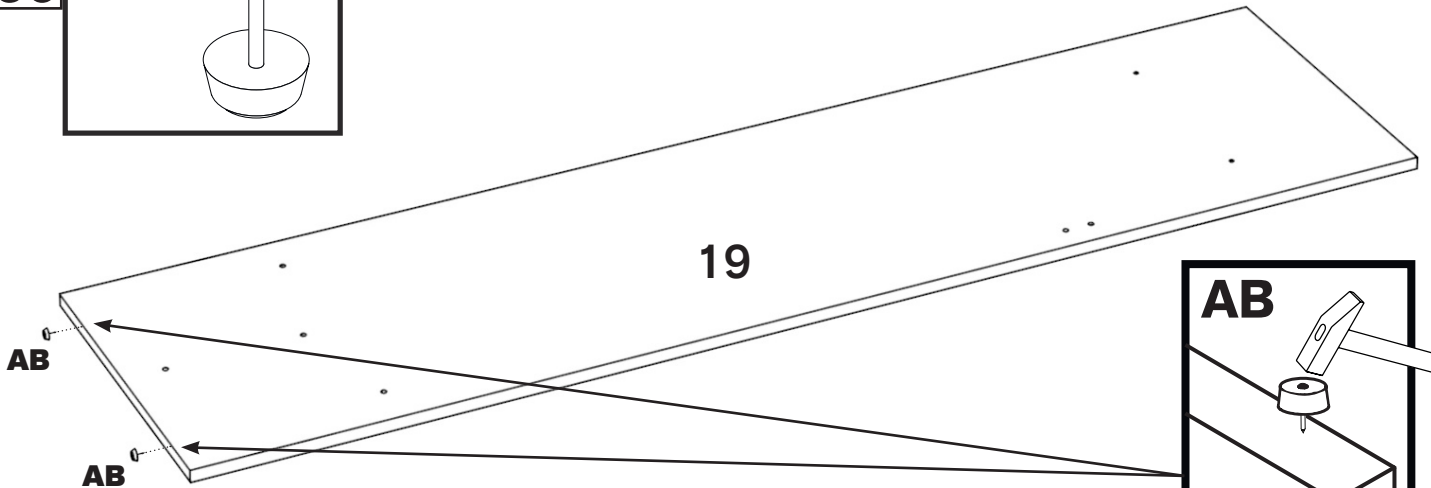
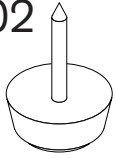

50 AB x 02

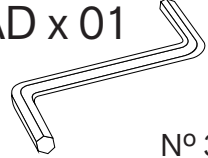

51

N x 13  
  
 5 x 60 mm.

AD x 01  
  
 Nº 3

AG x 08  
  
 17 mm.

# Option C

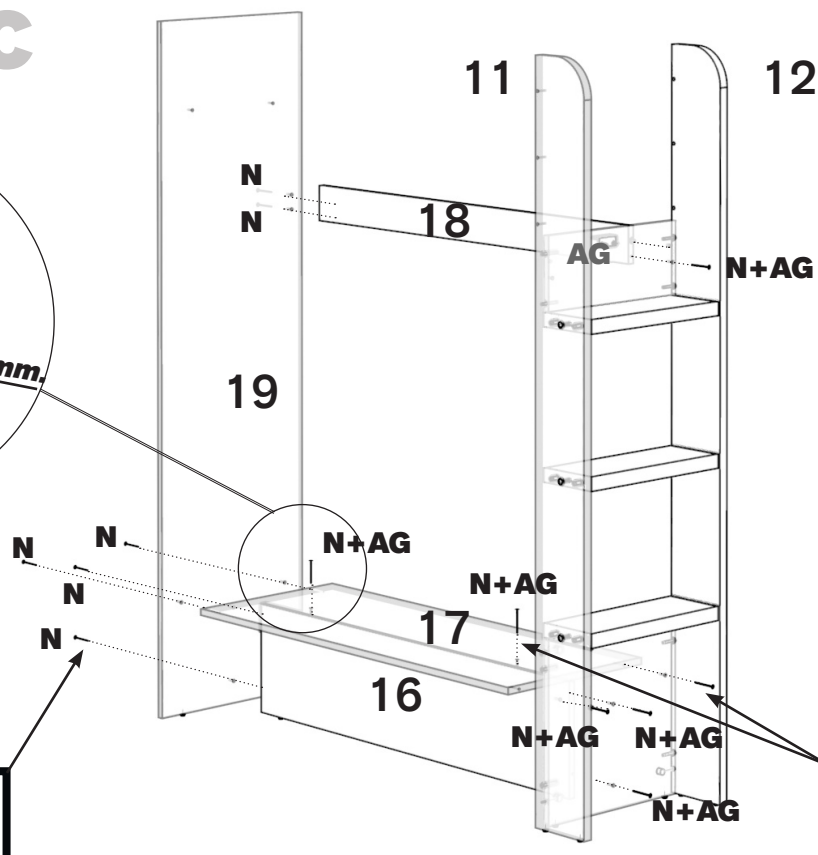
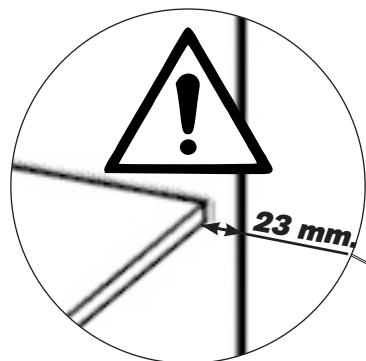

**N+AD**

**N+AD+AG**

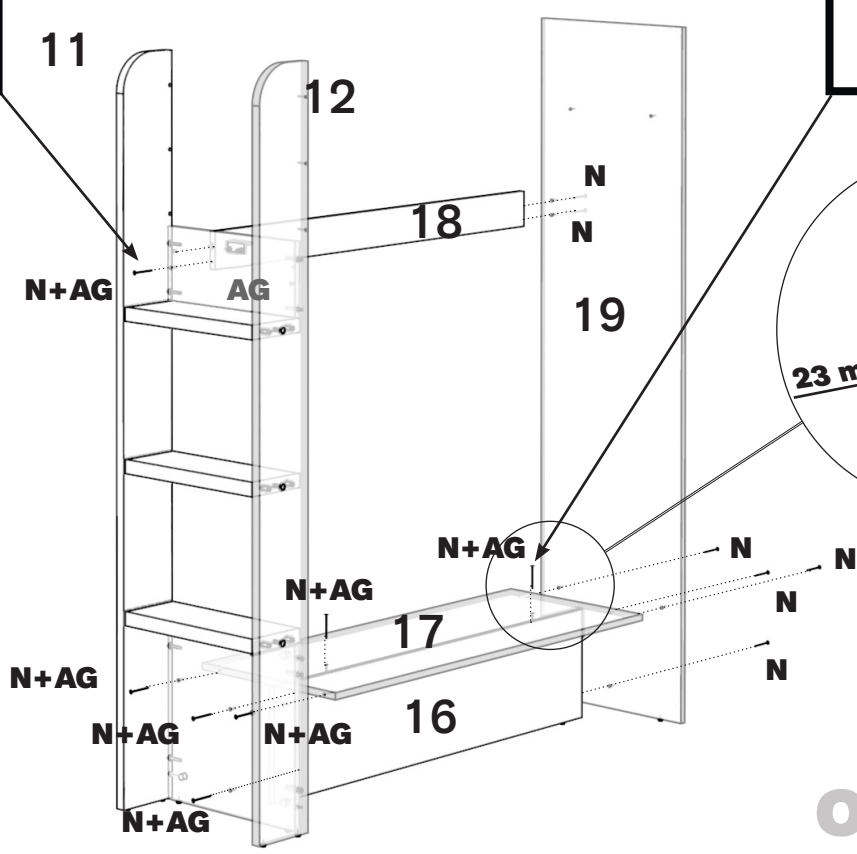

# Option D



52

G x 02



3.5 x 15 mm.

Z x 03



AA x 01

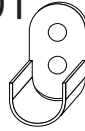

AB x 02



# Option A

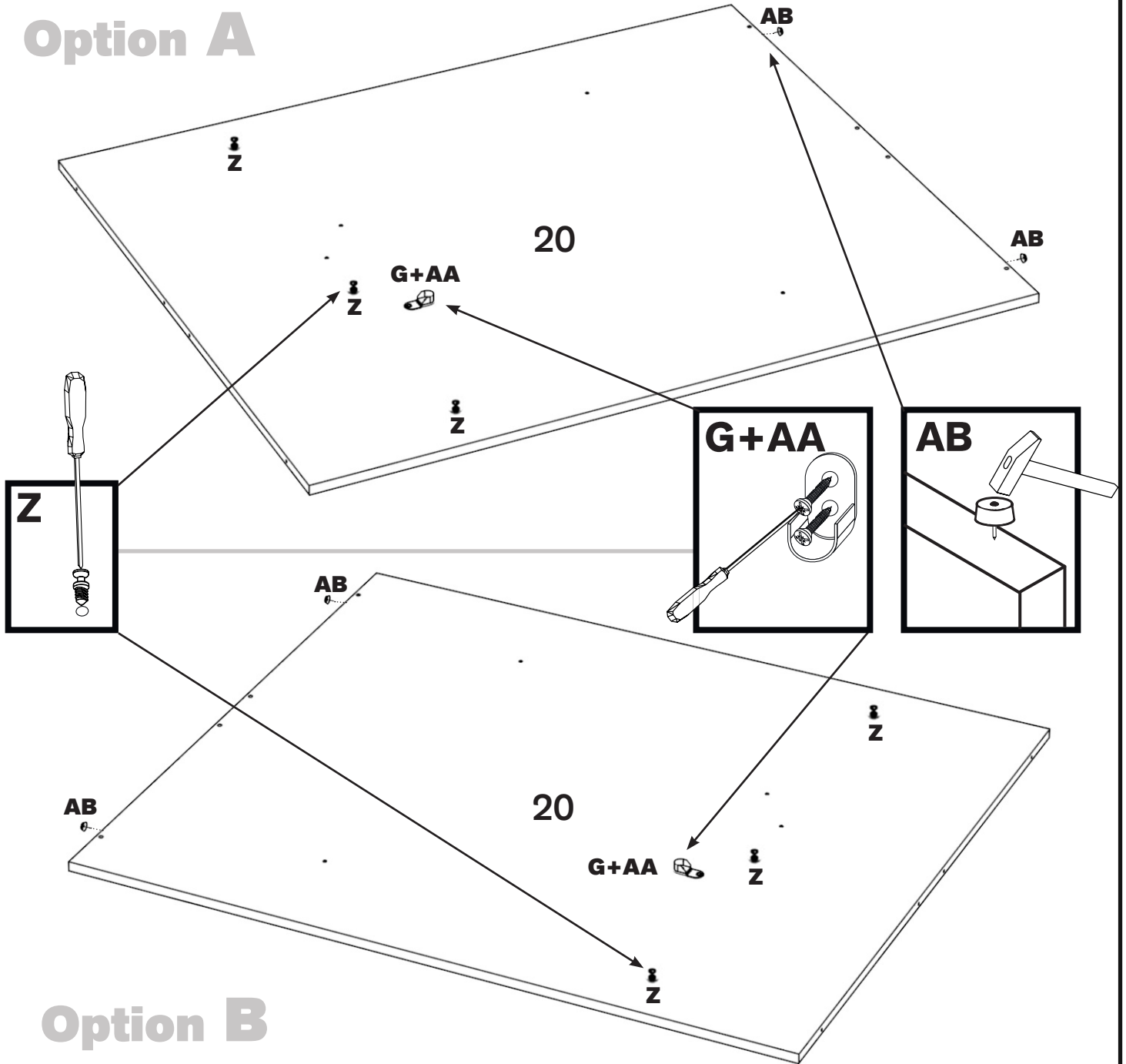



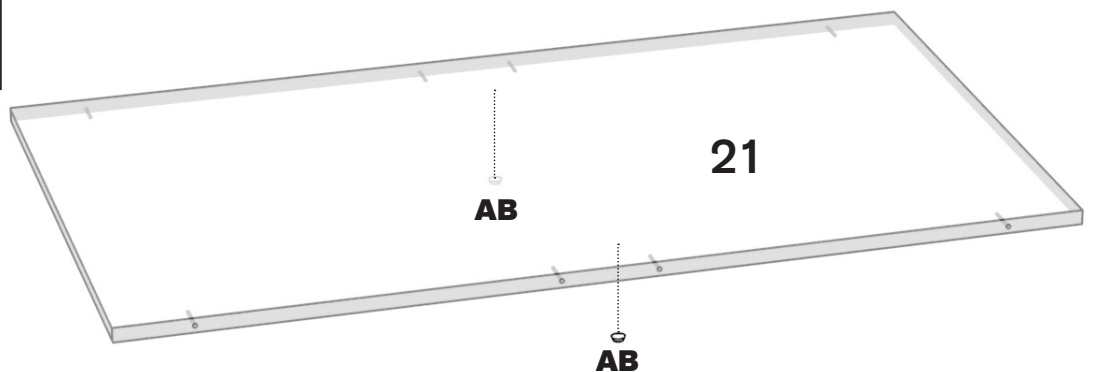
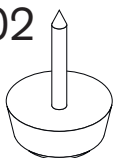

# Option B

53

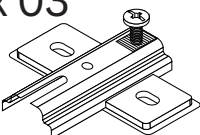
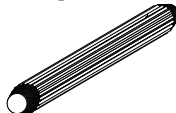
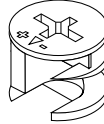
AB x 02

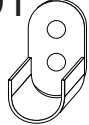
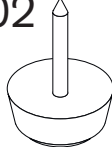

54	B x 03 	C x 02 	F x 03 	G x 08  3.5 x 15 mm.	Z x 03 
	AA x 01 	AB x 02 	AG x 03  17 mm.		

## Option C

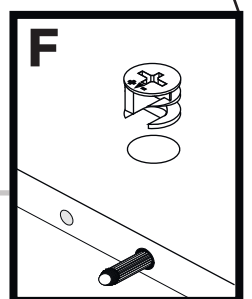
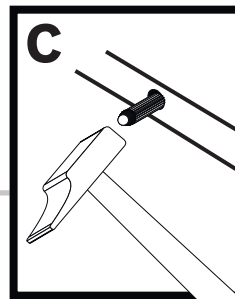
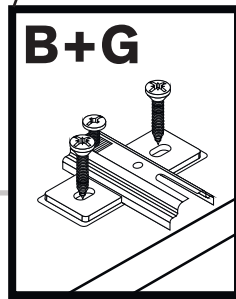
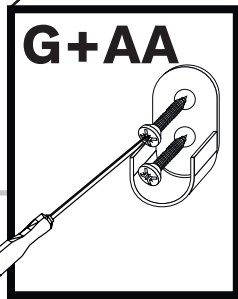
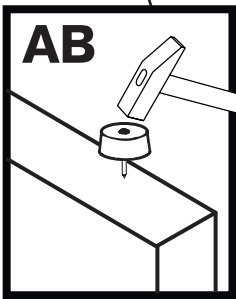
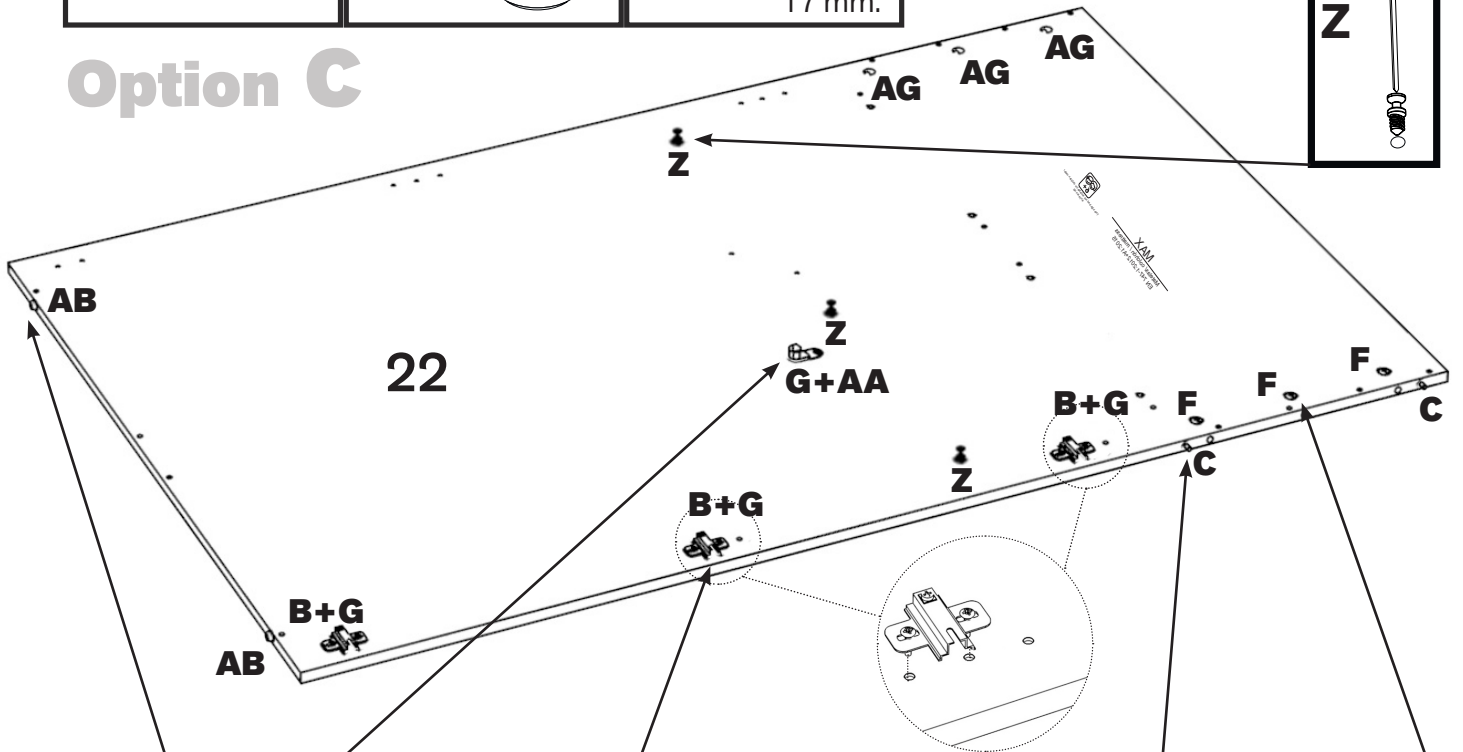

## Option D

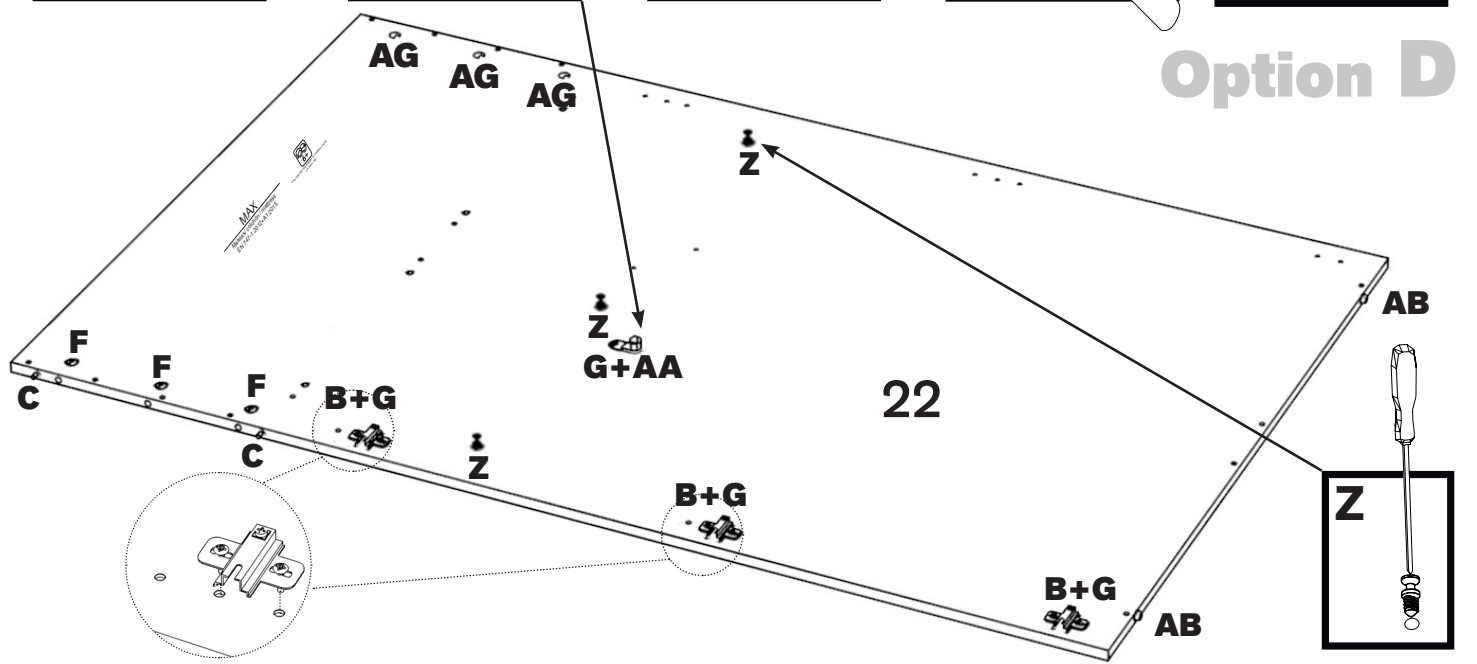

55

Y x 06

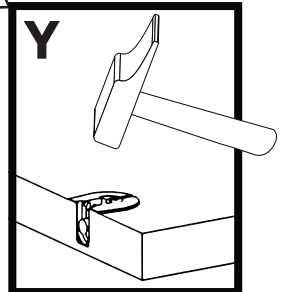
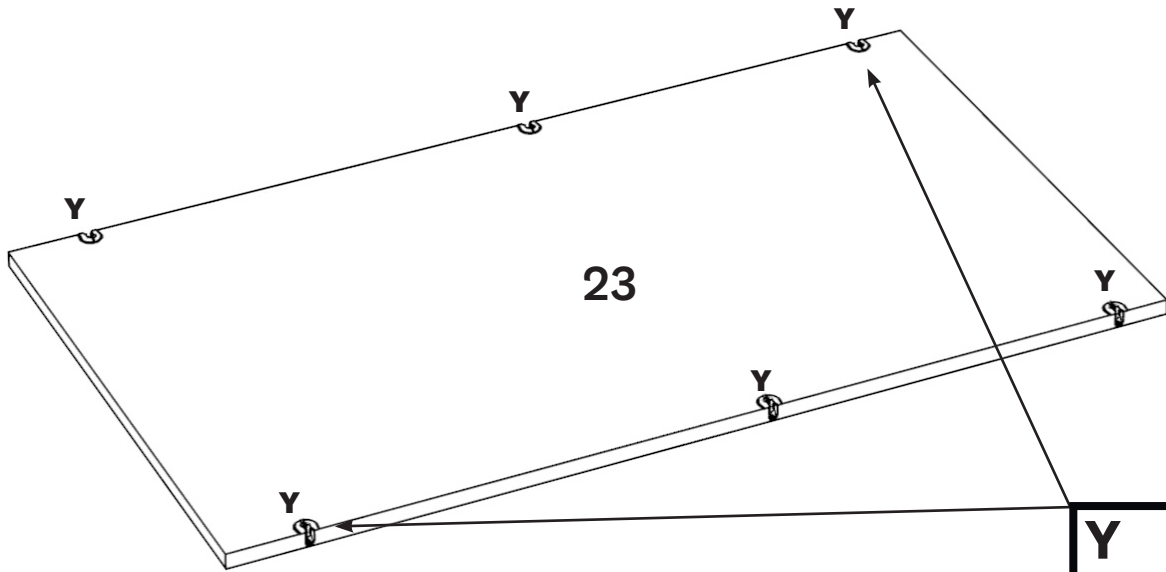
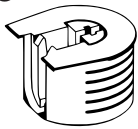

56

A x 03

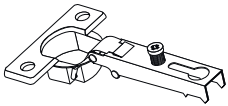

G x 06



3.5 x 15 mm.

AH x 02



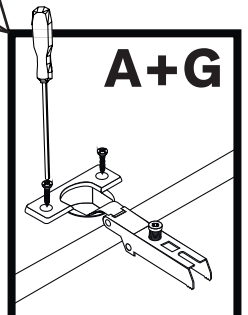
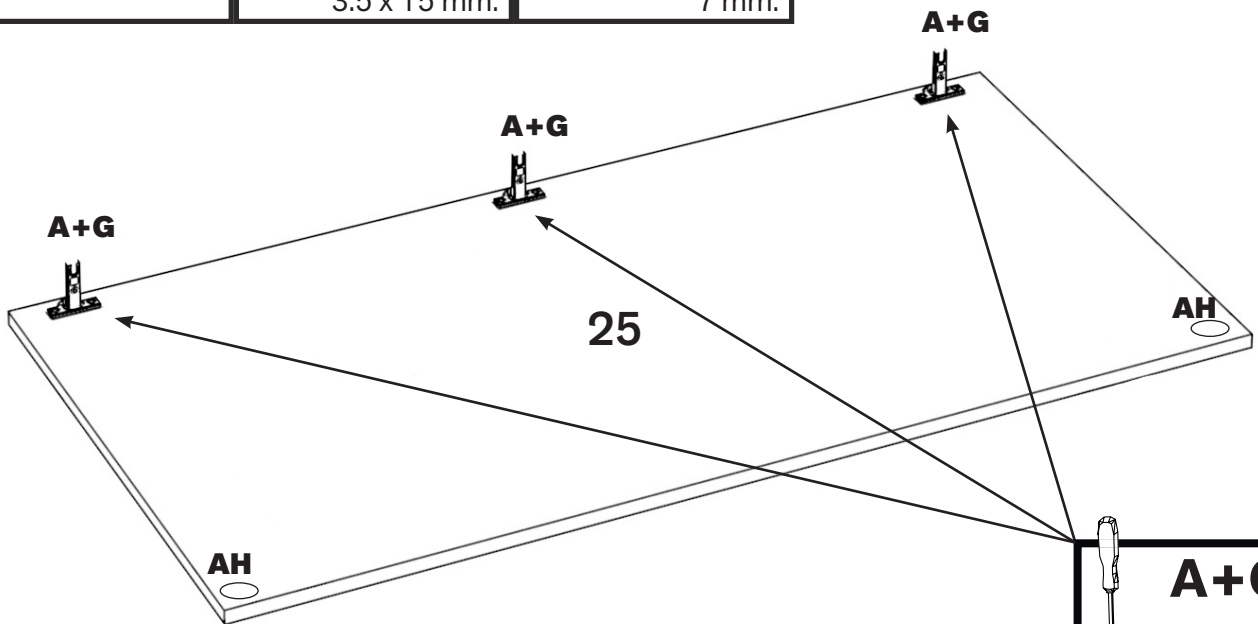

7 mm.

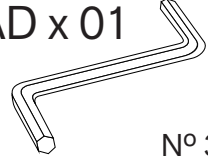

57

N x 08  
  
 5 x 60 mm.

AD x 01  
  
 Nº 3

AG x 04  
  
 17 mm.

# Option C

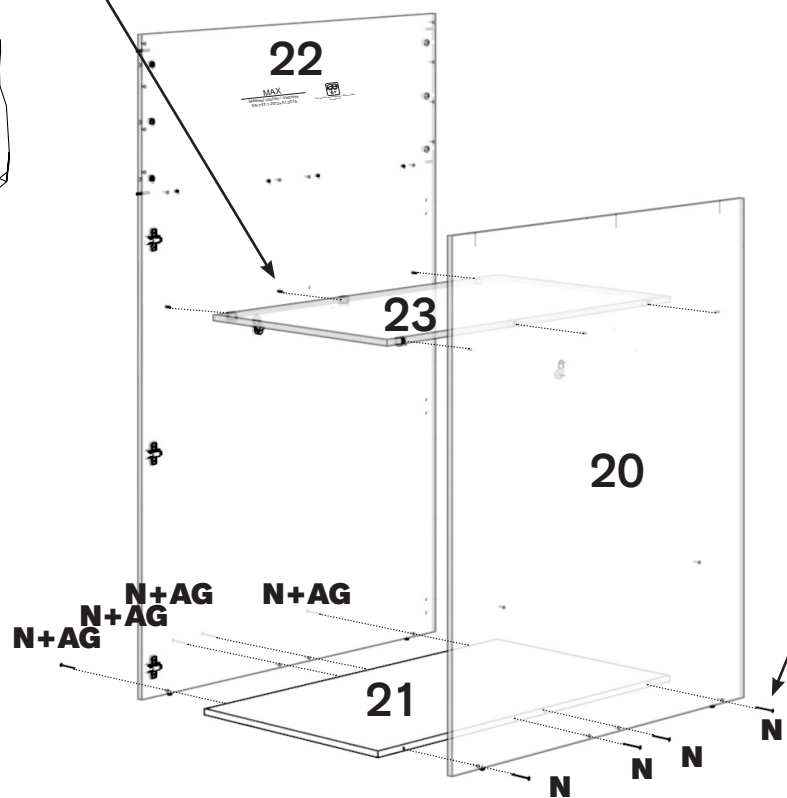
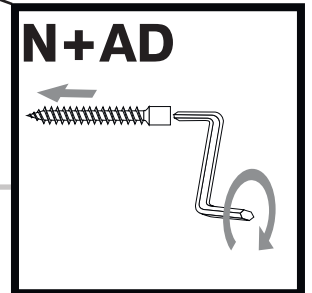
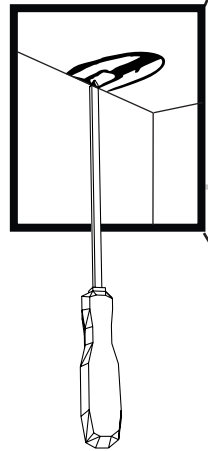
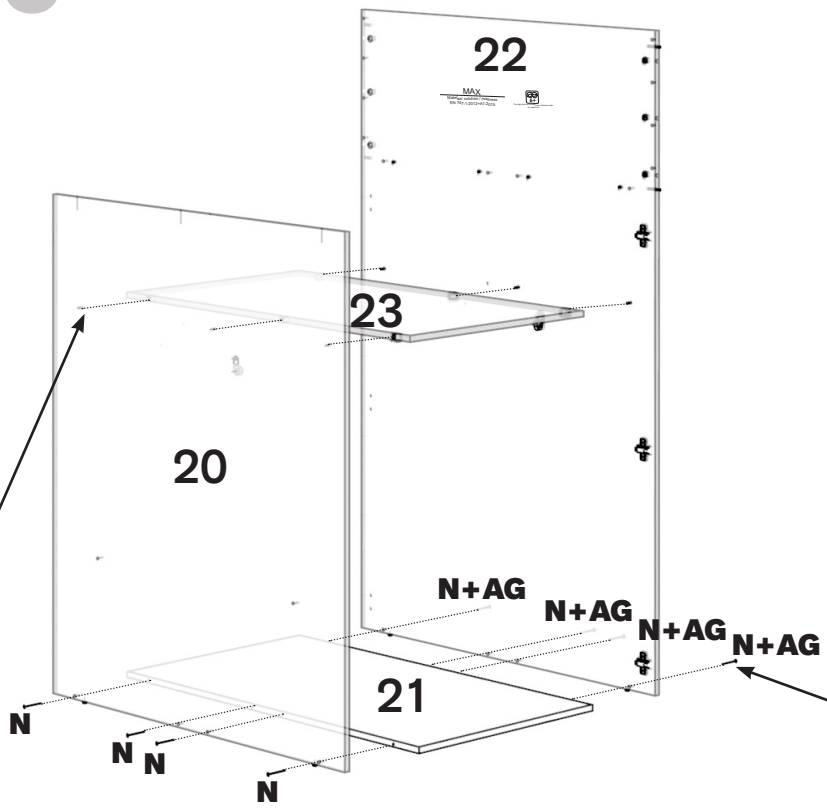

# Option D

58 C x 04

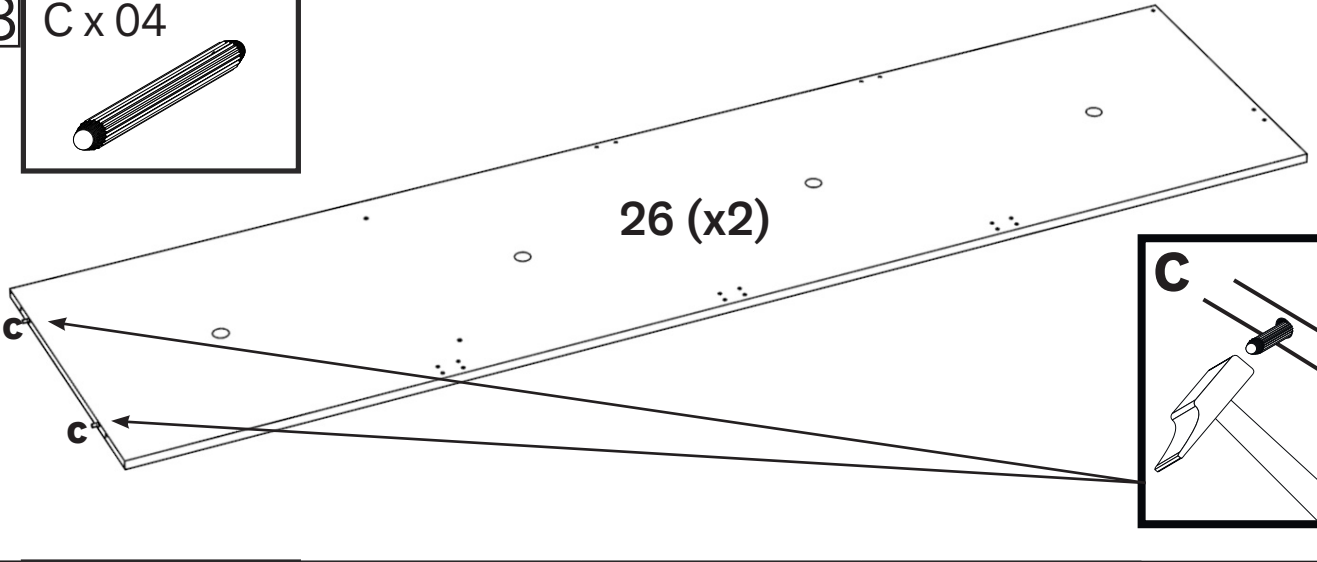
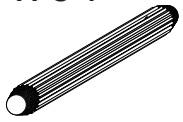

59 H x 04  
  
 4 x 16 mm.

K x 06  
  
 M4 x 10 mm.

L x 06  
  
 M4 x 15 mm.

U x 05

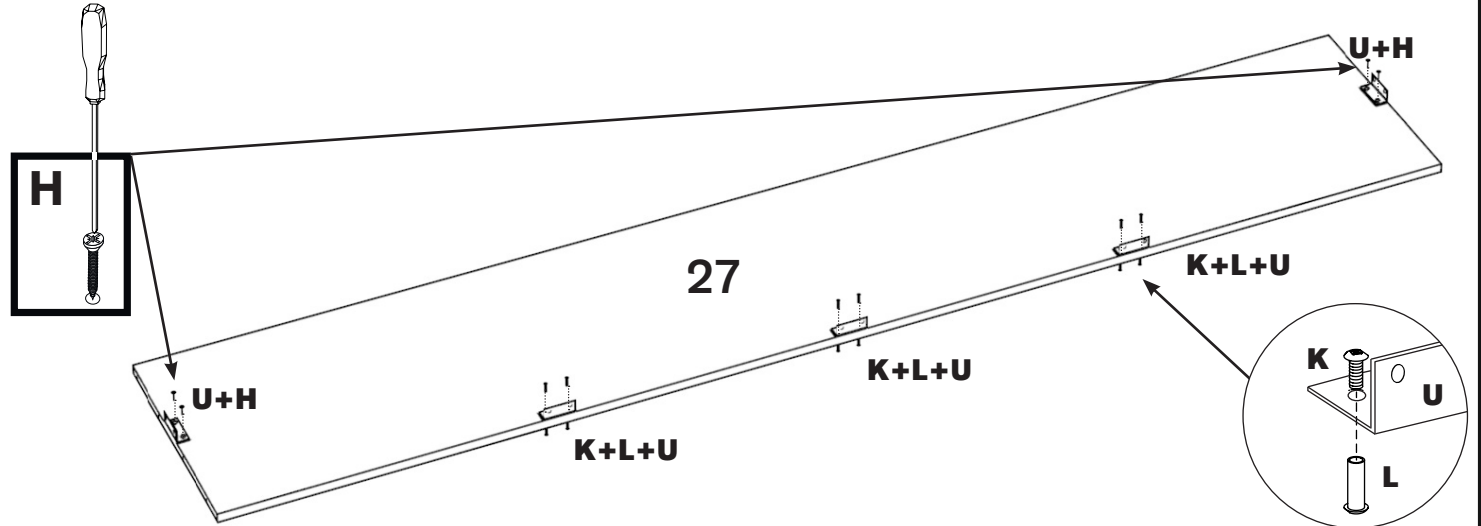

60 **Option C**

K x 06  
  
 M4 x 10 mm.

L x 06  
  
 M4 x 15 mm.

U x 03

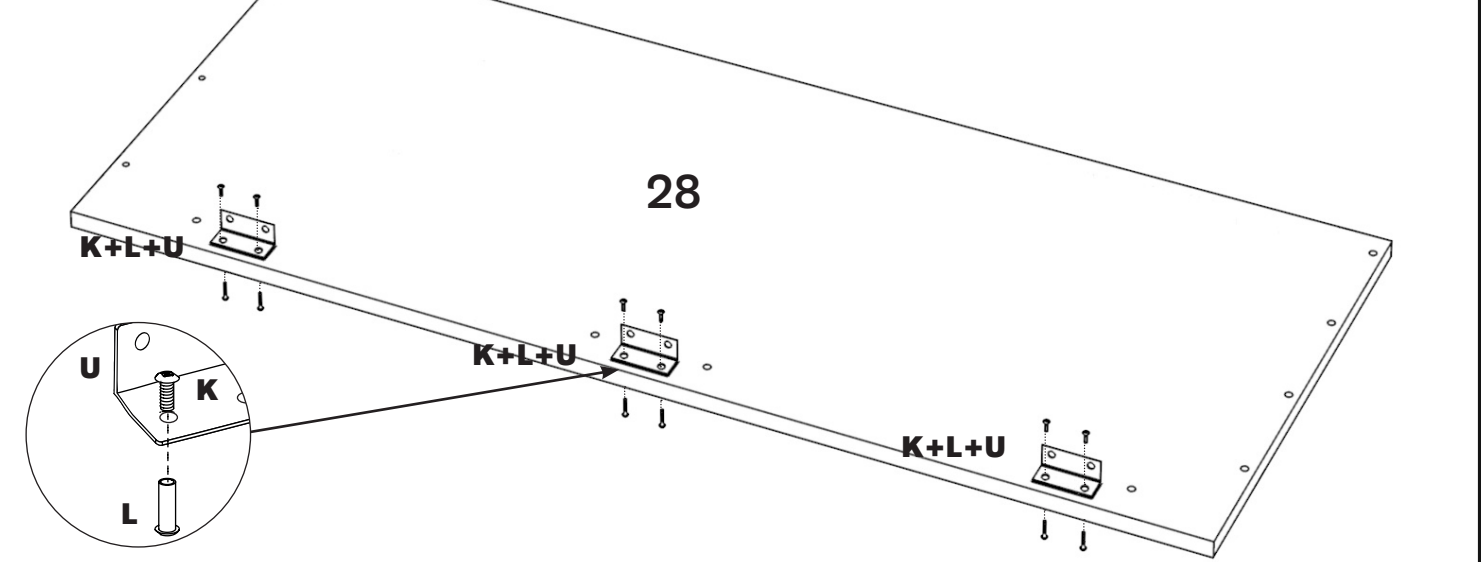

60

K x 06

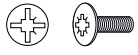

M4 x 10 mm.

L x 06



M4 x 15 mm.

U x 03

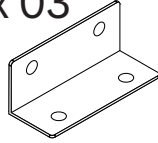

Option D

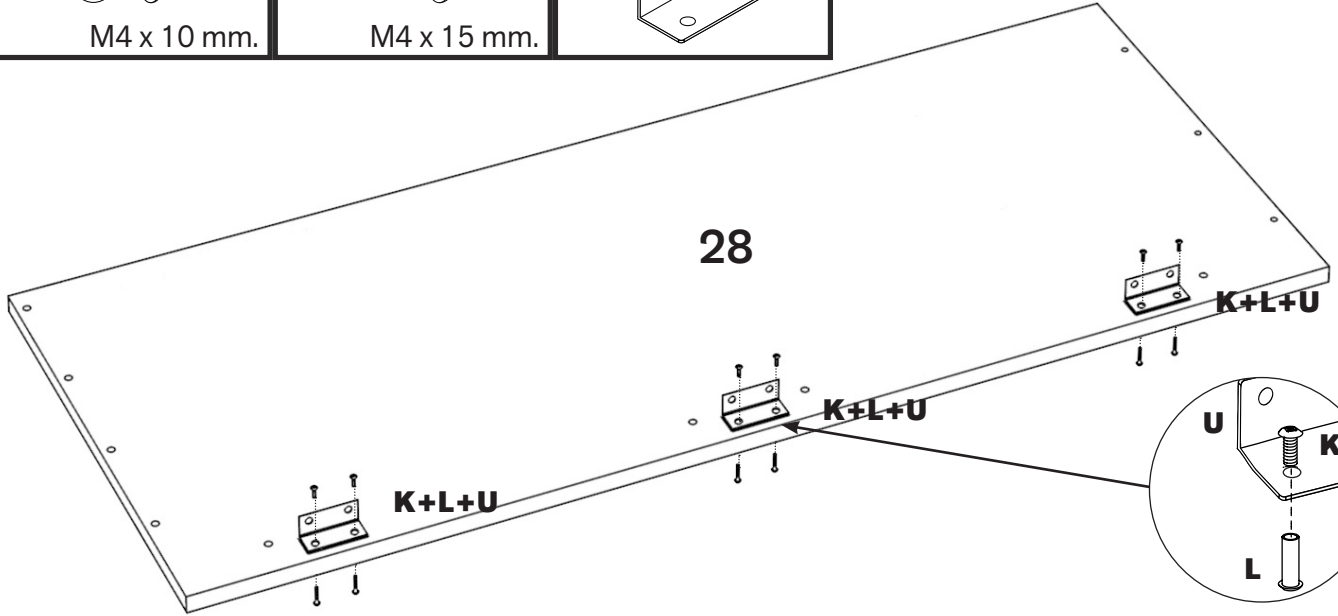

61

E x 03

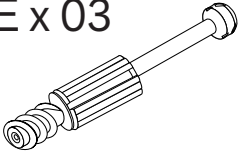

Y x 01

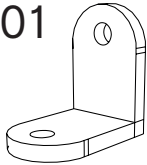

U x 03

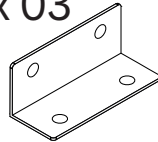

AK x 07

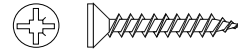

4 x 20 mm.

Option C

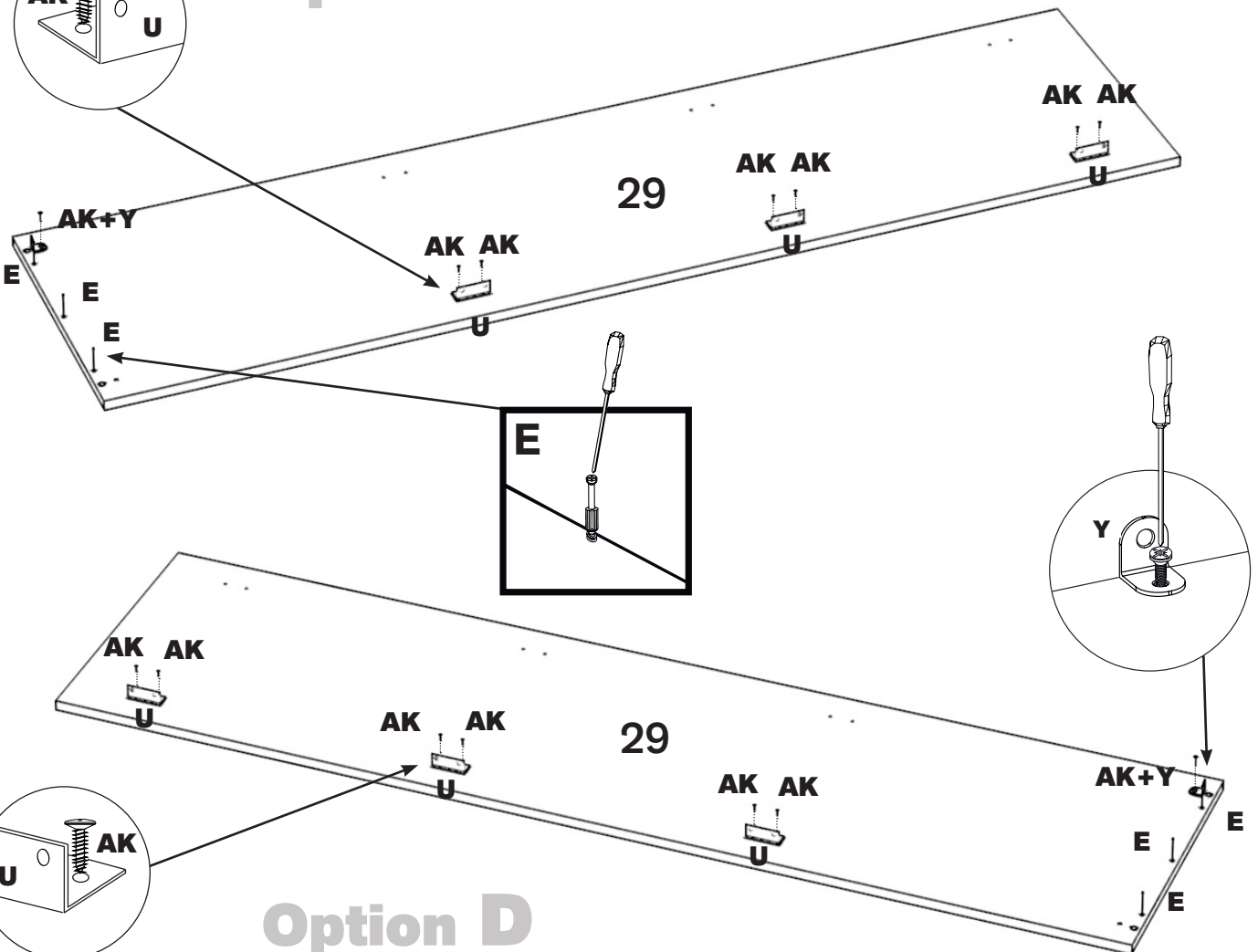
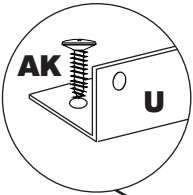

Option D

62

N x 08



5 x 60 mm.

AD x 01

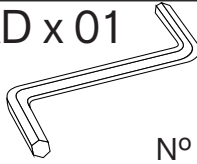

Nº 3

AG x 08



17 mm.

### Option C

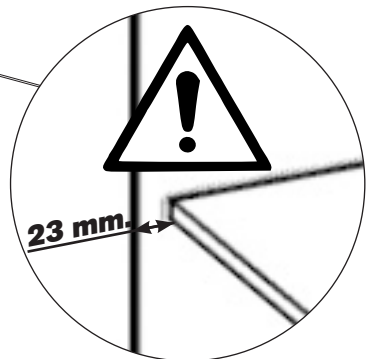
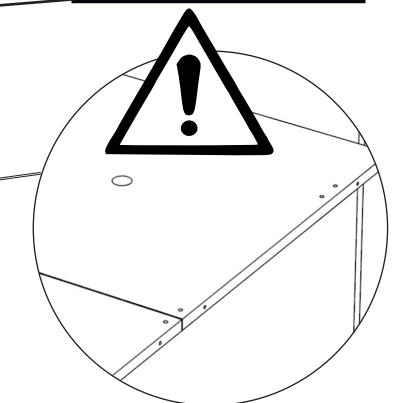
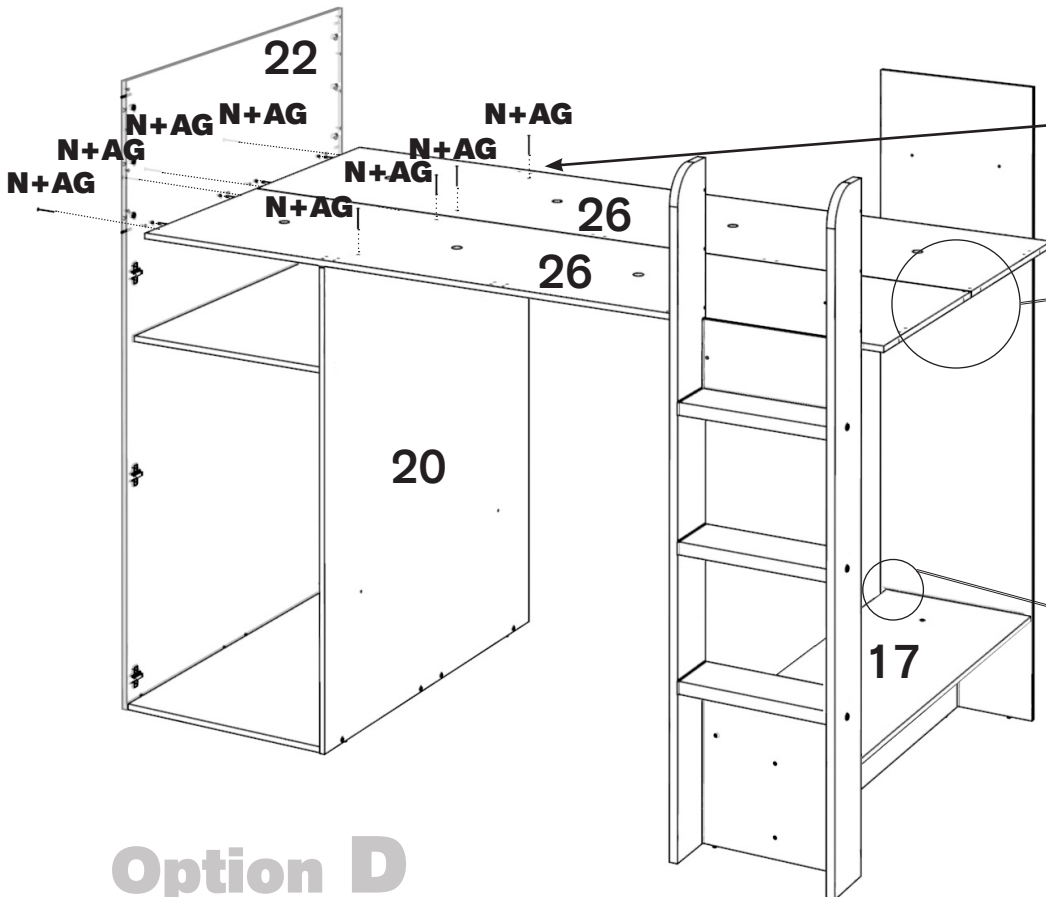
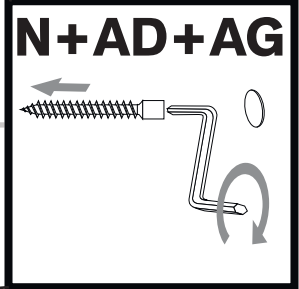
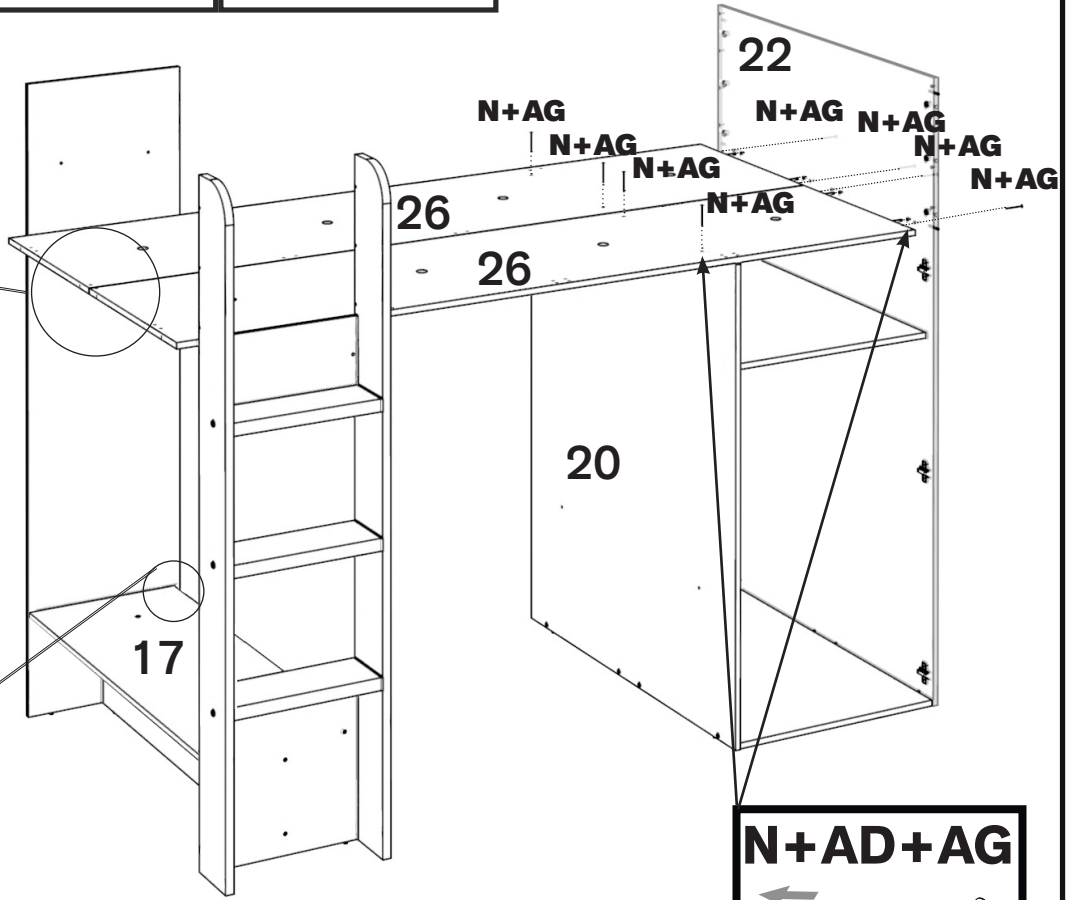
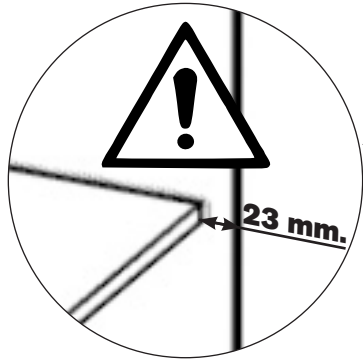
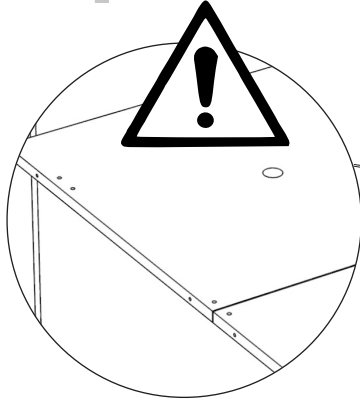

### Option D

63

G x 08

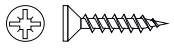

3.5 x 15 mm.

R x 30

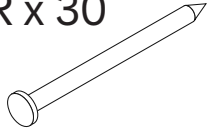

V x 02

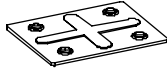

180°

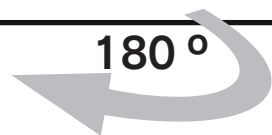

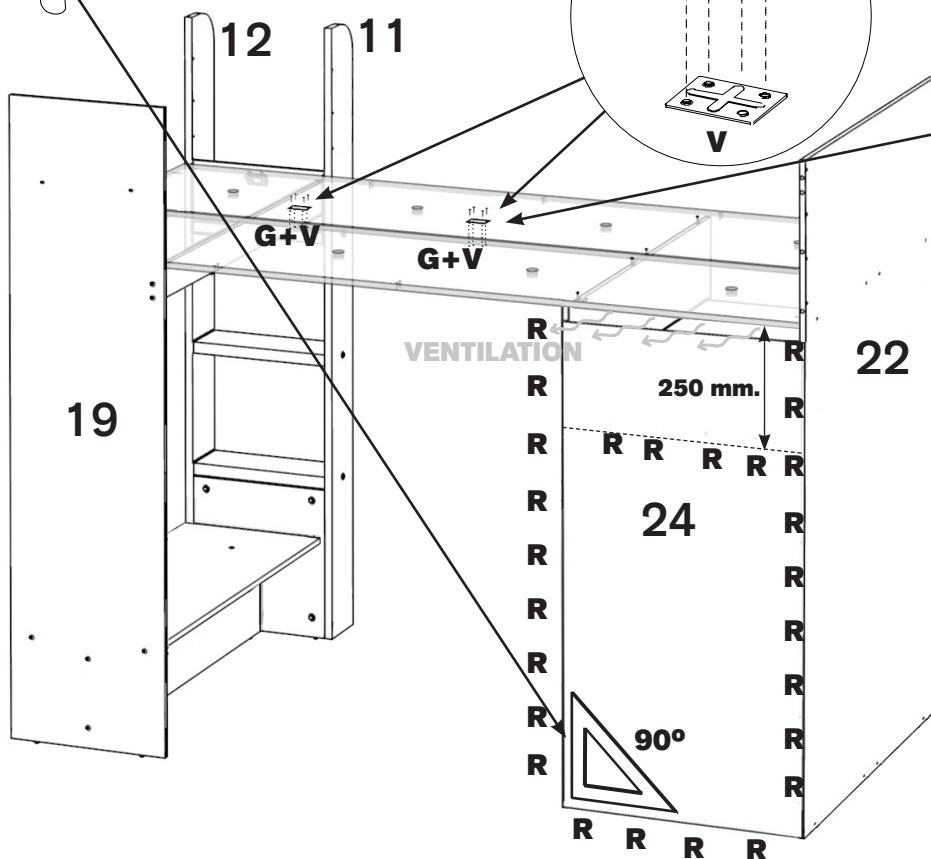
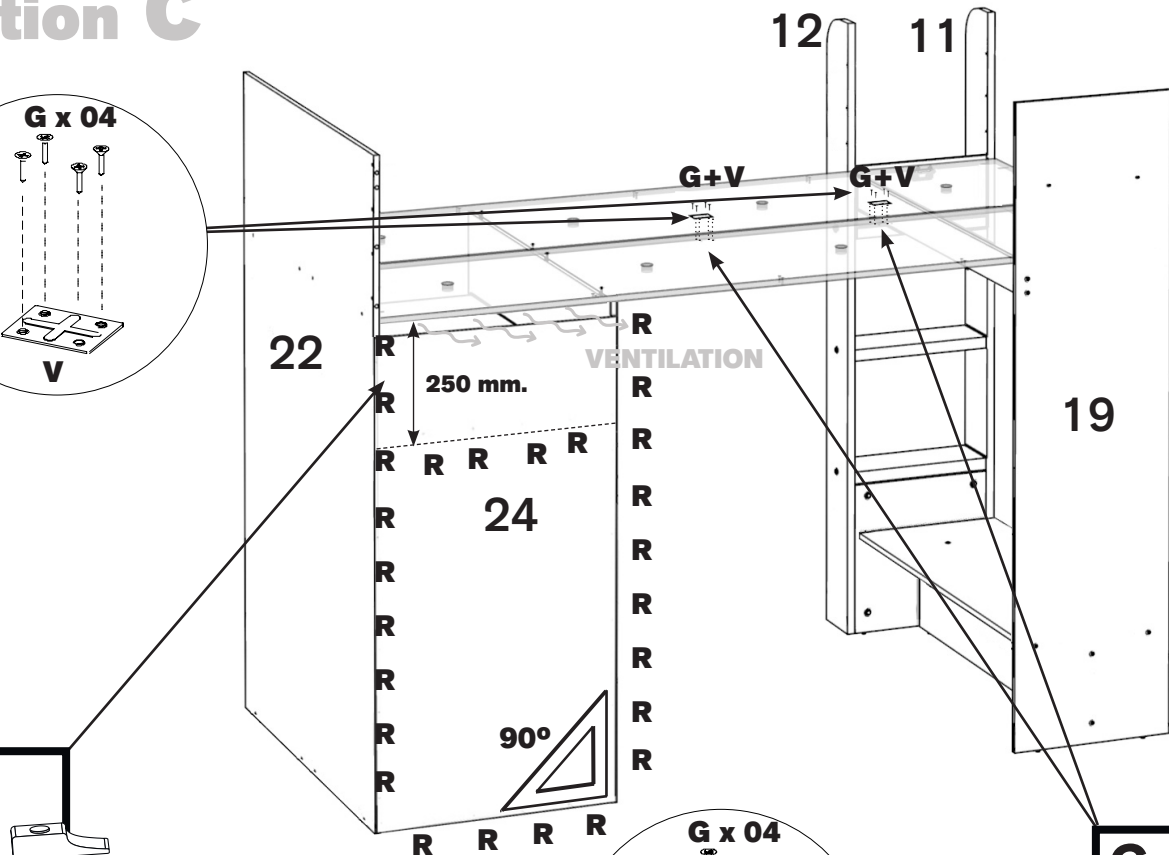
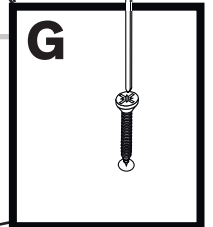
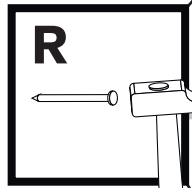
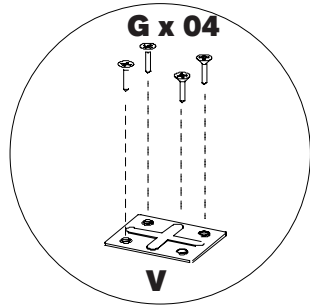

# Option C



# Option D

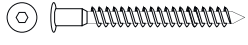
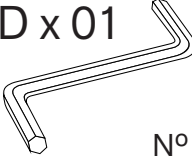
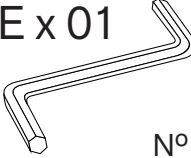

<b>64</b> N x 07  5 x 60 mm.	AD x 01  Nº 3	AE x 01  Nº 4	AG x 18  17 mm.
---	--	--	--

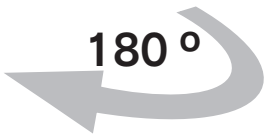

### Option C

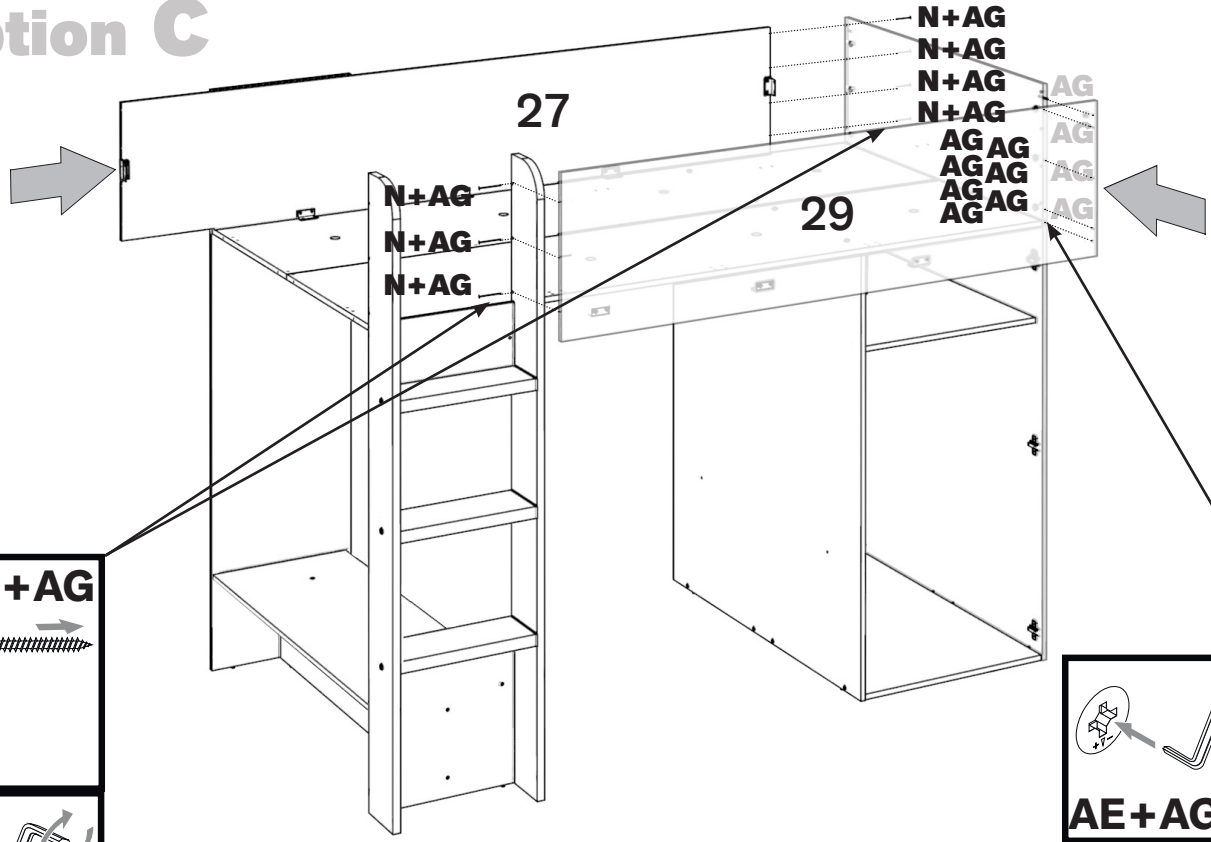

**N+AD+AG**

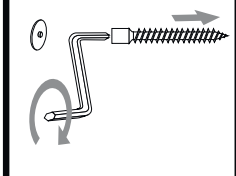

**AE+AG**

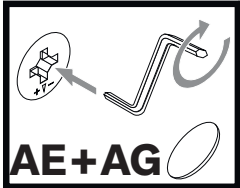
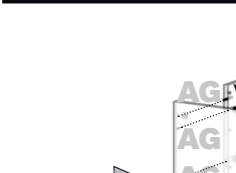

**AE+AG**

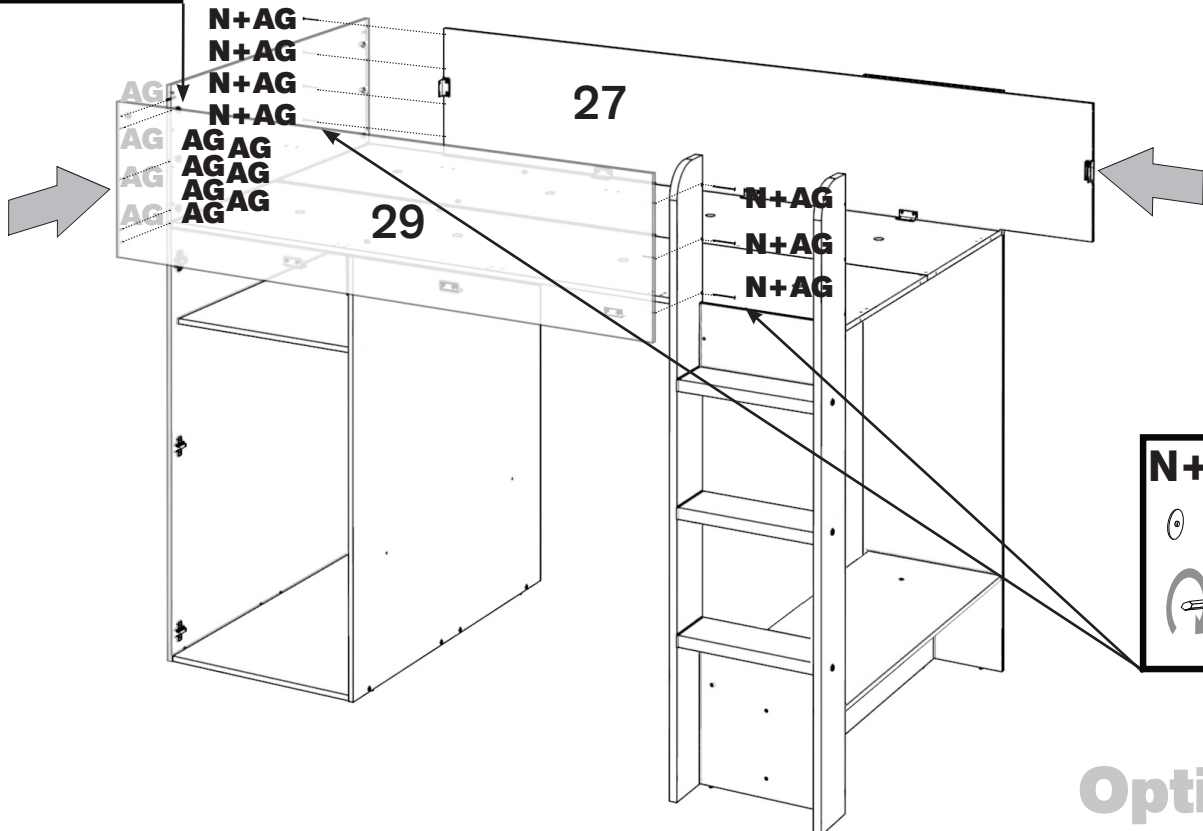

**N+AD+AG**

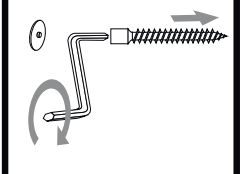

### Option D

65

H x 03



4 x 16 mm.

K x 12

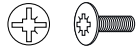

M4 x 10 mm.

L x 12



M4 x 15 mm.

M x 03



M4 x 15 mm.

N x 08



5 x 60 mm.

# Option C

AD x 01

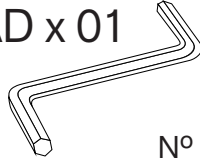

N° 3

AF x 03



M4 X 30 mm.

AG x 08



17 mm.

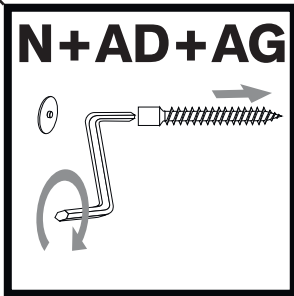
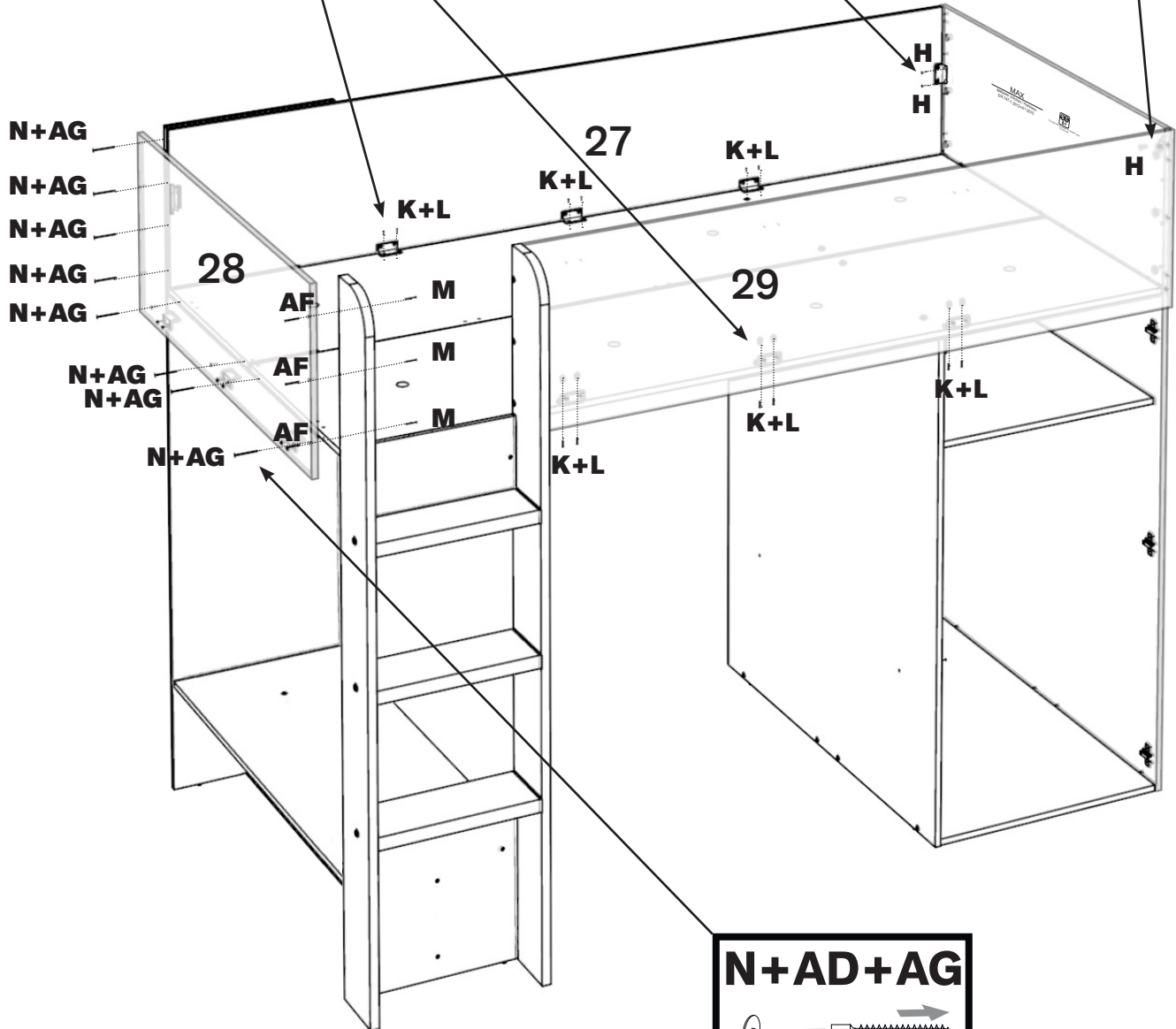
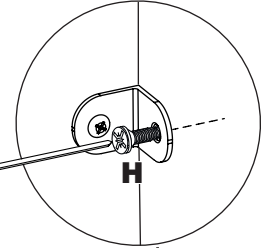
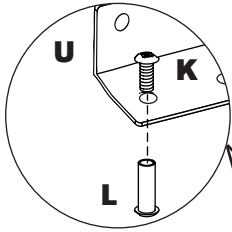

65

H x 03



4 x 16 mm.

K x 12



M4 x 10 mm.

L x 12



M4 x 15 mm.

M x 03

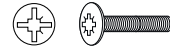

M4 x 15 mm.

N x 08



5 x 60 mm.

# Option D

AD x 01

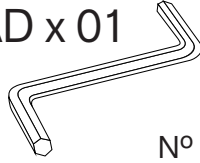

N° 3

AF x 03



M4 X 30 mm.

AG x 08



17 mm.

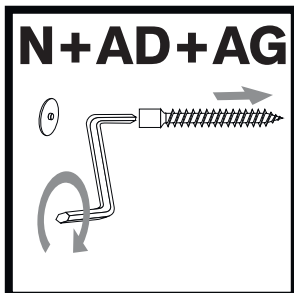
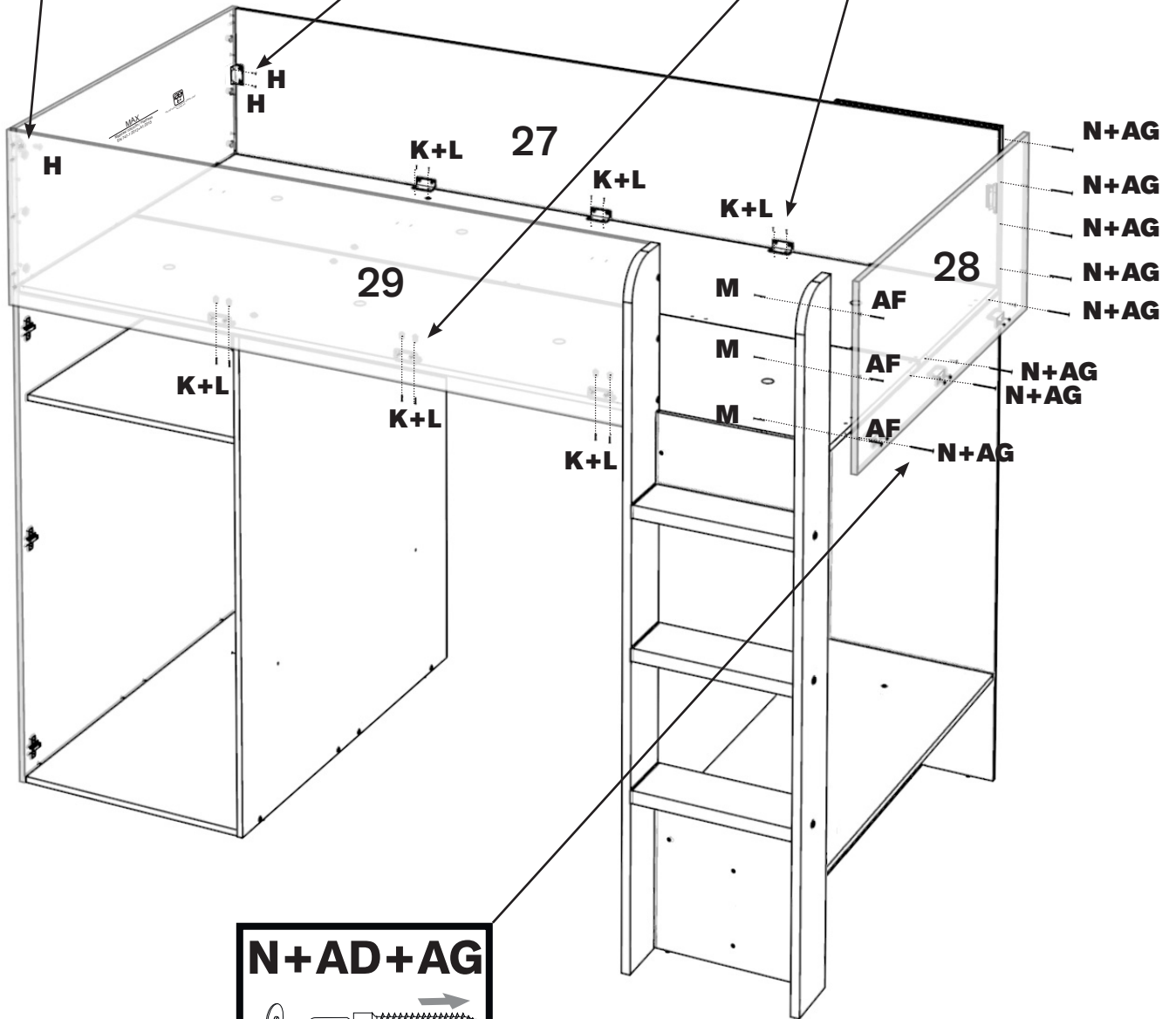
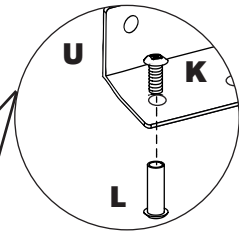
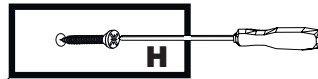
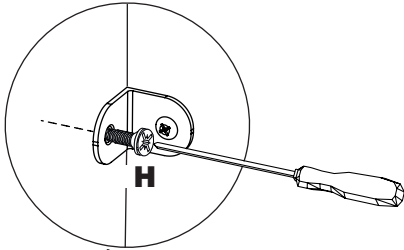

66

G x 02

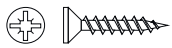

3.5 x 15 mm.

H x 02



4 x 16 mm.

J x 02

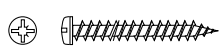

4 x 30 mm.

K x 06

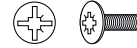

M4 x 10 mm.

L x 06



M4 x 15 mm.

## Option C

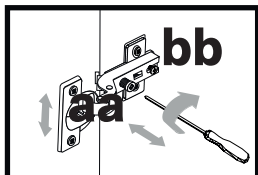
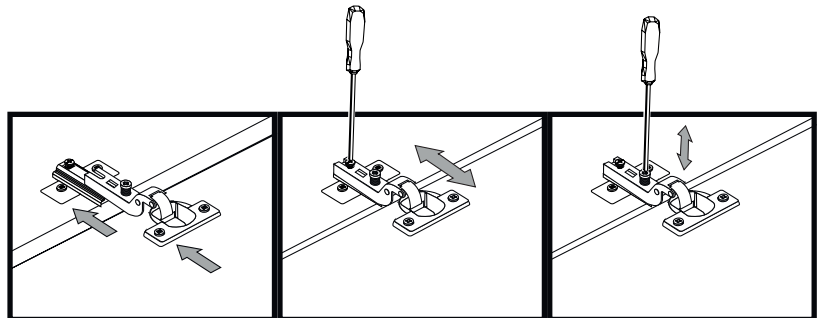
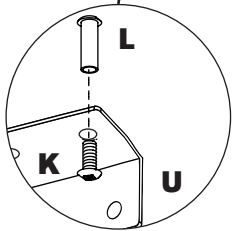
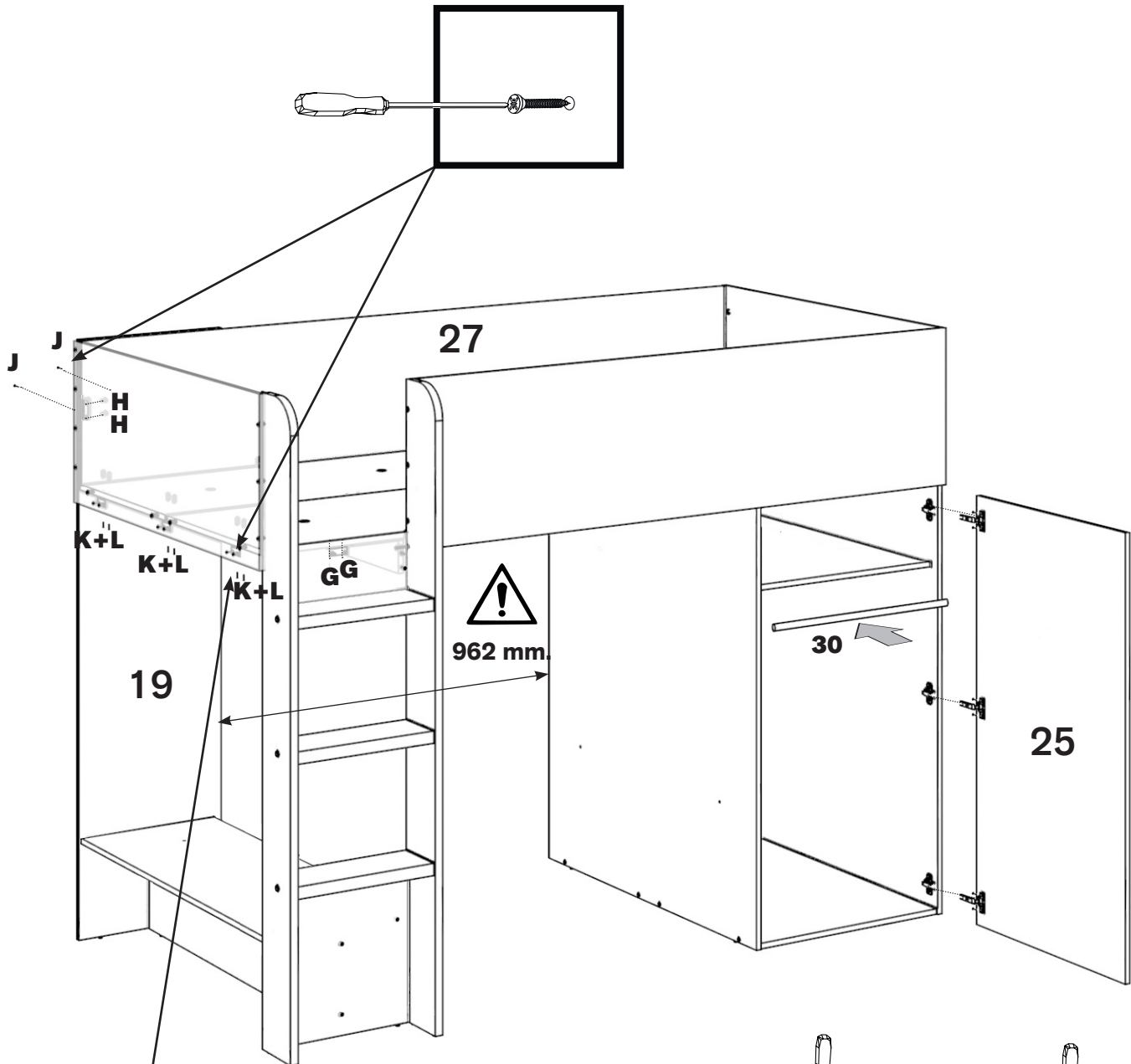
**EN**

Before to tighten the screw "aa", you have to slacken a little the screw "bb"

**ES**

Antes de apretar el tornillo "aa", hay que aflojar un poco el tornillo "bb"

**FR**

Avant de presser le vis "aa", il y a que relâcher un peu le vis "bb"

**PT**



Antes de apertar o parafuso "aa", deve desapertar um pouco o parafuso "bb"

**NL**

Voordat de schroef "aa" wordt vastgedraaid, moet de schroef "bb" enigszins worden losgedraaid

**DE**

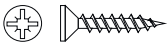
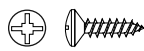
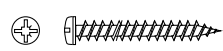
Bevor die Schraube "aa" festgezogen wird lösen Sie ein wenig die schraub "bb"

<b>66</b> G x 02  3.5 x 15 mm.	H x 02  4 x 16 mm.	J x 02  4 x 30 mm.	K x 06  M4 x 10 mm.	L x 06  M4 x 15 mm.
---	---	---	--	--

# Option D

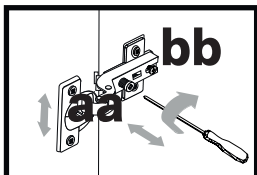
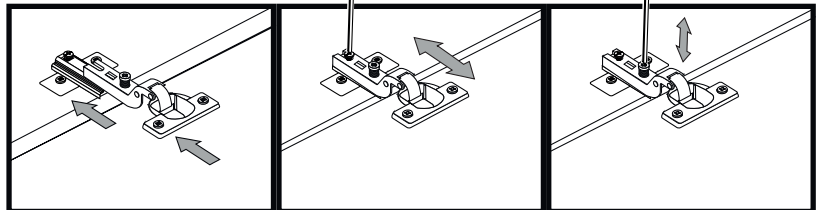
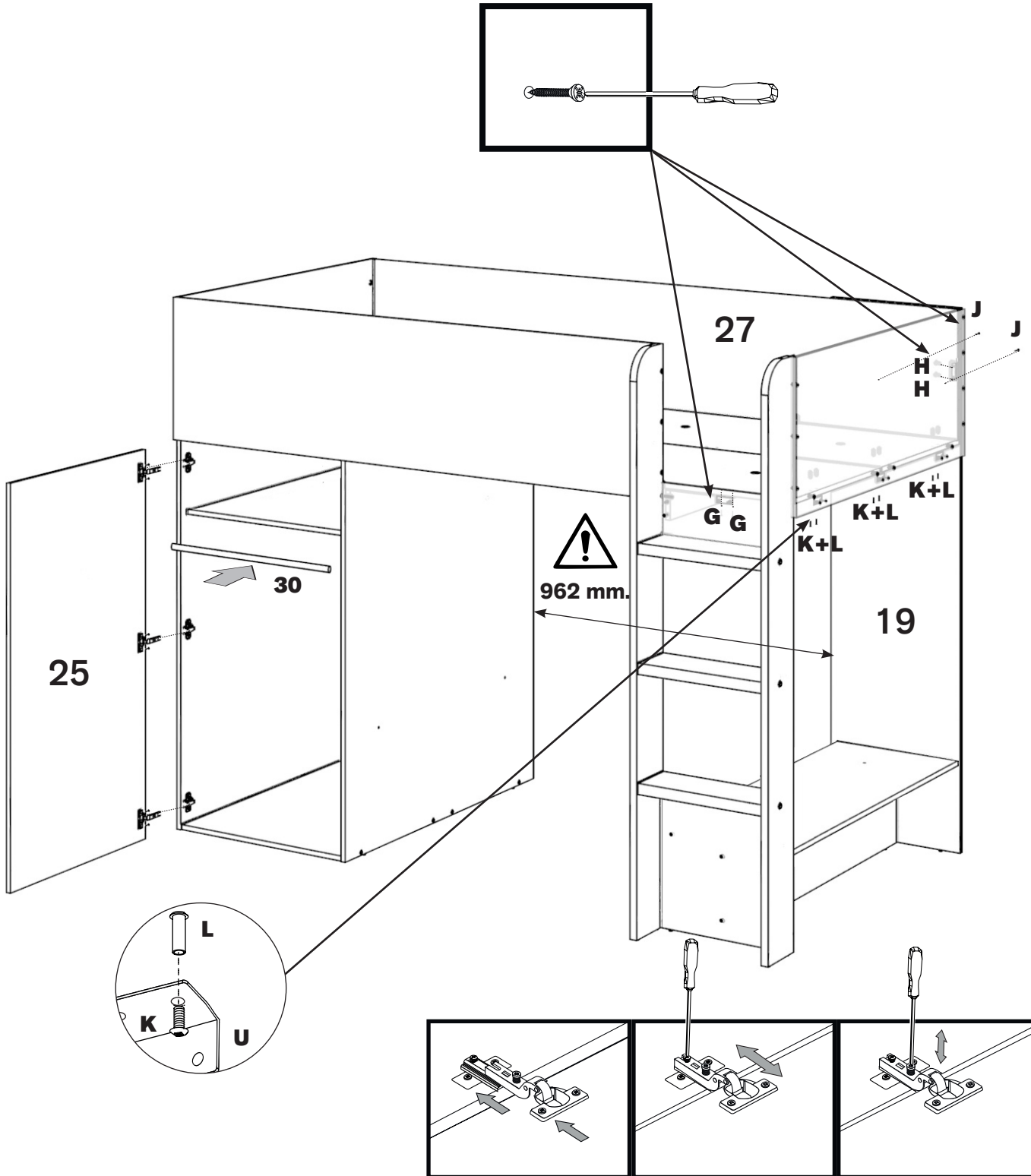

**EN**  
 Before to tighten the screw "aa", you have to slacken a little the screw "bb"  
**ES**  
 Antes de apretar el tornillo "aa", hay que aflojar un poco el tornillo "bb"  
**FR**  
 Avant de presser le vis "aa", il y a que relâcher un peu le vis "bb"

**PT**  
 Antes de apertar o parafuso "aa", deve desapertar um pouco o parafuso "bb"  
**NL**  
 Voordat de schroef "aa" wordt vastgedraaid, moet de schroef "bb" enigszins worden losgedraaid  
**DE**  
 Bevor die Schraube "aa" festgezogen wird lösen Sie ein wenig die schraub "bb"

# Option C

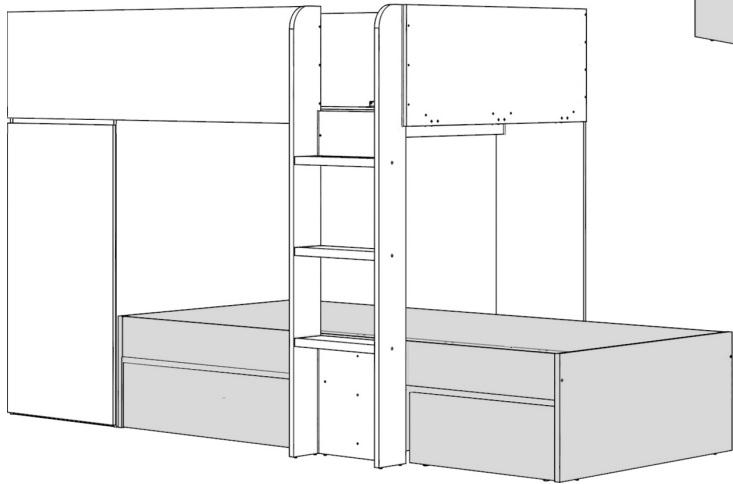
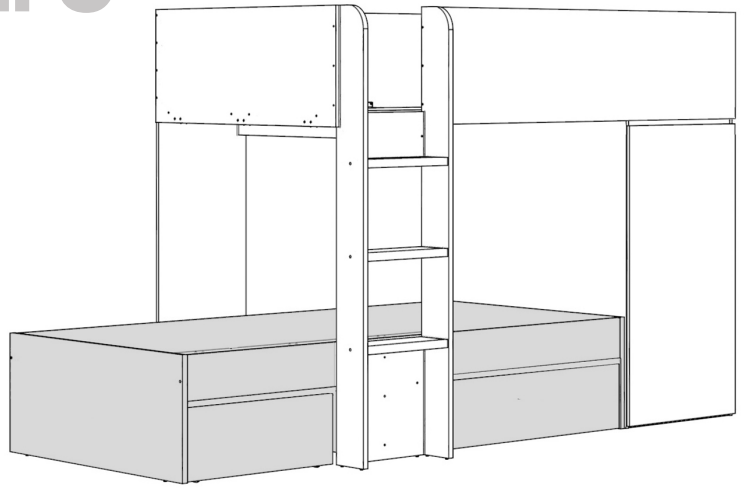

# Option D

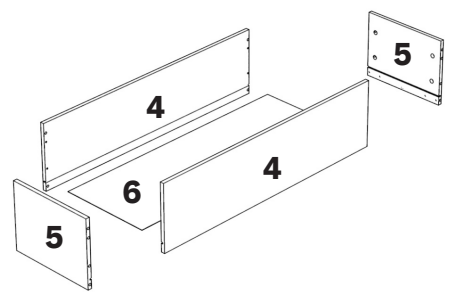
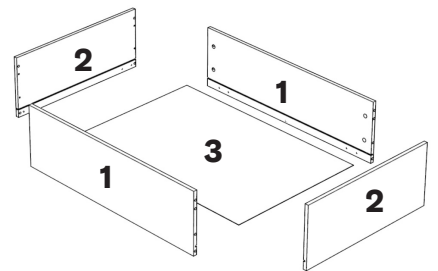
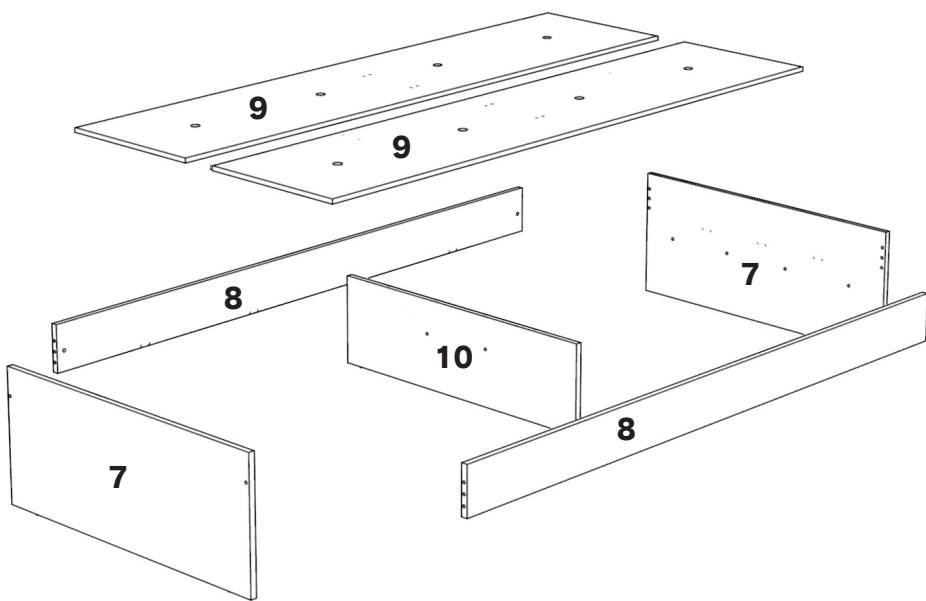

67

AK x 12

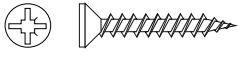

4 x 20 mm.

U x 06

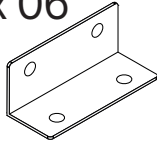

AB x 04

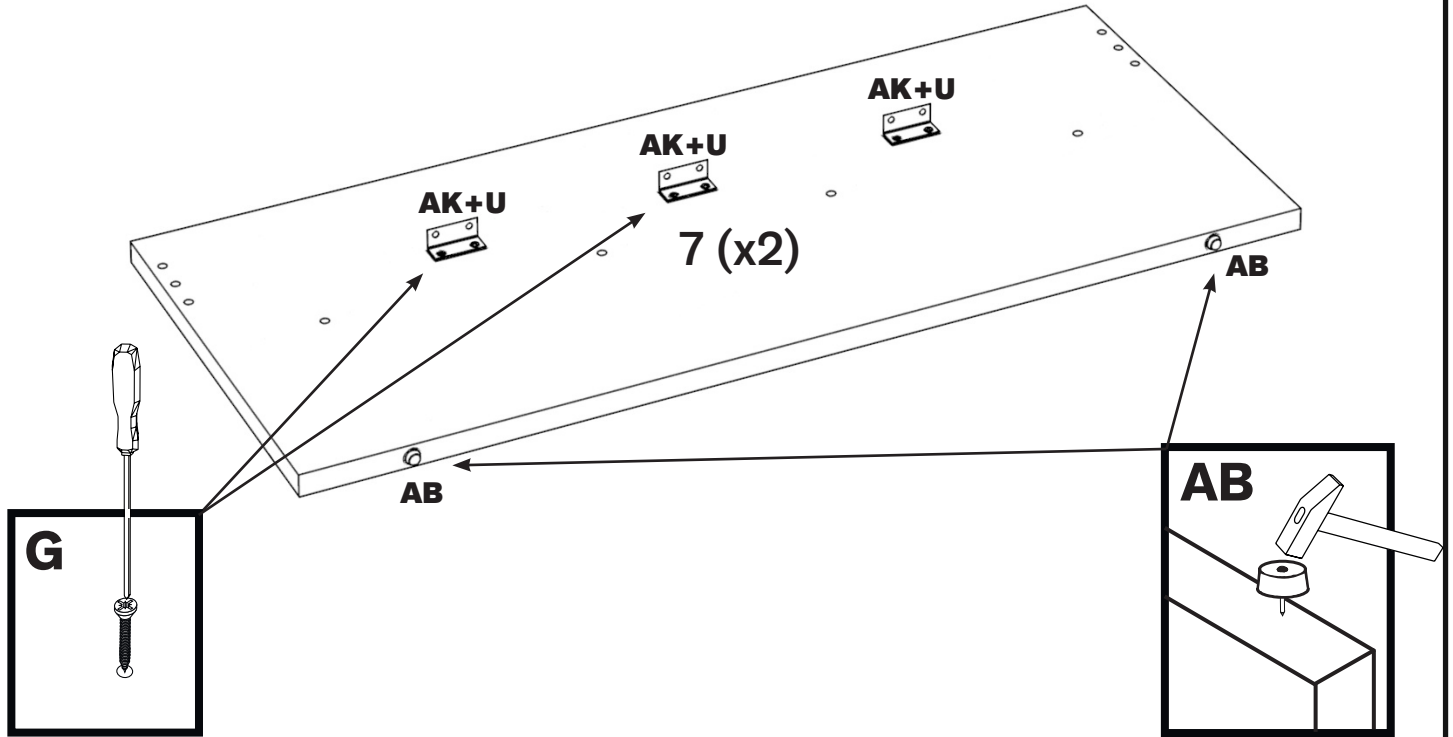

68

C x 08

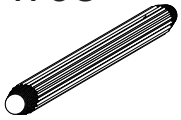

AK x 16

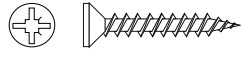

4 x 20 mm.

O x 04



13 mm.

U x 08

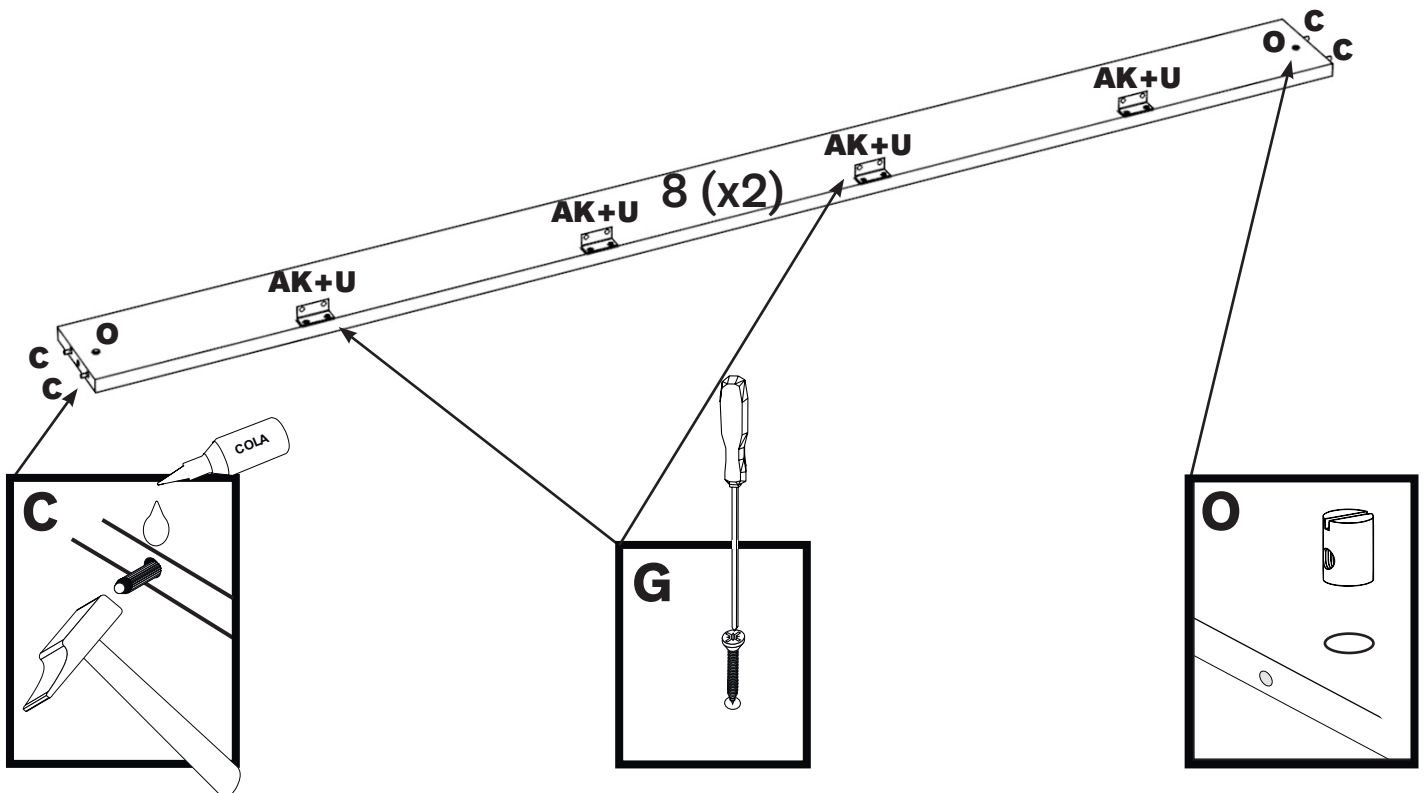
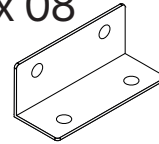

69

H x 08

W x 02

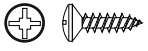

4 x 16 mm.

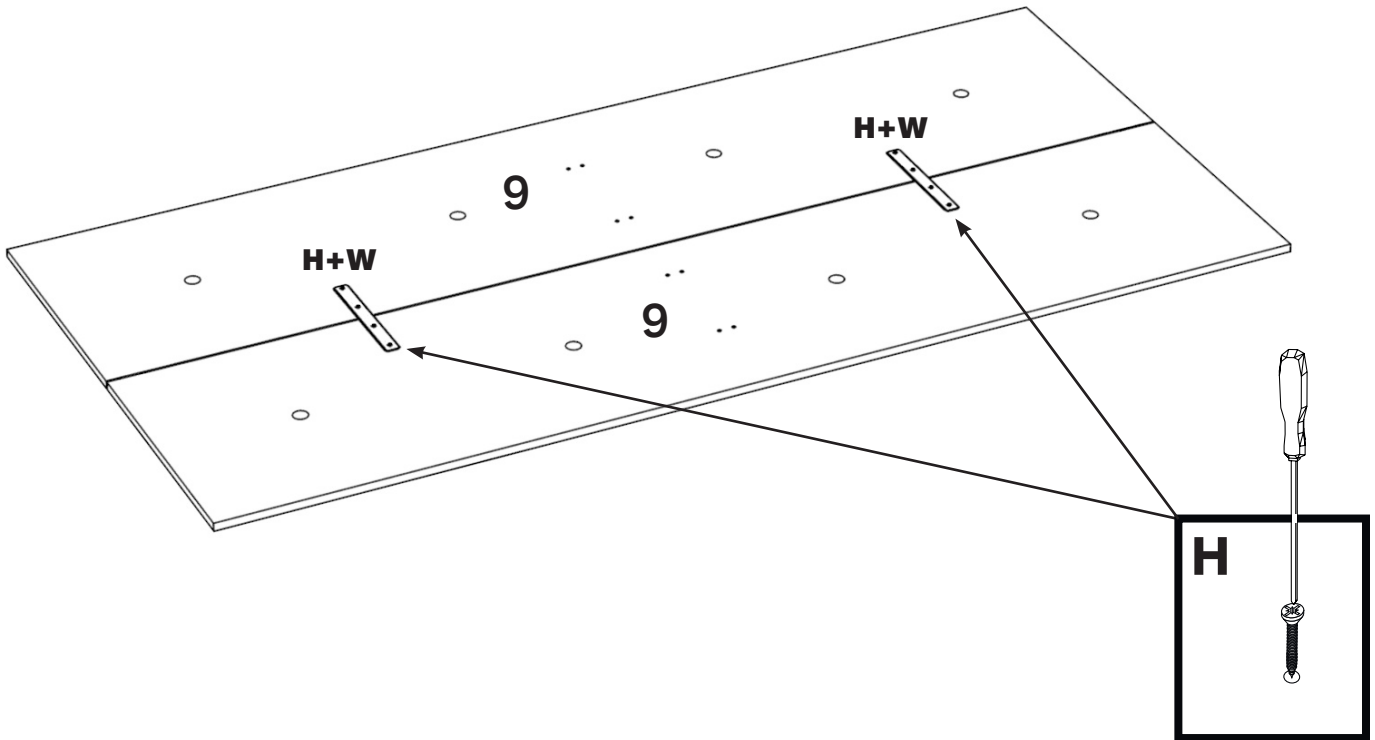
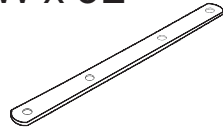

70

AB x 02

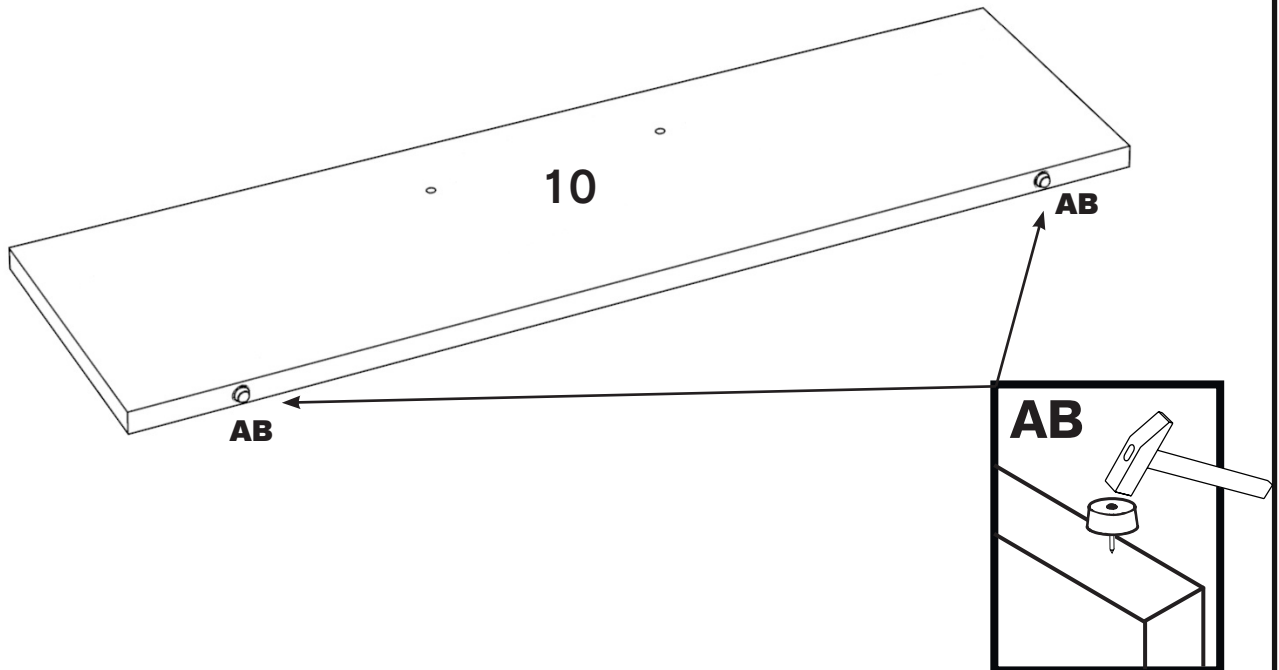
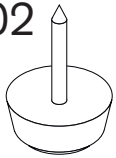



71

$\tilde{N} \times 04$

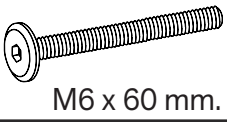

S x 02

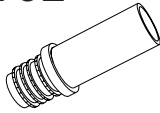

AE x 01

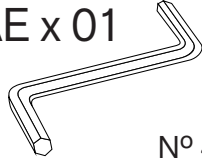

# Option C

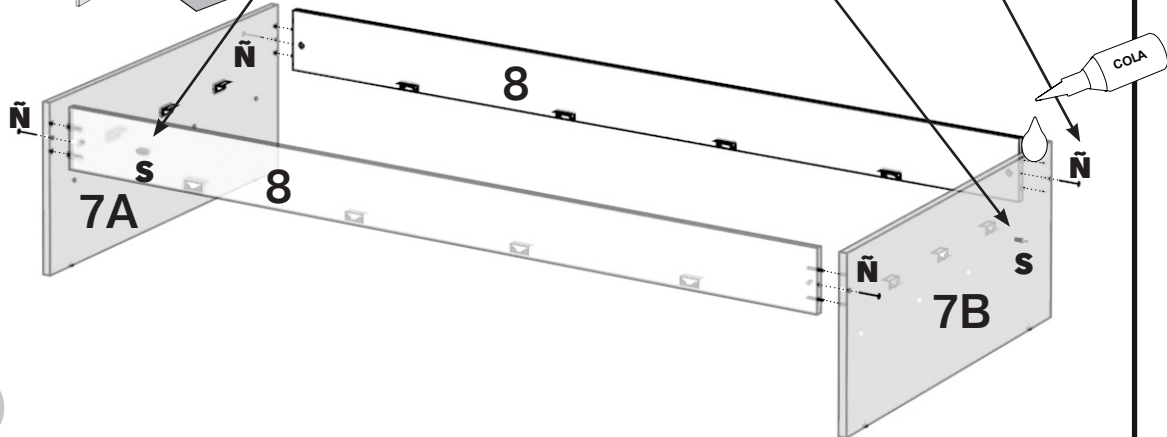
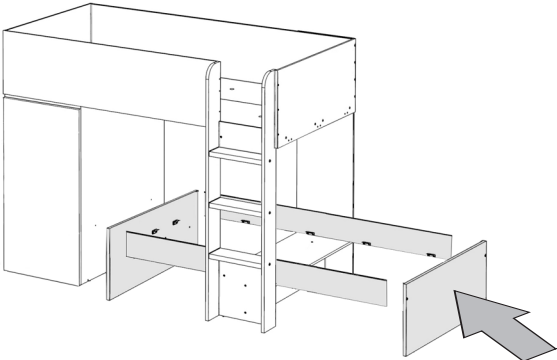
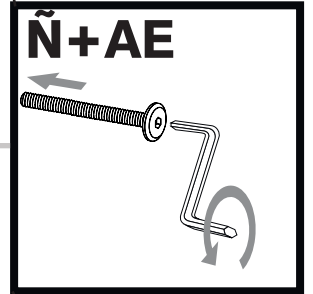
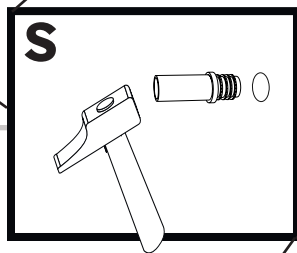
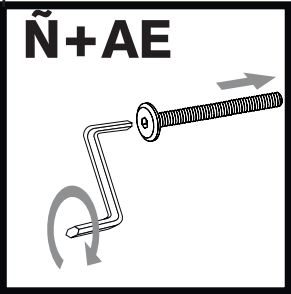
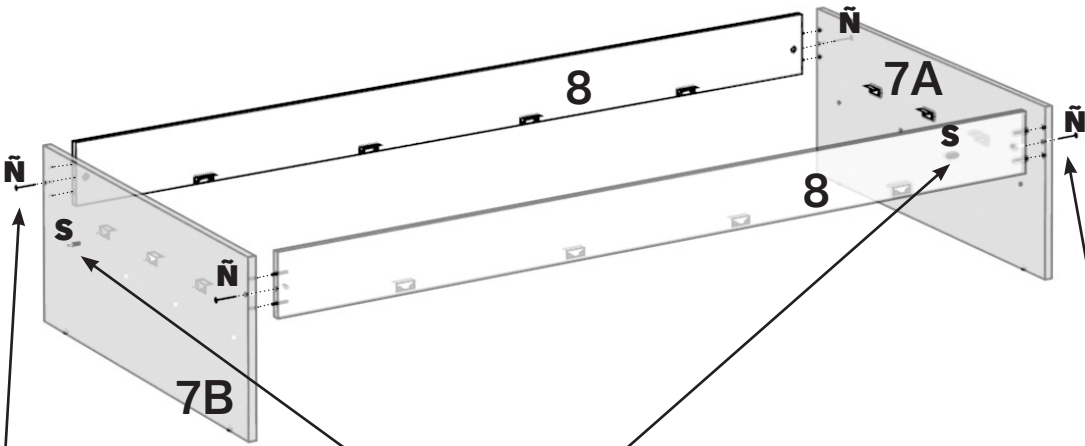
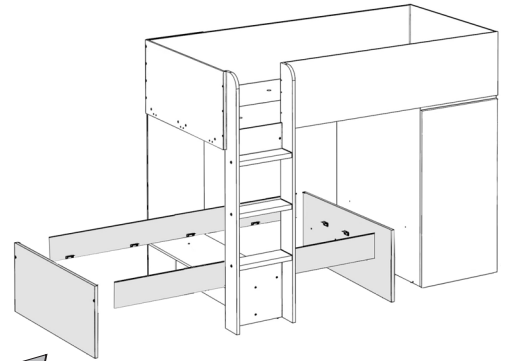

# Option D

72

N x 04



5 x 60 mm.

S x 01

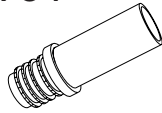

AD x 01

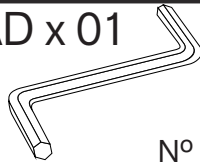

Nº 3

# Option C

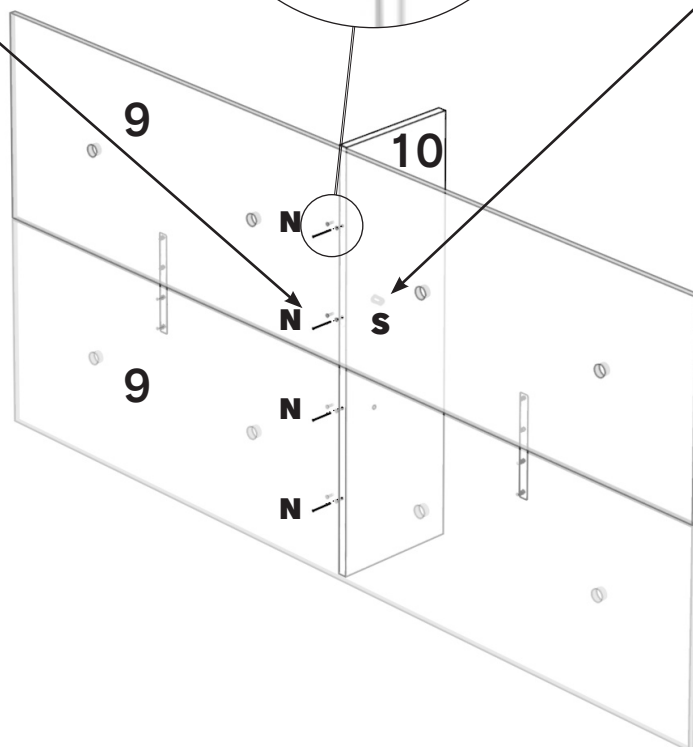
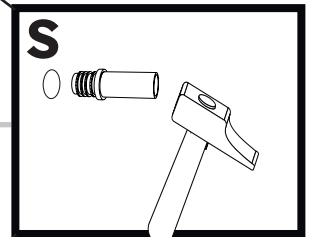
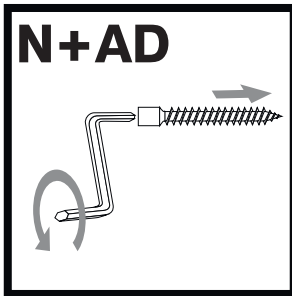
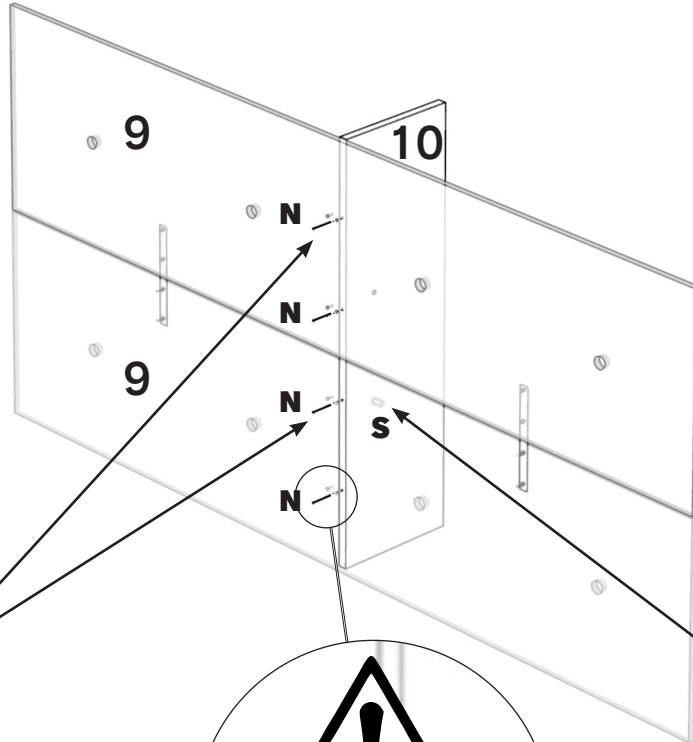

# Option D

73 E x 08

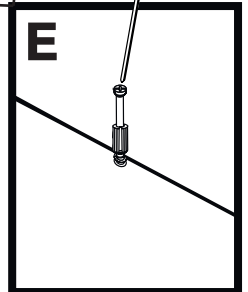
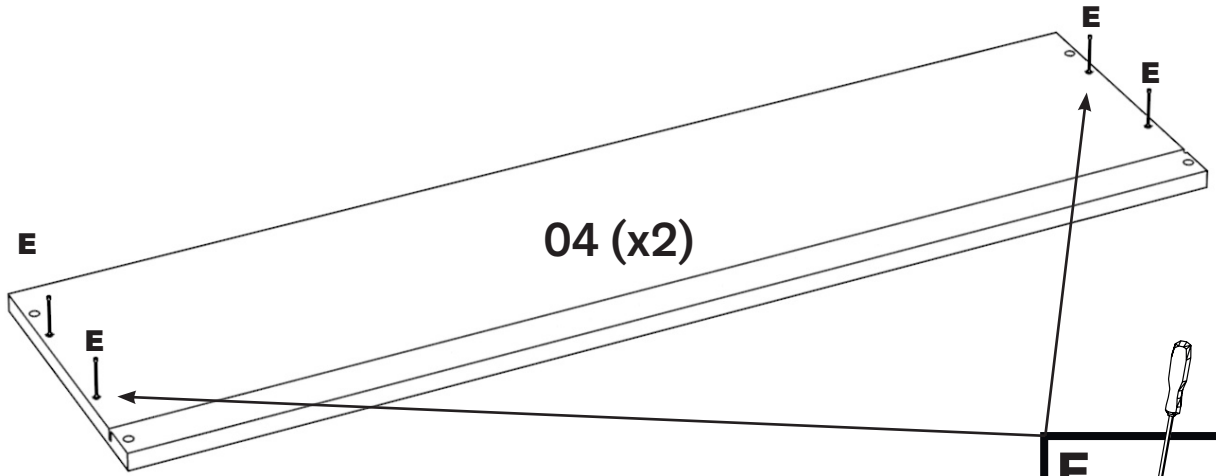
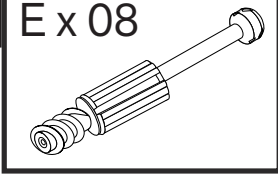

74 C x 08

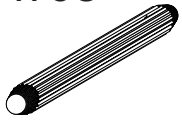

F x 08

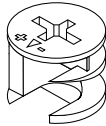

G x 08

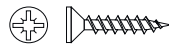

3.5 x 15 mm.

AC x 04

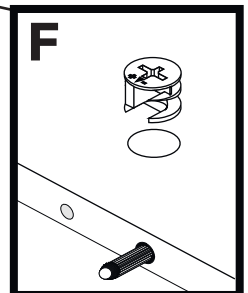
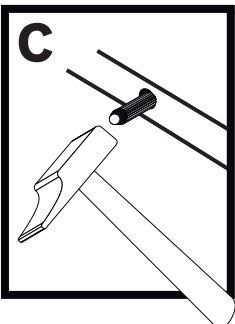
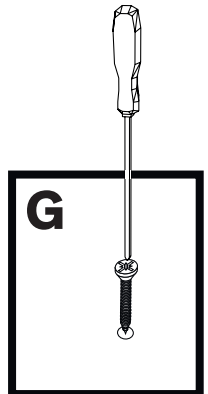
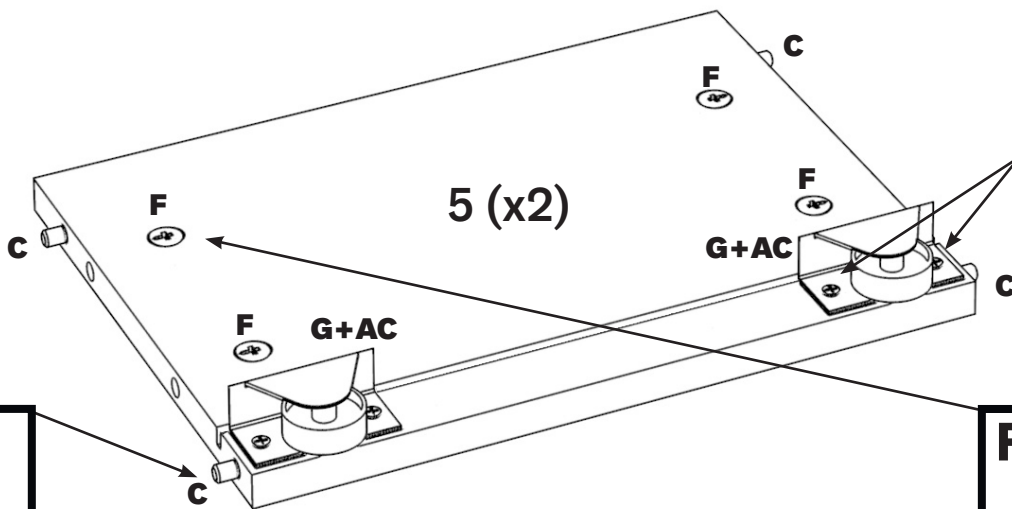
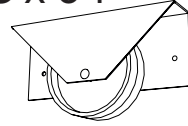

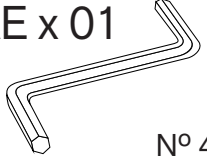
**75** AE x 01  N° 4

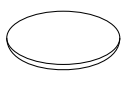
AG x 08  17 mm.

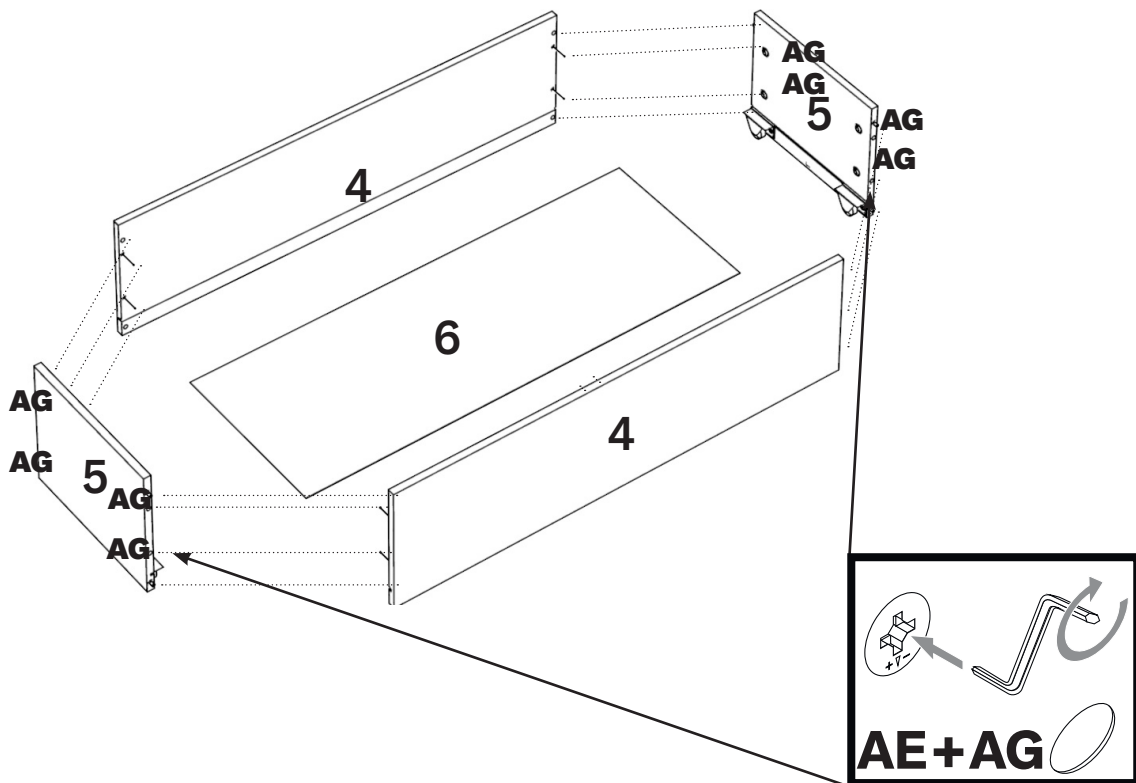

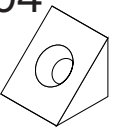
**76** AI x 04 

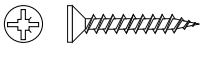
AJ x 04  3.5 x 20 mm.

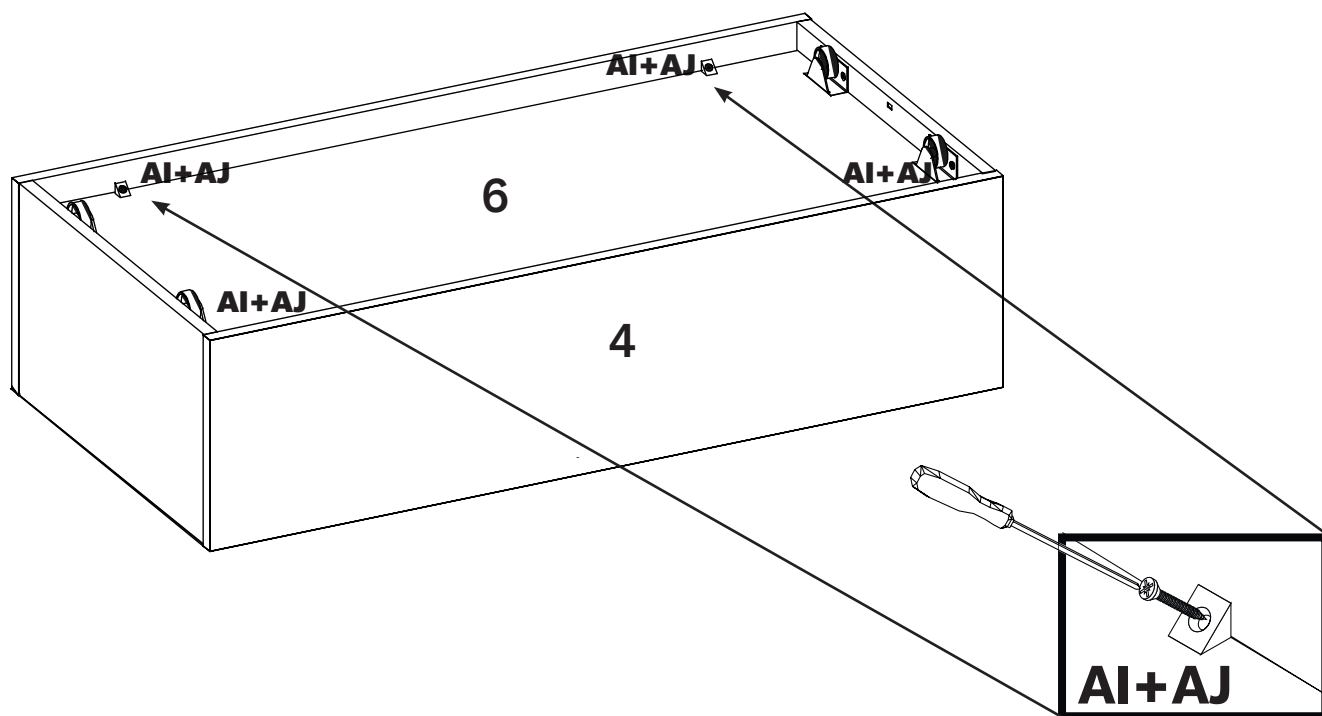
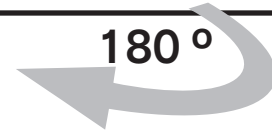

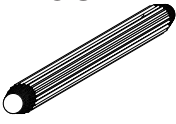
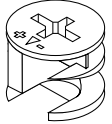
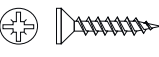
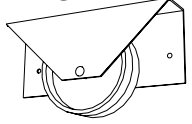
77	C x 08 	F x 08 	G x 08  3.5 x 15 mm.	AC x 04 
----	---	---	---	--

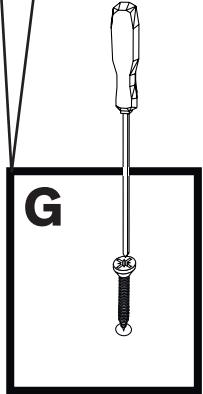
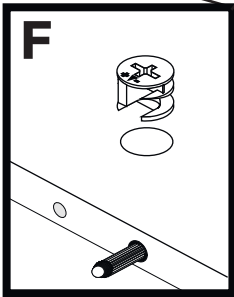
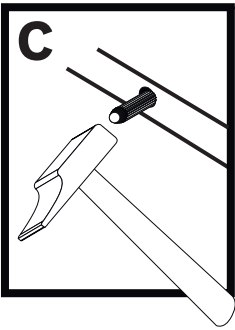
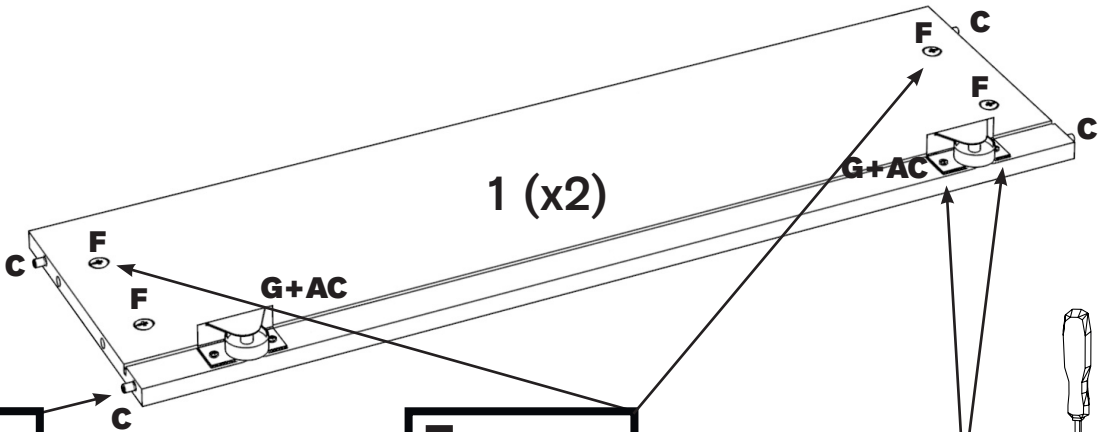

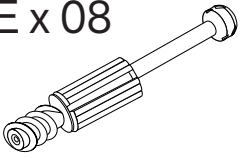
78	E x 08 
----	---

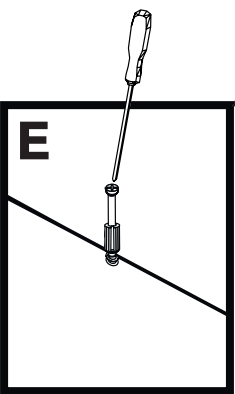
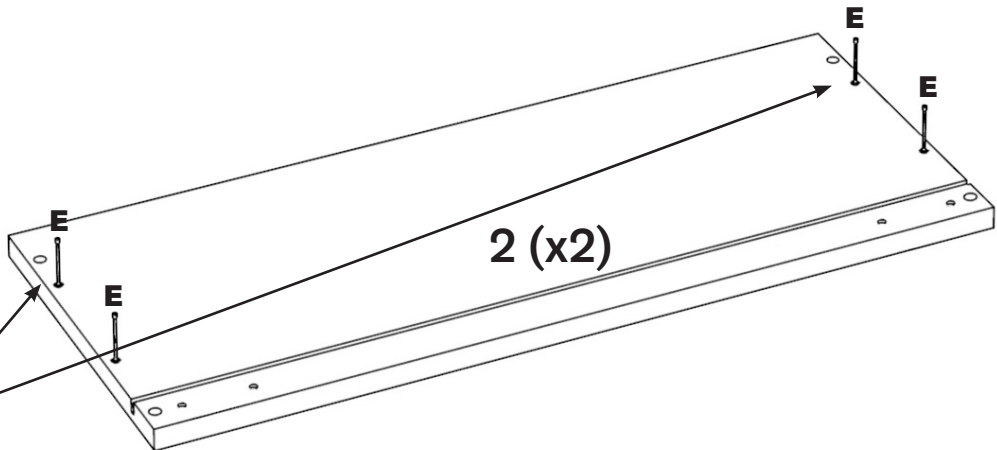

**79** AE x 01  
 N° 4

AG x 08  
 17 mm.

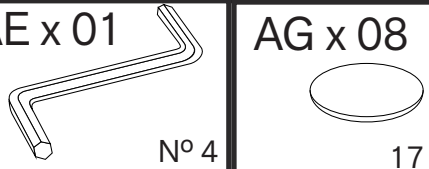
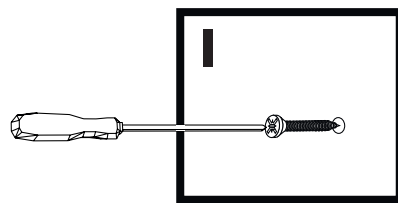
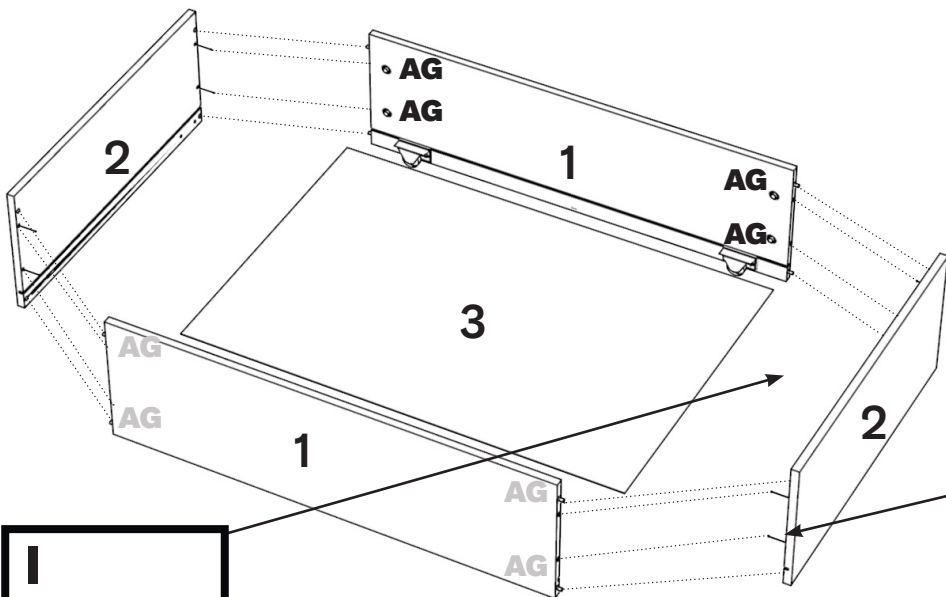
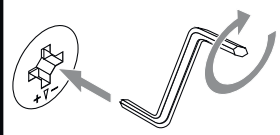



**AE+AG**

**80** AI x 04

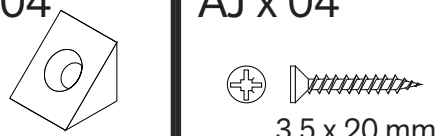
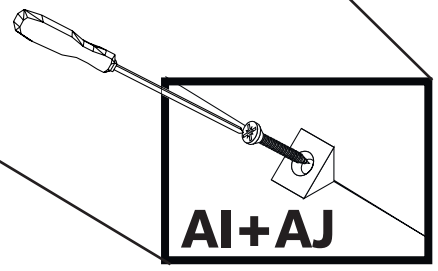
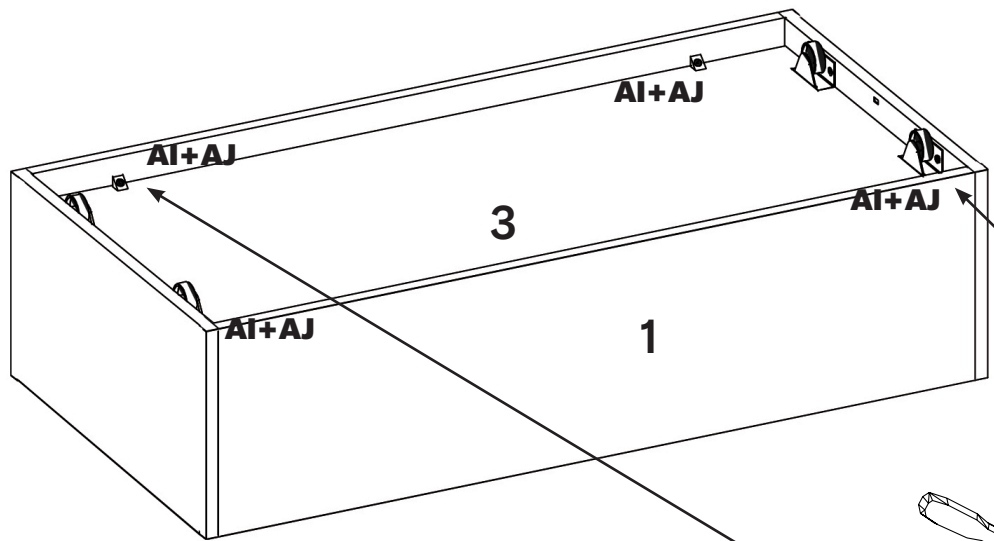
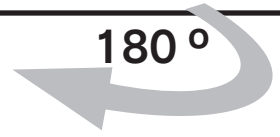
AJ x 04  
 3.5 x 20 mm.

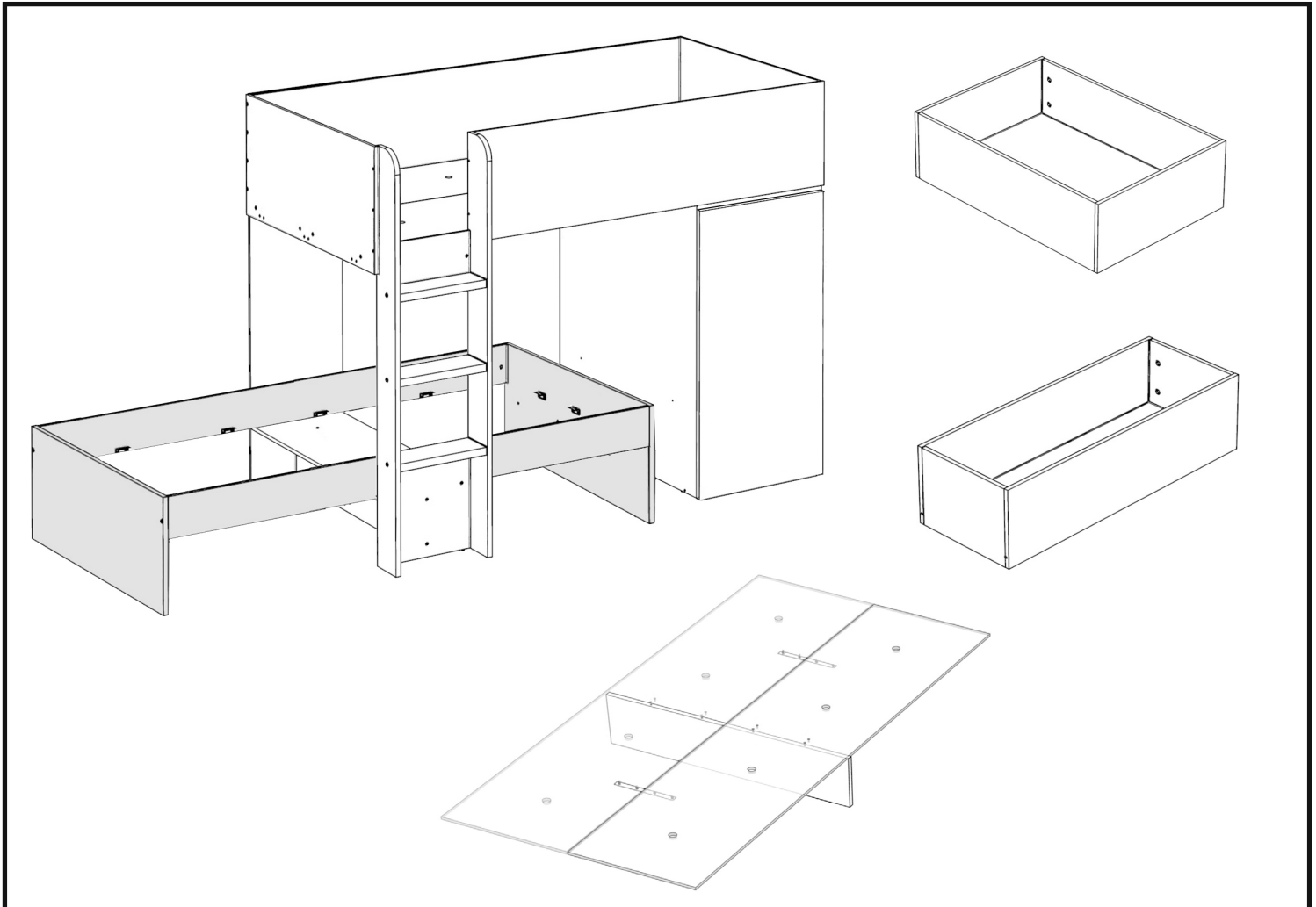



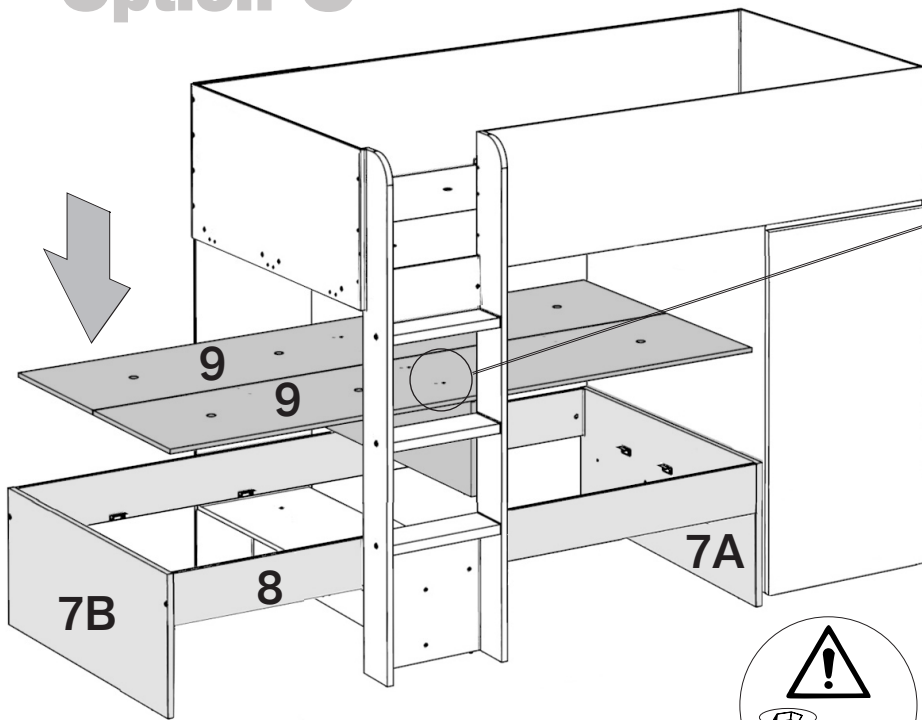

**81** **Option C**

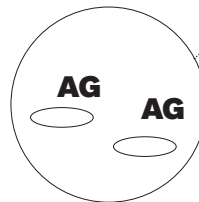
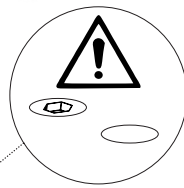
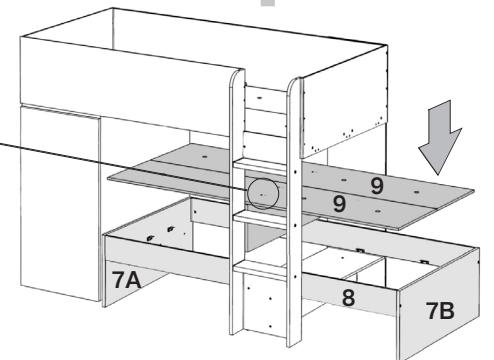

**Option D**



82 J x 03

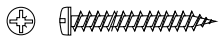

4 x 30 mm.

# Option C

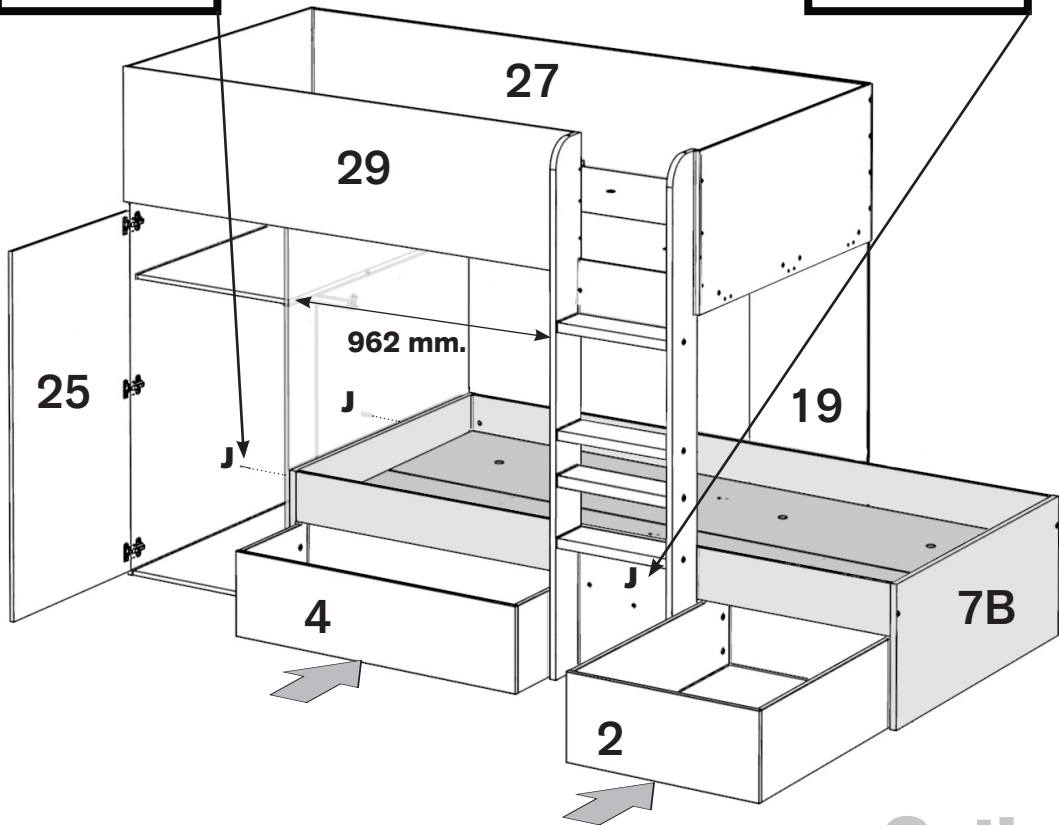
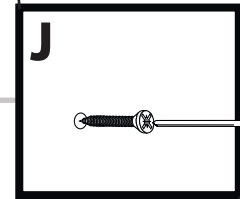
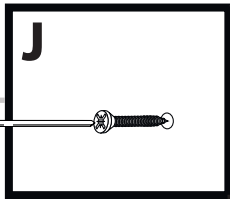
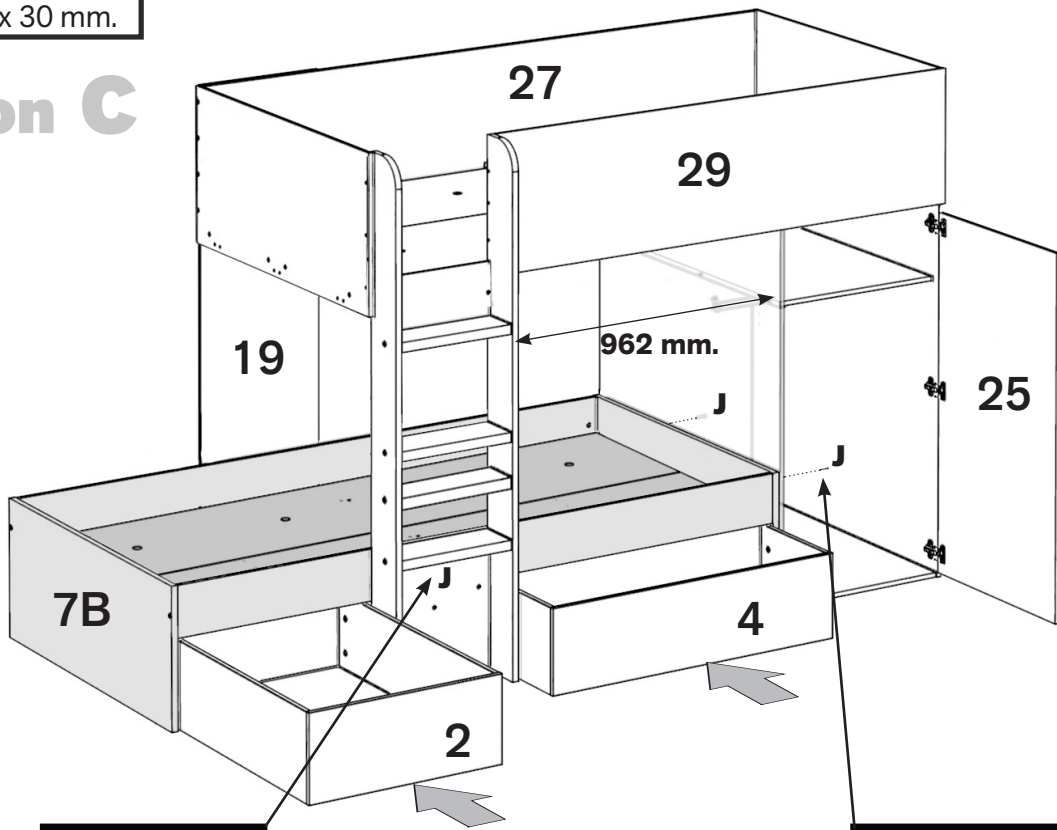

# Option D