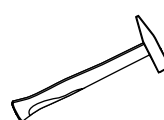
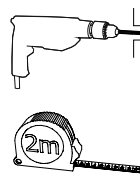
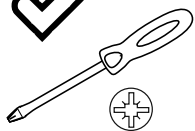
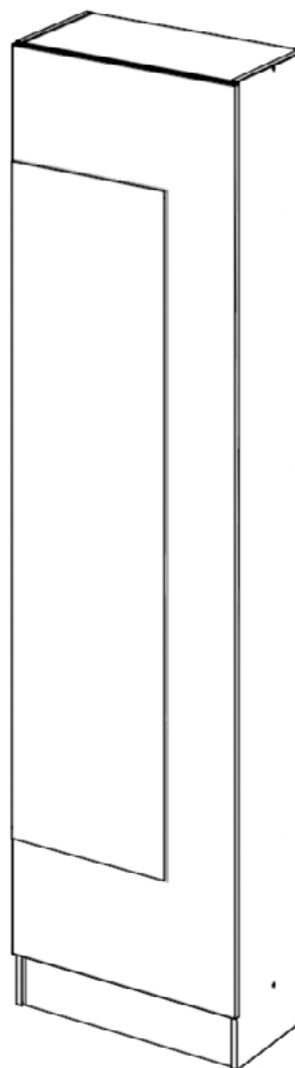
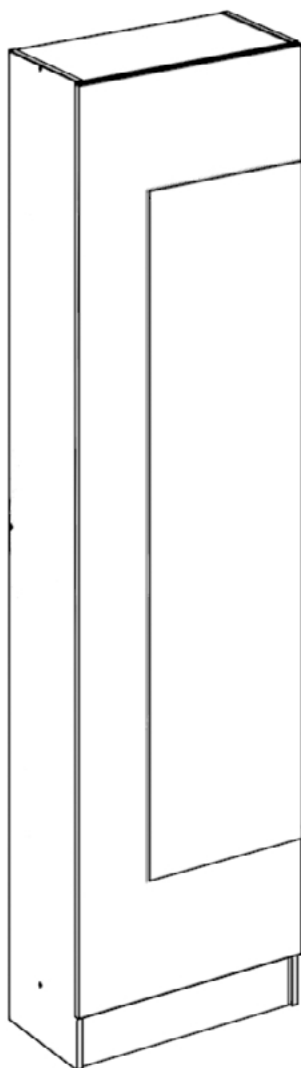

DEKIT®**K459** v.01**1.5 h.****ES****RECOMENDACIONES
MONTAJE Y USO**

Agrupe y cuente el herraje.
Prepare todas las piezas para el montaje del mueble.
Tenga preparadas las herramientas para el montaje.
Prepare la zona del montaje.
Monte el mueble sobre una moqueta para evitar rayar y dañar la superficie del mueble.
No fuerce los ensamblajes.
Evite colocar el mueble cerca de fuentes de calor.
Evite utilizar trapos, paños o productos de limpieza que puedan dañar la superficie del mueble.
Mueble para uso doméstico en interior de vivienda.

EN**RECOMENDATIONS
FOR ASSEMBLY AND USE**

Prepare all the parts of the furniture
Group and count all the hardware
Prepare all the tools for the assembly.
Clear and prepare the assembly area.
Do the assembly on a carpet to avoid damaging the surface of the furniture
Avoid forcing the fittings
Avoid placing the Furniture near any heating source
Do not use cloths or cleaning products to avoid damaging the surface of the furniture
Indoor furniture. Suitable for domestic use.

FR**CONSEILS DE MONTAGE
CONSEILS POUR L'USAGE**

Préparez les différents parts du meuble
Regrouper et compter toute la quincaillerie
Préparez l'outillage nécessaire
Aménagez-vous une area de montage
Faire le montage sur moquette afin de protéger le meuble des rayures
Ne forcer pas le montage
Évitez placer le meuble près des sources de chaleur
Évitez utiliser de chiffons ou des produits de nettoyage pour ne pas rayer la superficie du meuble
Meuble d'usage domestique pour l'intérieur de la maison.

PT**RECOMENDAÇÕES
PARA MONTAGEM E USO**

Prepare todas as peças para a montagem de móveis
Reagrupar e contar o hardware
Preparar as ferramentas de montagem
Preparar a área de montagem
Montar as peças em tapete para evitar riscos e danos na superfície dos móveis
Não force as assembleias
Não colocar móveis perto de fontes de calor
Evitar o uso de panos, trapos ou produtos de limpeza que possam riscar o móvel.
Móveis para uso doméstico no interior da casa.

**FR**
**DONNEZ
OU
RECYCLEZ**

ASSOCIATION



MAGASIN



DÉCHÈTERIE

Adresses sur quefairedemesdechets.fr**IT****CONSIGLI INSTALLAZIONE ED USO**

Preparare tutti componenti del mobile per il montaggio
Ordinare la ferramenta
Preparare tutti gli attrezzi necessari per il montaggio
Preparare l'area di montaggio
Fare il montaggio su un tappeto per evitare danneggiare le superfici dei mobili
Non forzare i componenti
Evitare posizionare il mobile in prossimità di fonti di calore
Non usare panni né detersivi né solventi che possano danneggiare le superfici dei mobili
Mobili per uso domestico all'interno della casa.

DE**MONTAGEHINWEISE-GEBRAUCHSHINWEISE**

Identifizieren Sie die Einzelteile
Überprüfen Sie Die Anzahl der einzelnen Beschlagteile
Legen Sie das notwendige Werkzeug bereit
Bereiten die Montagefläche
Montieren Sie das Möbel auf einem Teppich , sauberen Untergrund
Niemals die verbindungen zu start anziehen
Nicht neben Wärmequellen platzieren
Vermeiden Sie Tücher und keinesfalls scharfe oder ätzende Reinigungsmittel.
Möbel für den Gebrauch im Haus geeignet.

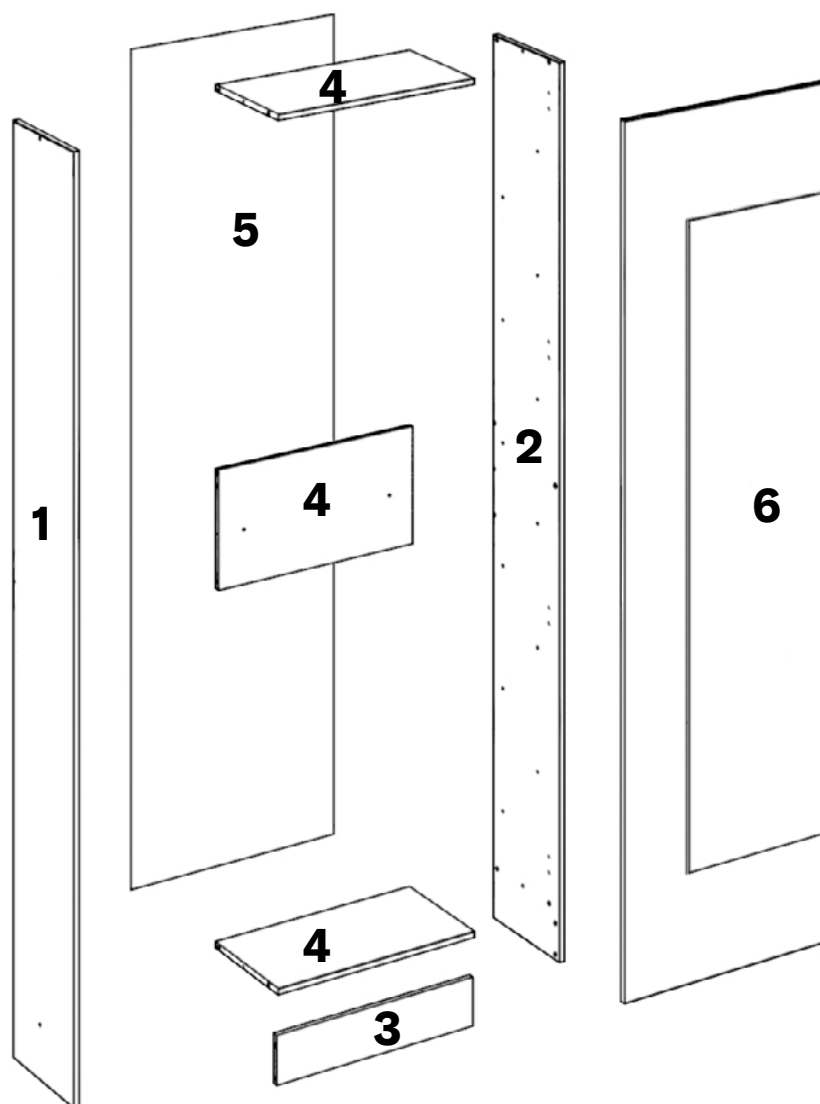
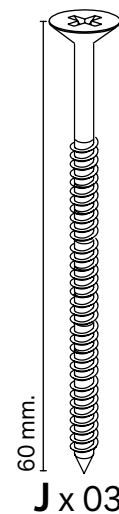
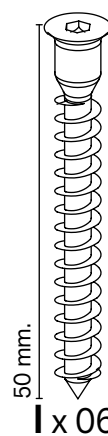
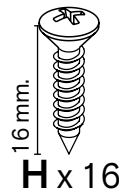
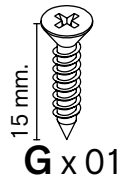
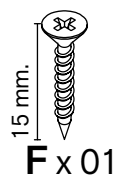
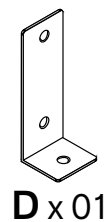
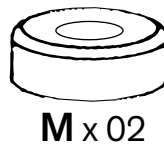
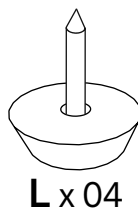
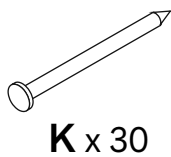
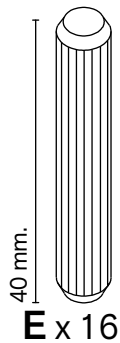
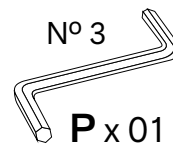
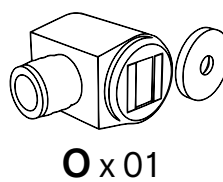
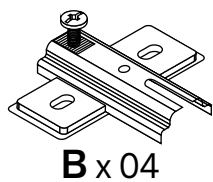
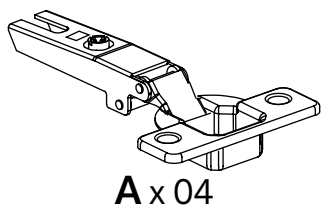

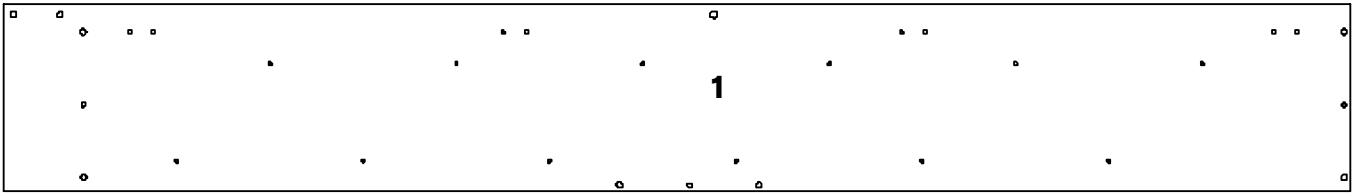

1850 x 247 mm.

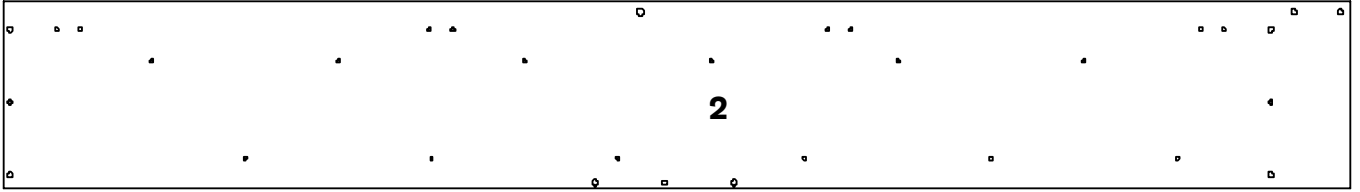

1850 x 247 mm.



470 x 102 mm.

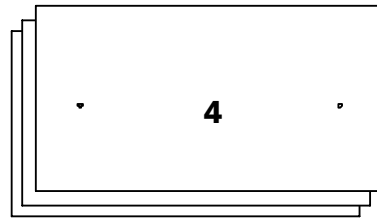

470 x 246 mm.

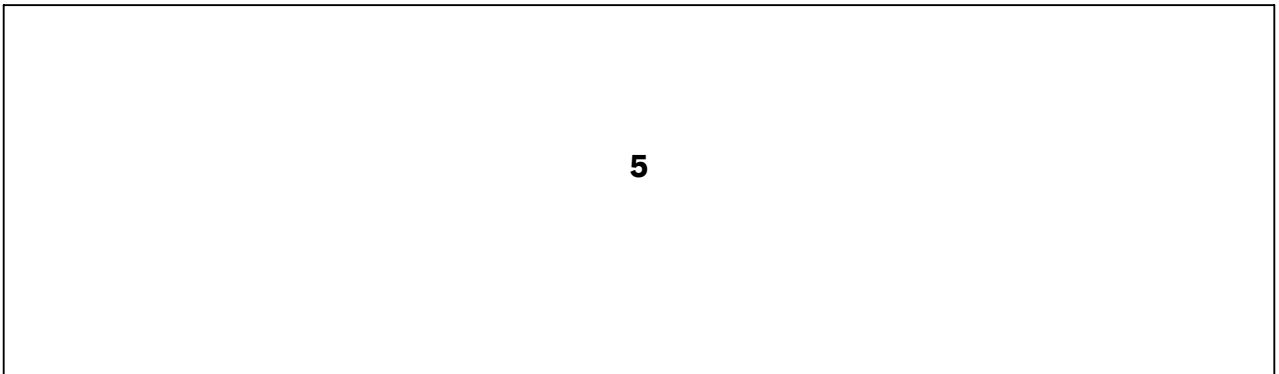

1745 x 500 mm.

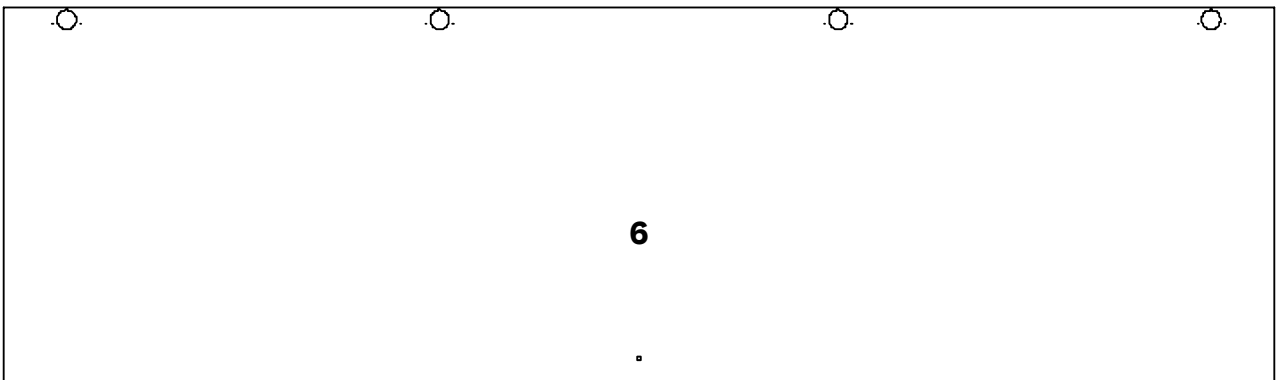

1745 x 507 mm.

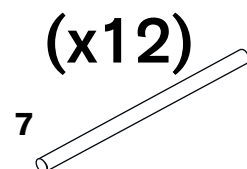

1

40 mm.

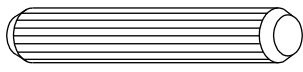

E x 04

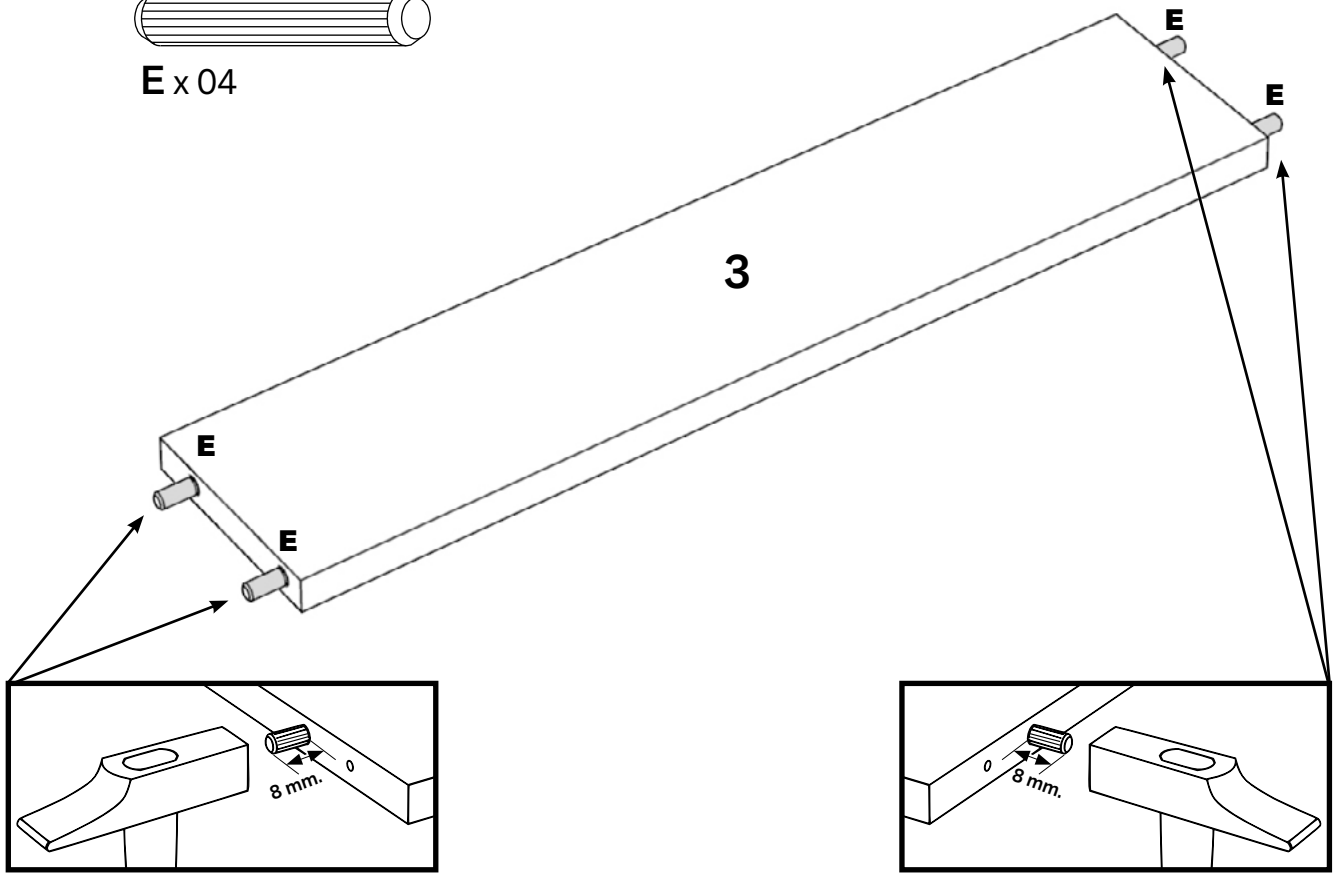

2

40 mm.

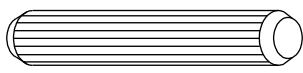

E x 12

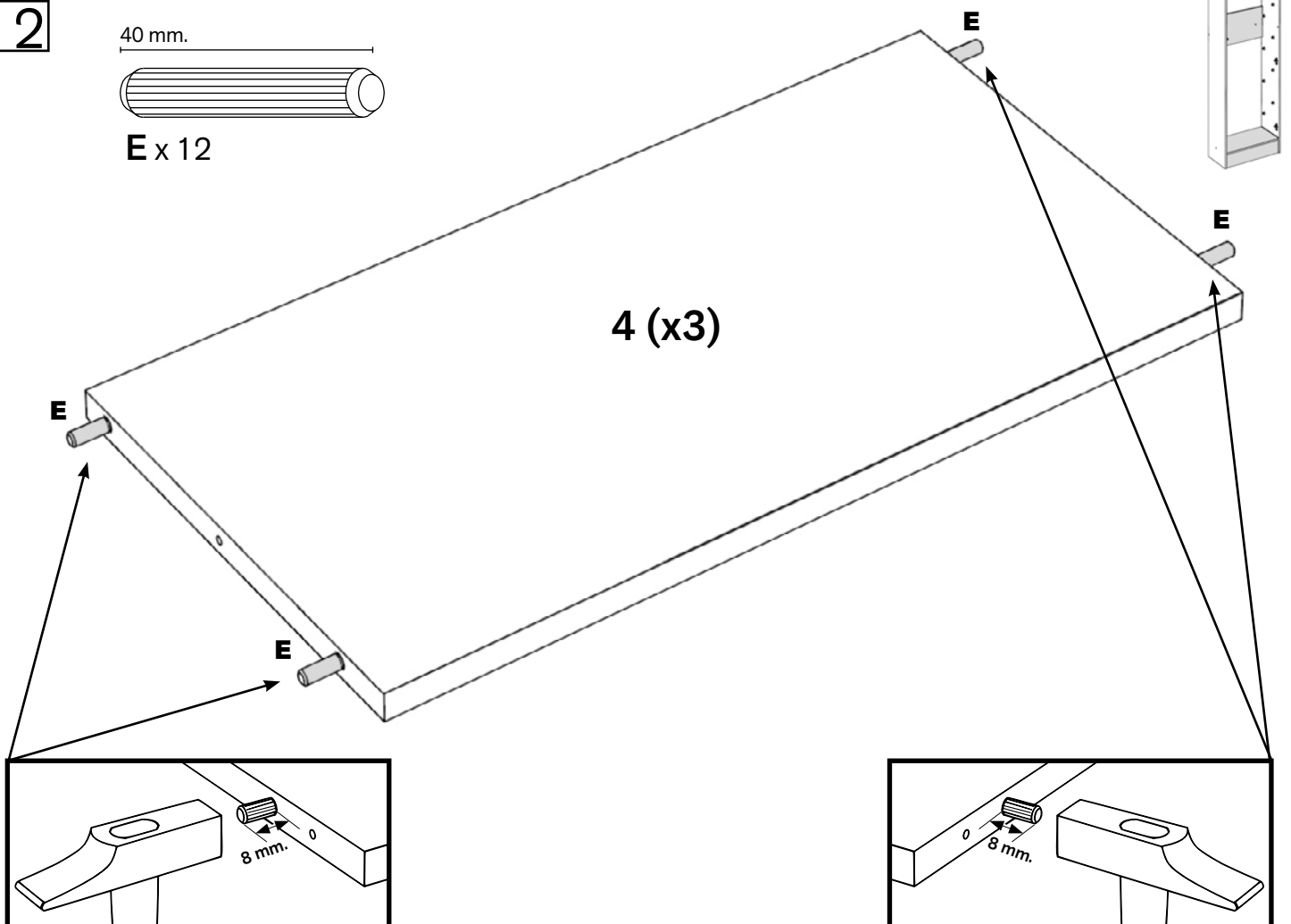

3

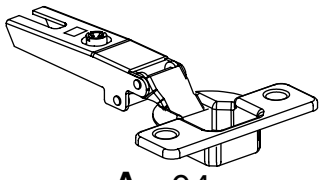

A x 04

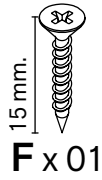

15 mm.
F x 01



15 mm.
~~G~~

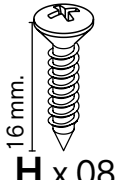

16 mm.
H x 08

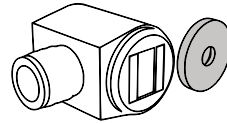

O x 01

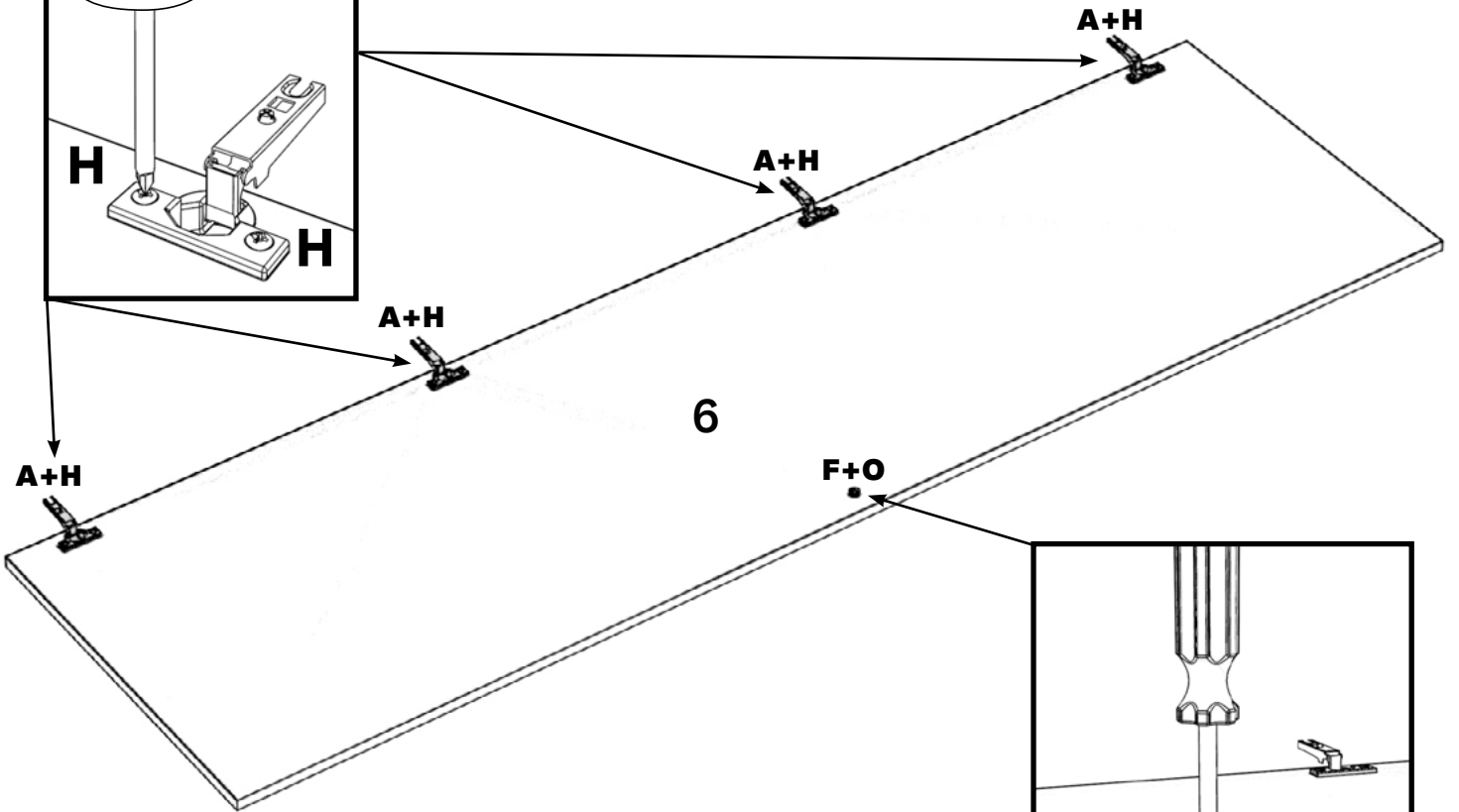
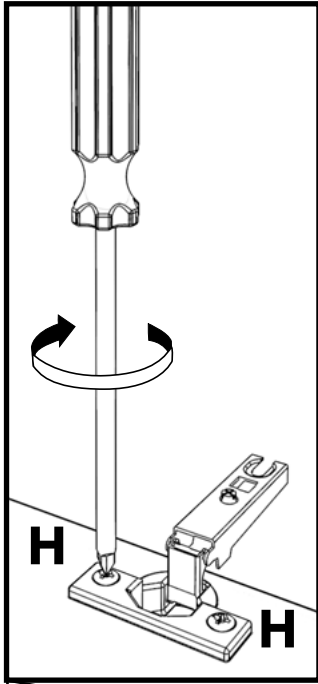

6

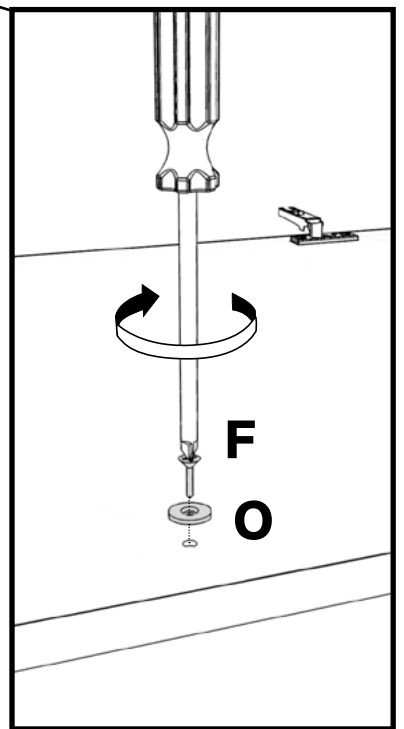

Option A

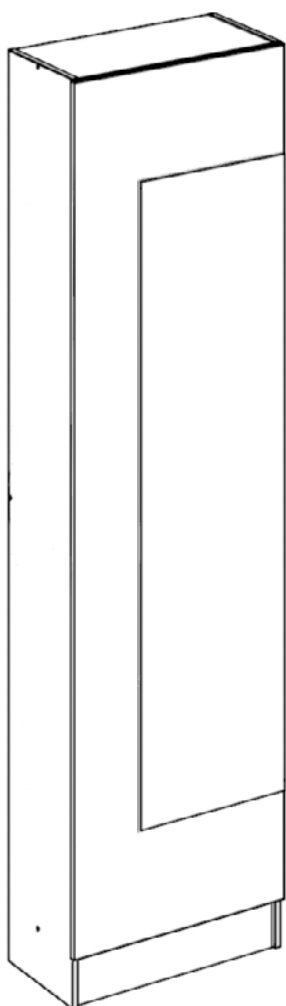

Pág. 7 - 12

Option B

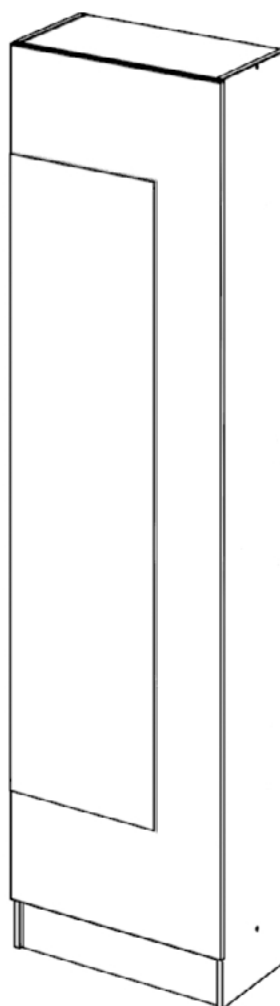

Pág. 13 - 19

5

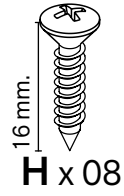
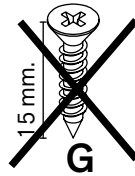
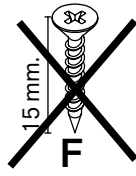
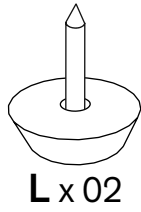
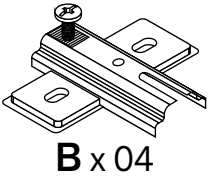

Option A

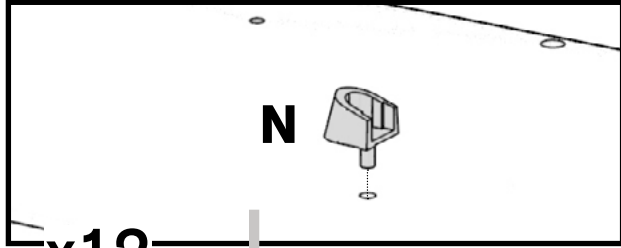
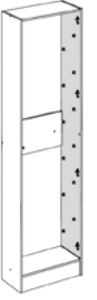

x12

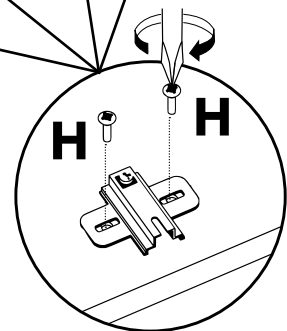
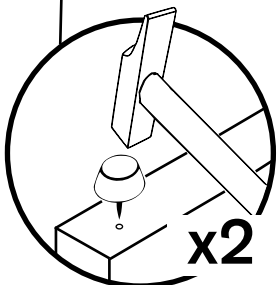
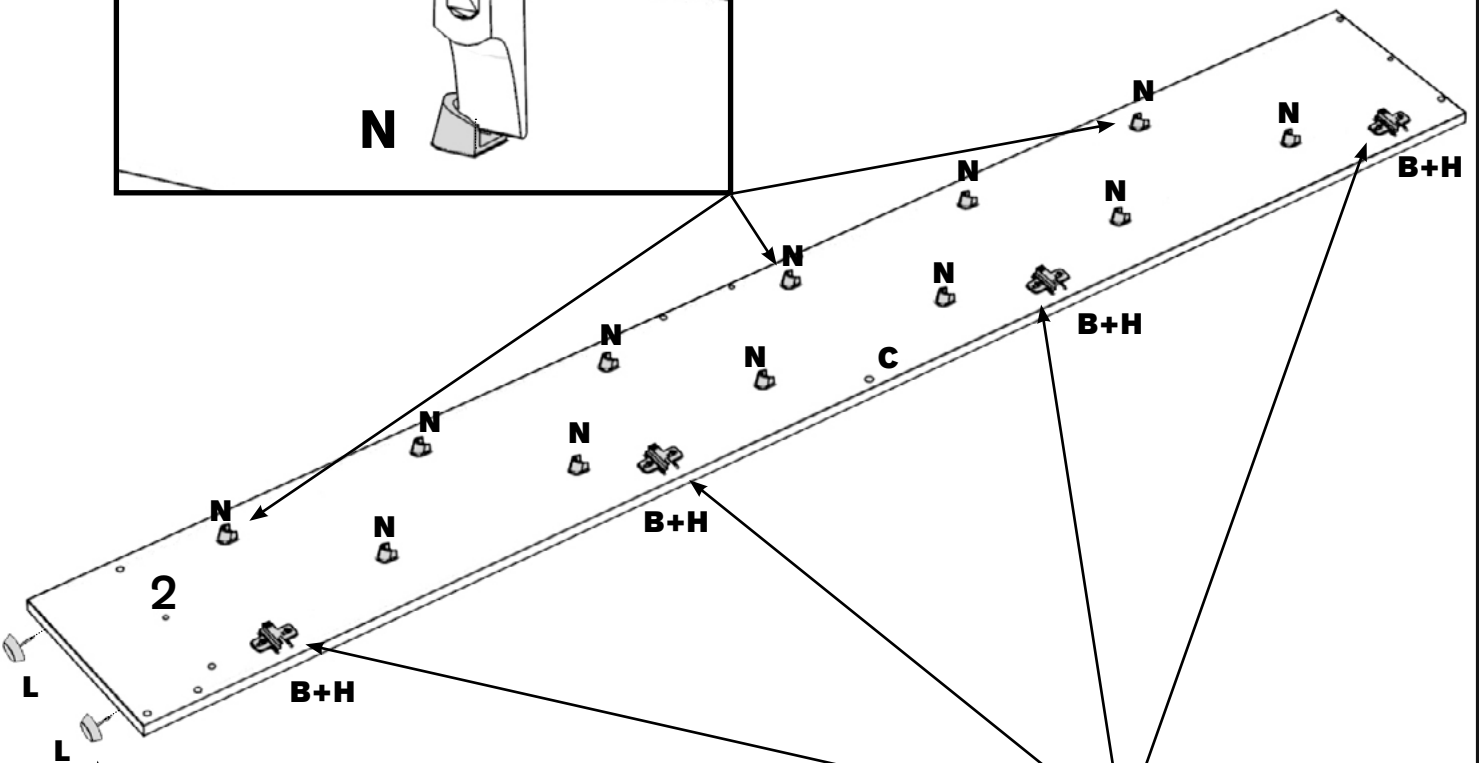
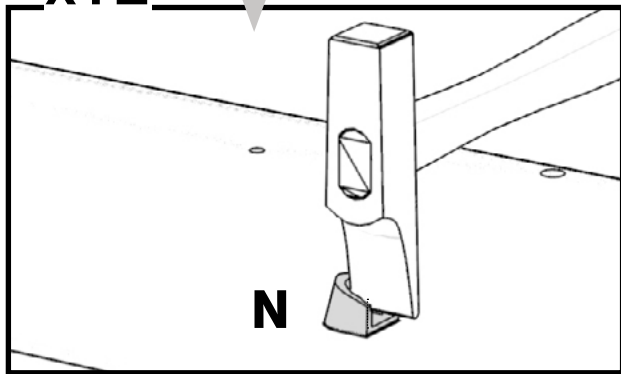

6

13 mm.
C x 06

50 mm.

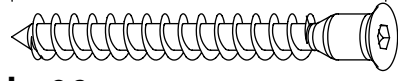

I x 06

Option A

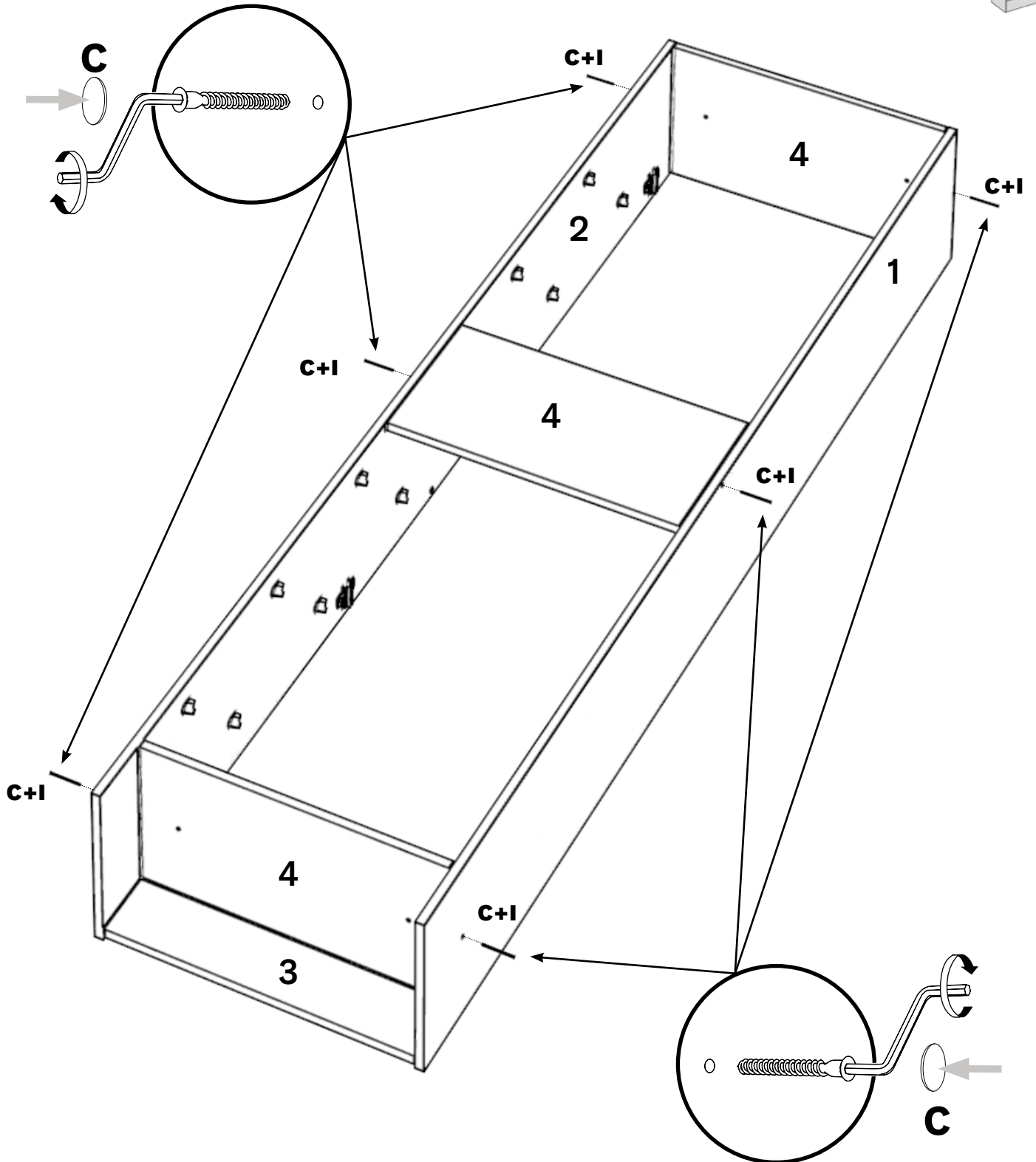
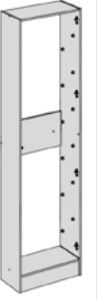

7

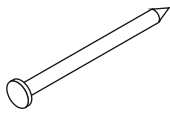

K x 30

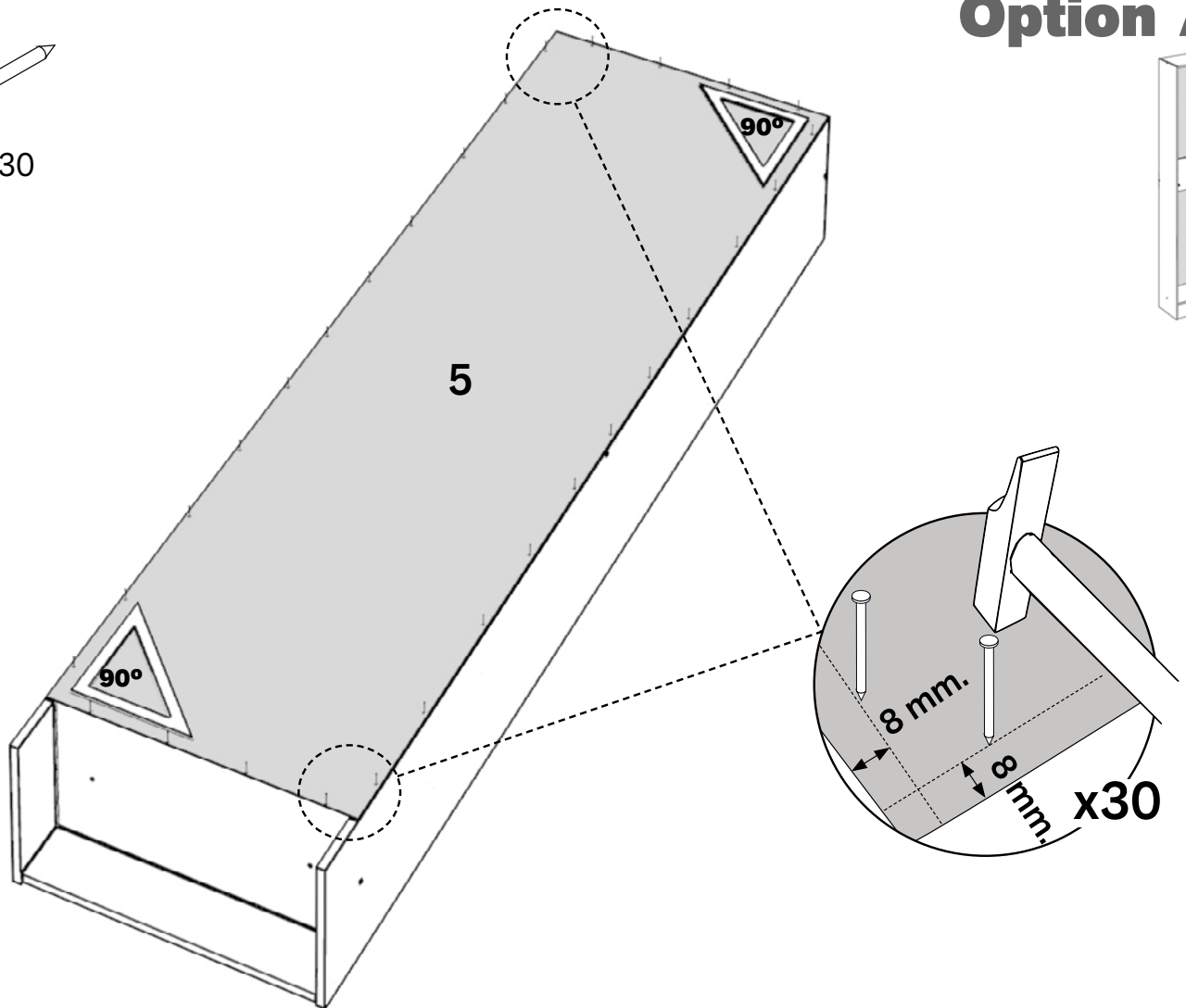

Option A

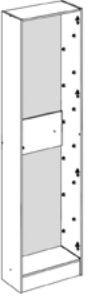

Español

Atención !!!

Antes de fijar el mueble a la pared compruebe su resistencia y naturaleza. En caso de que se suministren tacos y tornillos con el producto, éstos se destinan únicamente a los muros hechos con materiales sólidos y homogéneos. En caso de duda, consulte a un especialista, debiendo efectuar este montaje un operario especializado.

ADVERTENCIA: Con el fin de evitar la caída/vuelco, este mueble debe utilizarse siempre con el dispositivo de fijación de pared suministrado. Pueden producirse lesiones graves o fatales si vuelca un mueble. Para evitar que vuelque este mueble, debe fijarse permanentemente a la pared.

Français

Attention!!!

Avant de suspendre le meuble ou de le fixer au mur, vérifiez au préalable le type et la résistance du mur. Utilisez les chevilles et les vis adaptées au type de mur. En cas de doute, consultez un spécialiste et un opérateur spécialisé doit effectuer cet assemblage.

AVERTISSEMENT: Risque de blessure grave en cas de chute du meuble. Pour éviter que ce meuble ne bascule, il faut le fixer au mur de façon permanente.

English

Warning !!!

Before suspending or fixing to the wall check the type and strength of the wall. If the screws and dowels are supplied with the product, these are only intended for walls made of solid and homogeneous materials. In the case of doubts, contact a specialist, the installation must be performed by a competent person.

WARNING: Serious or fatal crushing injuries can occur from furniture tip-over. To prevent this furniture from tipping over, it must be permanently fixed to the wall.

Italiano

Attenzione!!!

Prima di fissare i mobili al muro, verifica prima la tipologia e resistenza del muro. Se viti e tasselli sono inclusi nell'offerta, essi sono utilizzabili solamente per i muri fatti di un certo tipo di materiale.

AVVERTENZA: Se il mobile si ribalta può causare lesioni da compressione serie o fatali. Per prevenire il rischio che il mobile si ribalti, quest'ultimo deve essere fissato permanentemente alla parete. Gli accessori per il fissaggio alla parete non sono inclusi perché pareti di materiali diversi richiedono tipi diversi di accessori di fissaggio. Usa sistemi di fissaggio adatti alle pareti della tua casa. Per maggiori dettagli, rivolgiti a un rivenditore specializzato.

Deutsch

Achtung!!!

Bevor Sie die Möbel an der Wand befestigen, überprüfen Sie deren Festigkeit und Beschaffenheit. Falls Dübel und Schrauben im Lieferumfang des Produkts enthalten sind, sind diese nur für Wände aus festen und homogenen Materialien vorgesehen. Wenden Sie sich im Zweifelsfall an einen Fachmann, und ein Fachmann muss diese Montage durchführen.

WARNUNG: Wenn Möbelstücke umkippen, können ernste oder lebensgefährliche Verletzungen durch Einklemmen die Folge sein. Um zu verhindern, dass das Möbelstück umkippt, muss es fest an der Wand verankert werden.

Português

Atenção!!!

Antes de pendurar ou fixar o móvel na parede, verifique com antecedência a sua natureza e resistência. Se o produto for acompanhado de buchas e parafusos, estes destinam-se só às paredes feitas com materiais sólidos e homogéneos. Em caso de dúvida, consulte um especialista. A montagem deve ser efetuado por uma pessoa competente.

IMPORTANTE: As quedas de móveis podem originar esmagamento ou morte. Estes móveis devem ser fixados à parede para evitar possíveis quedas.

8

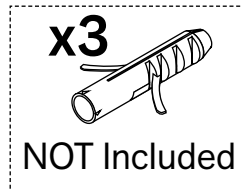
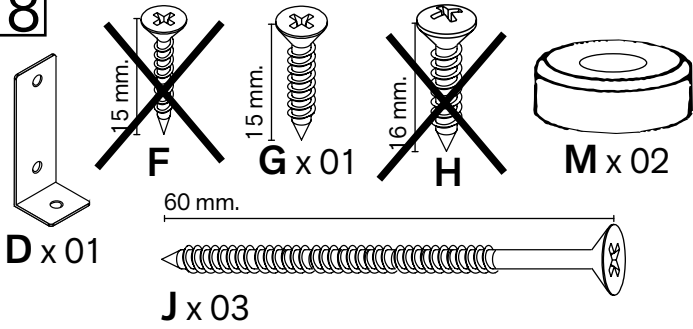
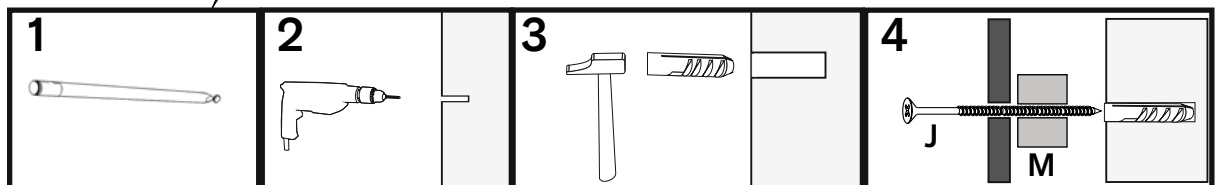
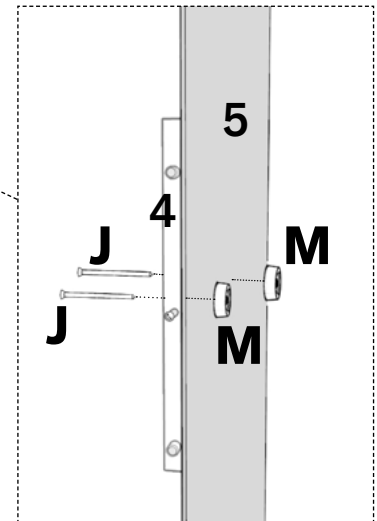
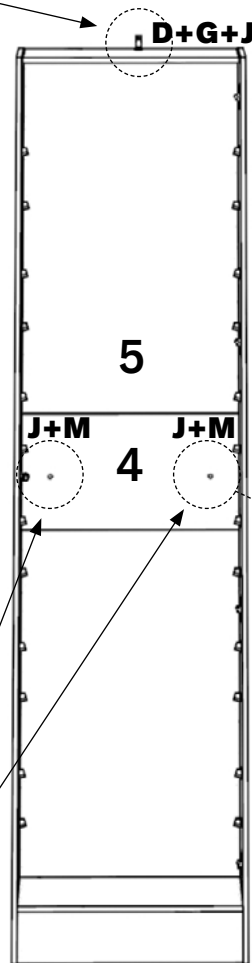
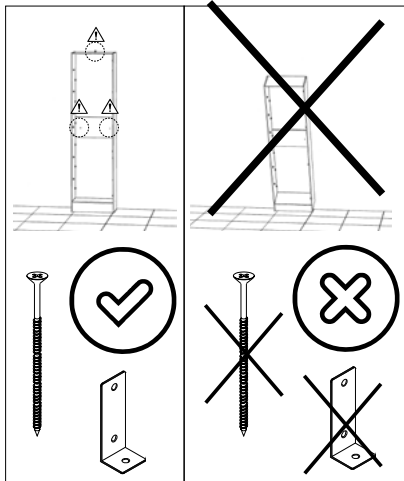
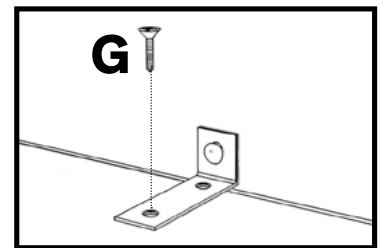
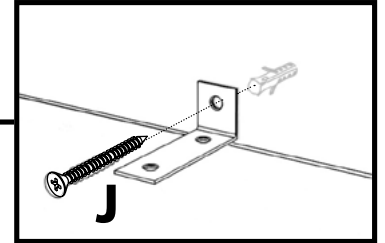
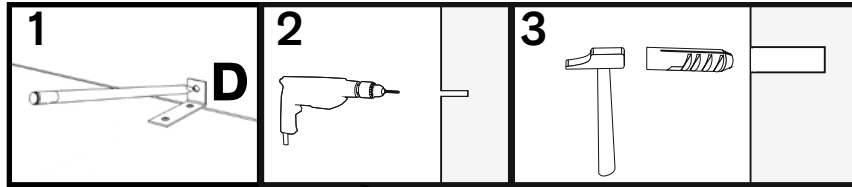
**Option A****EN**

For your safety always fix the furniture to the wall. Use wall plugs and screws appropriate for your type of wall.

ES

Por su seguridad fijar siempre el mueble a la pared. Use tacos y tornillos adecuados para su tipo de pared.

FR

Pour votre sécurité, fixez toujours les meubles au mur. Utilisez des chevilles et des vis adaptées à votre type de mur.

PT

Para sua segurança, prenda sempre os móveis à parede. Use buchas e parafusos adequados para o seu tipo de parede.

IT

Per la tua sicurezza fissa sempre i mobili al muro. Utilizzare tasselli e viti appropriati per il tipo di muro.

DE

Befestigen Sie die Möbel zu Ihrer Sicherheit immer an der Wand. Verwenden Sie für den Wandtyp geeignete Anker und Schrauben.

9

Option A

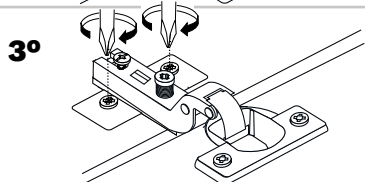
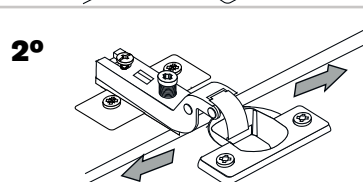
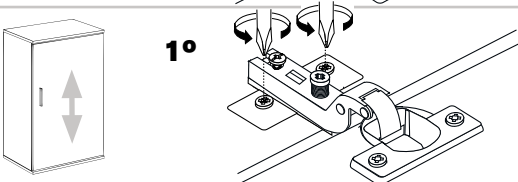
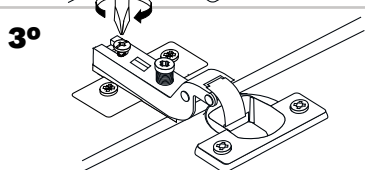
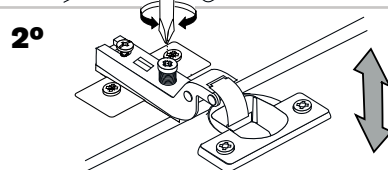
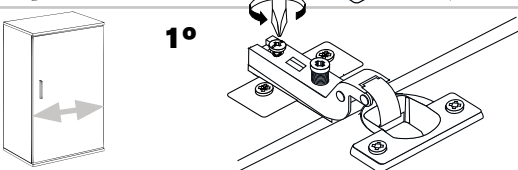
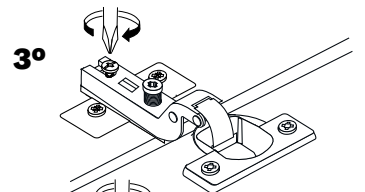
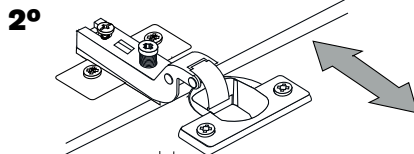
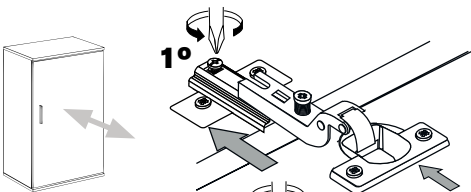
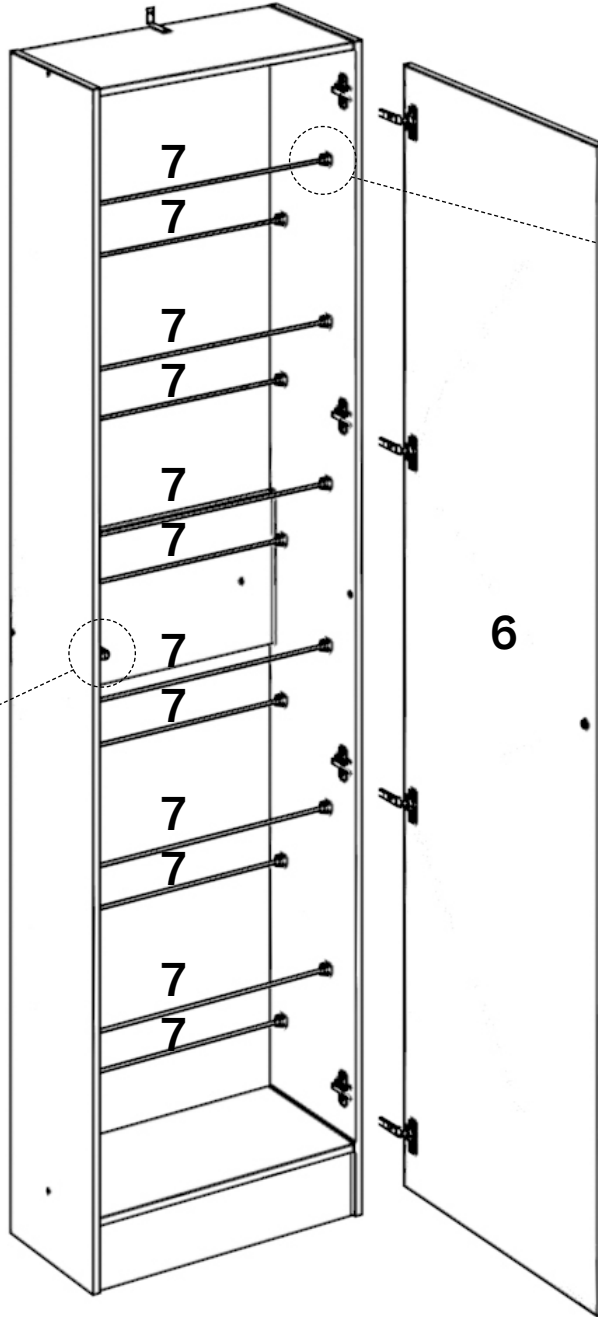
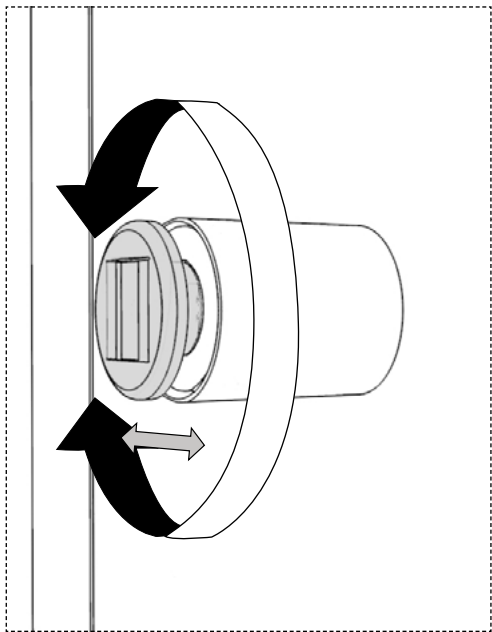

Option B

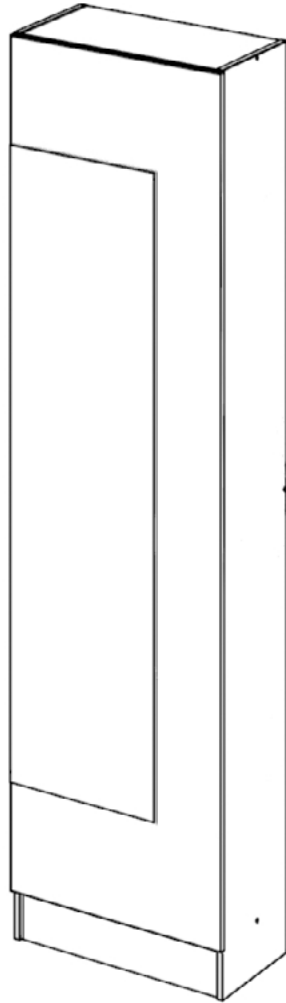

Pág. 13 - 19

4

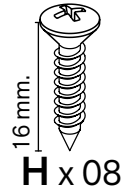
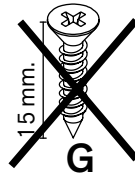
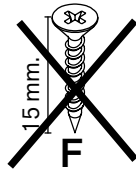
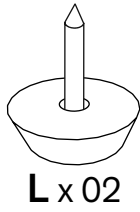
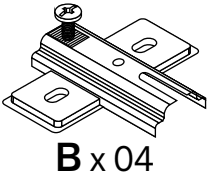

Option B

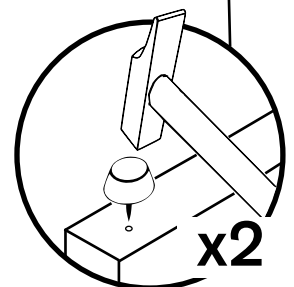
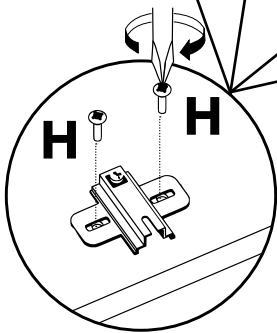
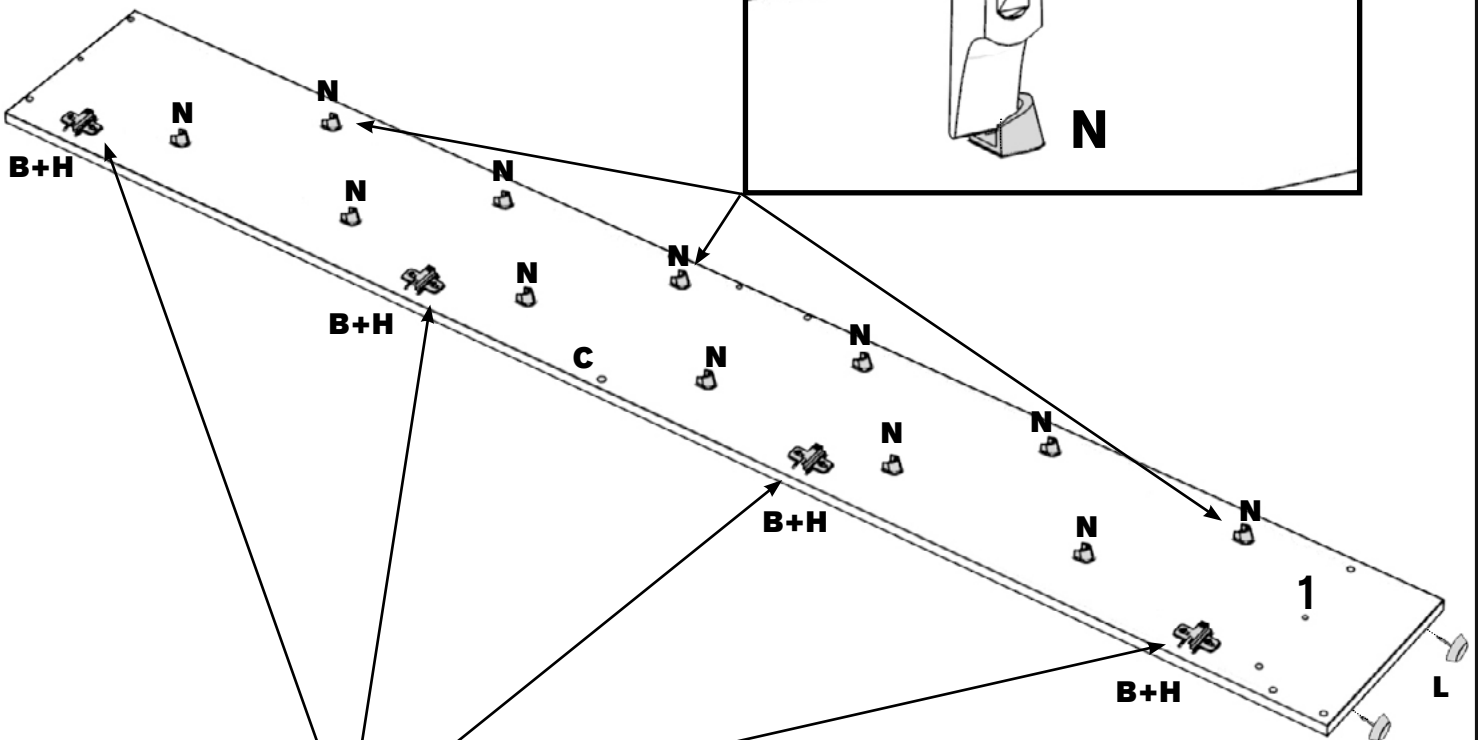
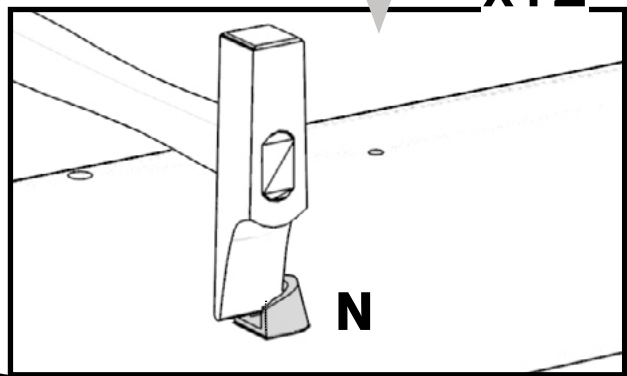
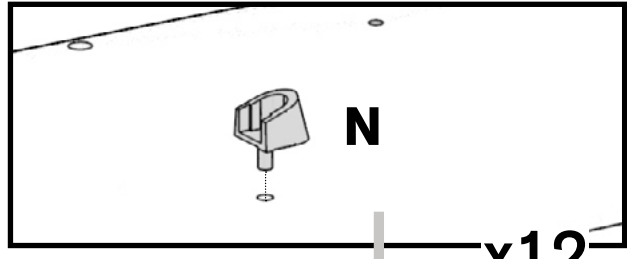
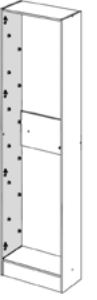

5

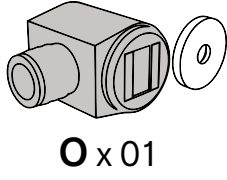
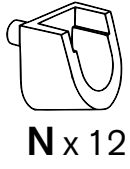
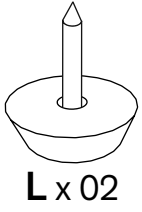

Option B

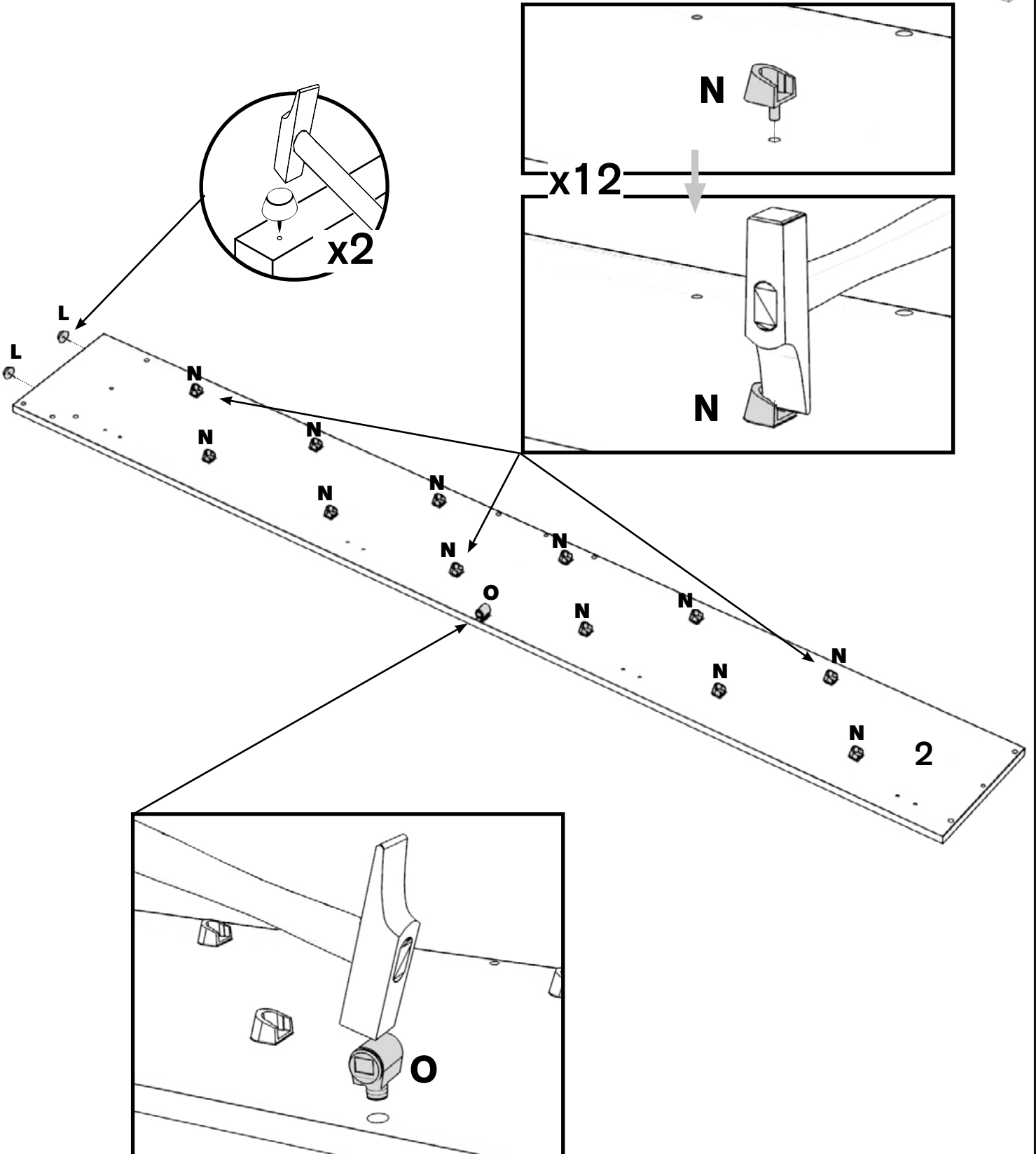
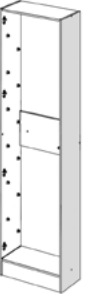

6

13 mm.
C x 06

50 mm.
I x 06

Option B

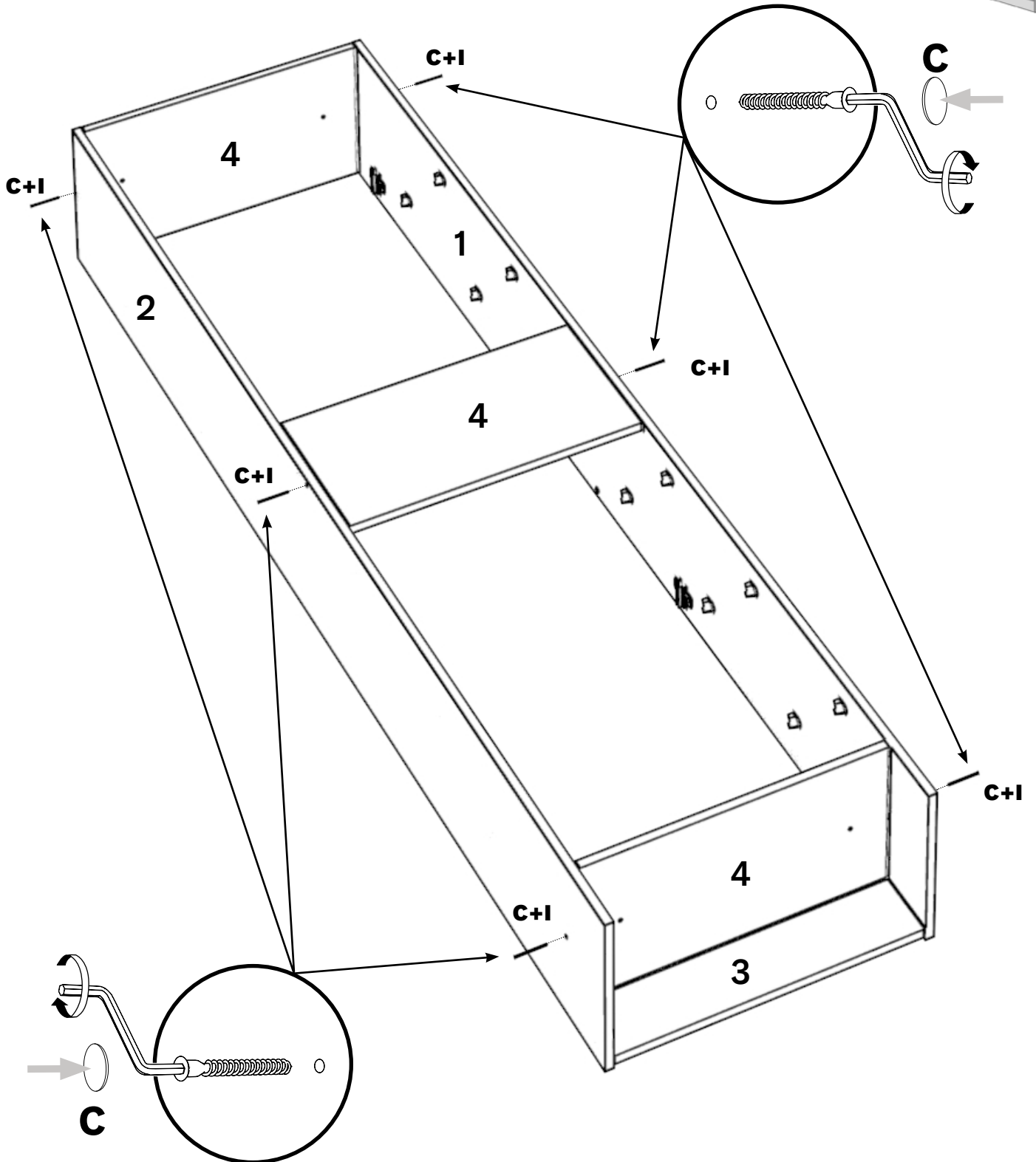
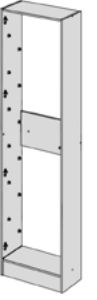

7

Option B

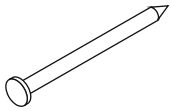

K x 30

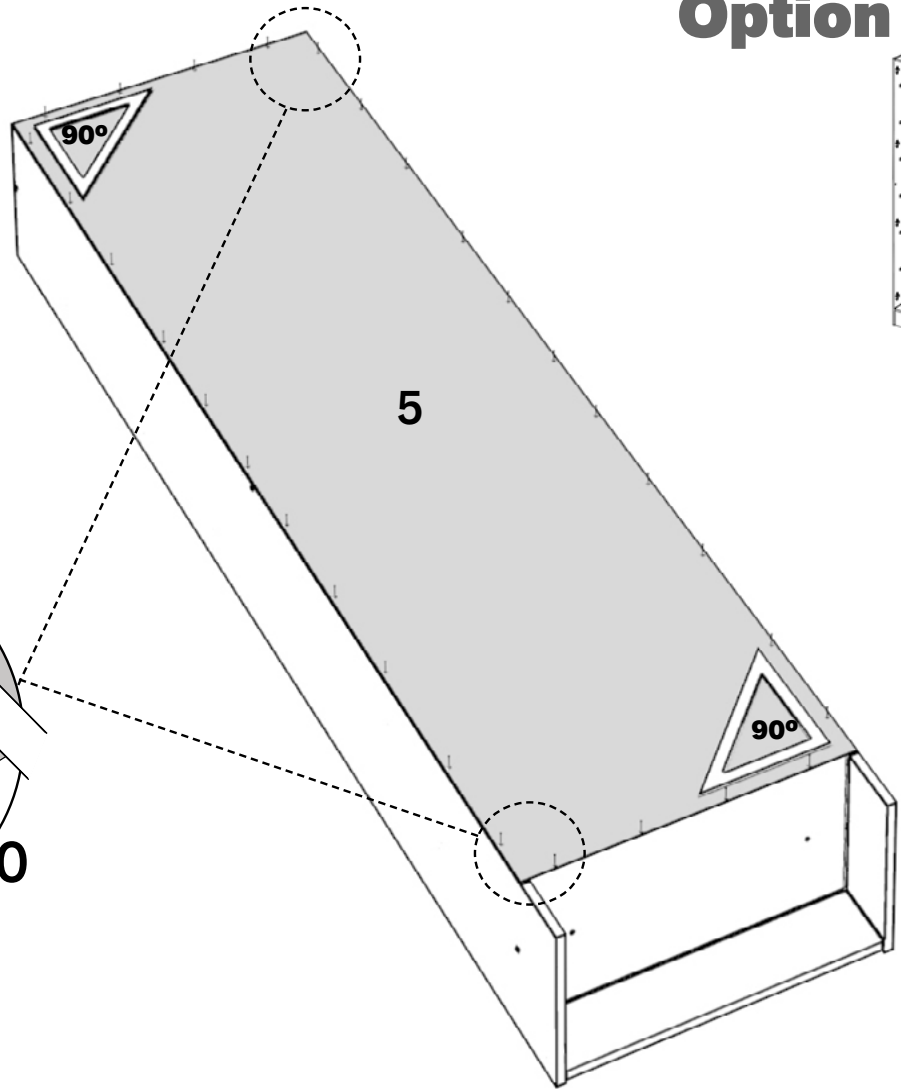
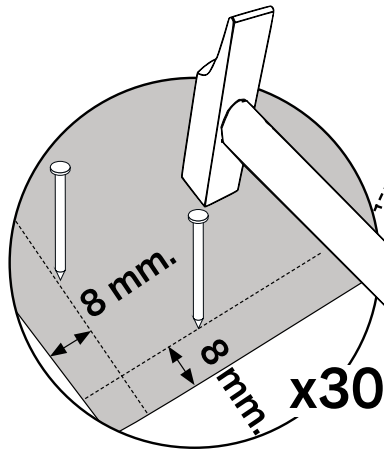

Español

Atención !!!

Antes de fijar el mueble a la pared compruebe su resistencia y naturaleza. En caso de que se suministren tacos y tornillos con el producto, éstos se destinan únicamente a los muros hechos con materiales sólidos y homogéneos. En caso de duda, consulte a un especialista, debiendo efectuar este montaje un operario especializado.

ADVERTENCIA: Con el fin de evitar la caída/vuelco, este mueble debe utilizarse siempre con el dispositivo de fijación de pared suministrado. Pueden producirse lesiones graves o fatales si vuelca un mueble. Para evitar que vuelque este mueble, debe fijarse permanentemente a la pared.

Français

Attention!!!

Avant de suspendre le meuble ou de le fixer au mur, vérifiez au préalable le type et la résistance du mur. Utilisez les chevilles et les vis adaptées au type de mur. En cas de doute, consultez un spécialiste et un opérateur spécialisé doit effectuer cet assemblage.

AVERTISSEMENT: Risque de blessure grave en cas de chute du meuble. Pour éviter que ce meuble ne bascule, il faut le fixer au mur de façon permanente.

English

Warning !!!

Before suspending or fixing to the wall check the type and strength of the wall. If the screws and dowels are supplied with the product, these are only intended for walls made of solid and homogeneous materials. In the case of doubts, contact a specialist, the installation must be performed by a competent person.

WARNING: Serious or fatal crushing injuries can occur from furniture tip-over. To prevent this furniture from tipping over, it must be permanently fixed to the wall.

Italiano

Attenzione!!!

Prima di fissare i mobili al muro, verifica prima la tipologia e resistenza del muro. Se viti e tasselli sono inclusi nell'offerta, essi sono utilizzabili solamente per i muri fatti di un certo tipo di materiale.

AVVERTENZA: Se il mobile si ribalta può causare lesioni da compressione serie o fatali. Per prevenire il rischio che il mobile si ribalti, quest'ultimo deve essere fissato permanentemente alla parete. Gli accessori per il fissaggio alla parete non sono inclusi perché pareti di materiali diversi richiedono tipi diversi di accessori di fissaggio. Usa sistemi di fissaggio adatti alle pareti della tua casa. Per maggiori dettagli, rivolgiti a un rivenditore specializzato.

Deutsch

Achtung!!!

Bevor Sie die Möbel an der Wand befestigen, überprüfen Sie deren Festigkeit und Beschaffenheit. Falls Dübel und Schrauben im Lieferumfang des Produkts enthalten sind, sind diese nur für Wände aus festen und homogenen Materialien vorgesehen. Wenden Sie sich im Zweifelsfall an einen Fachmann, und ein Fachmann muss diese Montage durchführen.

WARNUNG: Wenn Möbelstücke umkippen, können ernste oder lebensgefährliche Verletzungen durch Einklemmen die Folge sein. Um zu verhindern, dass das Möbelstück umkippt, muss es fest an der Wand verankert werden.

Português

Atenção!!!

Antes de pendurar ou fixar o móvel na parede, verifique com antecedência a sua natureza e resistência. Se o produto for acompanhado de buchas e parafusos, estes destinam-se só às paredes feitas com materiais sólidos e homogéneos. Em caso de dúvida, consulte um especialista. A montagem deve ser efetuado por uma pessoa competente.

IMPORTANTE: As quedas de móveis podem originar esmagamento ou morte. Estes móveis devem ser fixados à parede para evitar possíveis quedas.

8

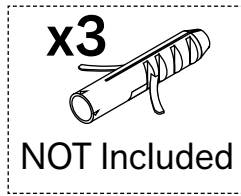
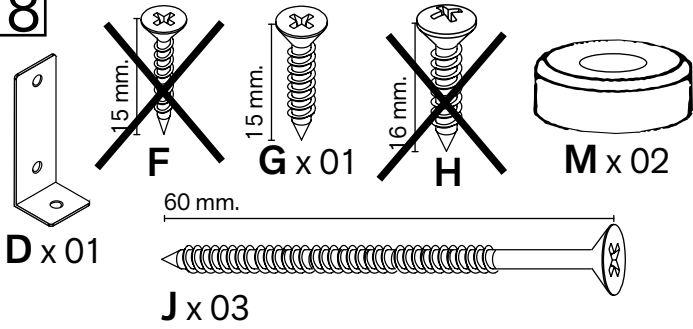

Option B

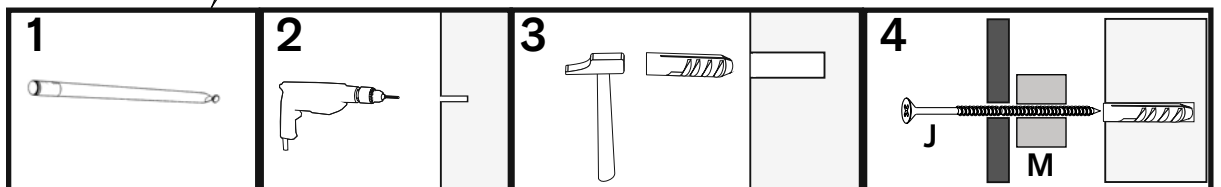
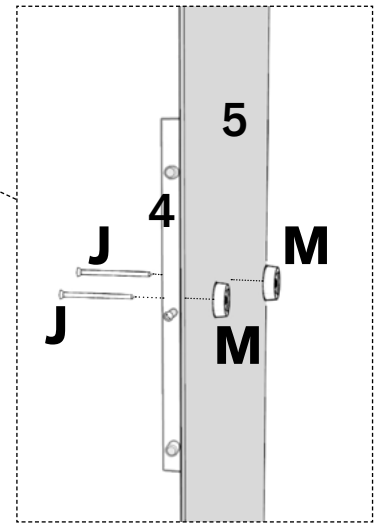
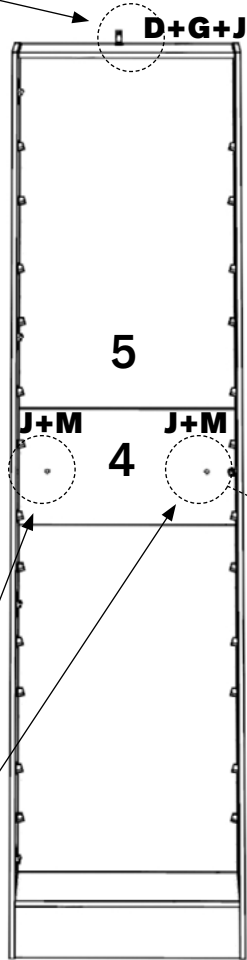
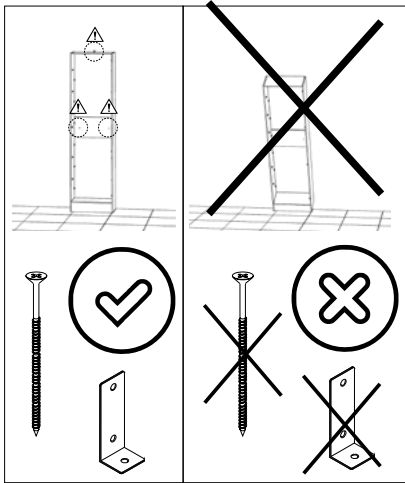
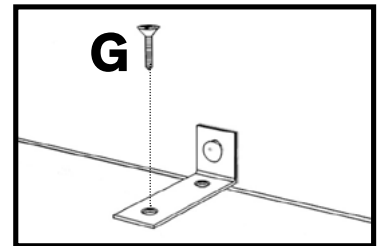
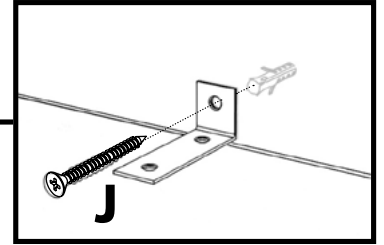
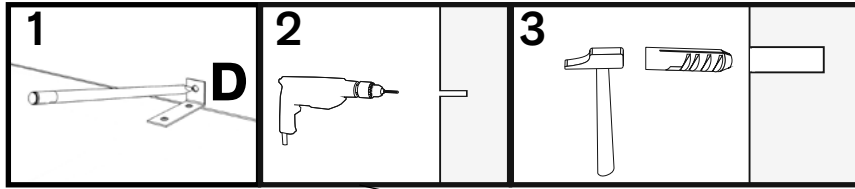

EN For your safety always fix the furniture to the wall. Use wall plugs and screws appropriate for your type of wall.

ES Por su seguridad fijar siempre el mueble a la pared. Use tacos y tornillos adecuados para su tipo de pared.

FR Pour votre sécurité, fixez toujours les meubles au mur. Utilisez des chevilles et des vis adaptées à votre type de mur.

PT Para sua segurança, prenda sempre os móveis à parede. Use buchas e parafusos adequados para o seu tipo de parede.

IT Per la tua sicurezza fissa sempre i mobili al muro. Utilizzare tasselli e viti appropriati per il tipo di muro.

DE Befestigen Sie die Möbel zu Ihrer Sicherheit immer an der Wand. Verwenden Sie für den Wandtyp geeignete Anker und Schrauben.

9

Option B

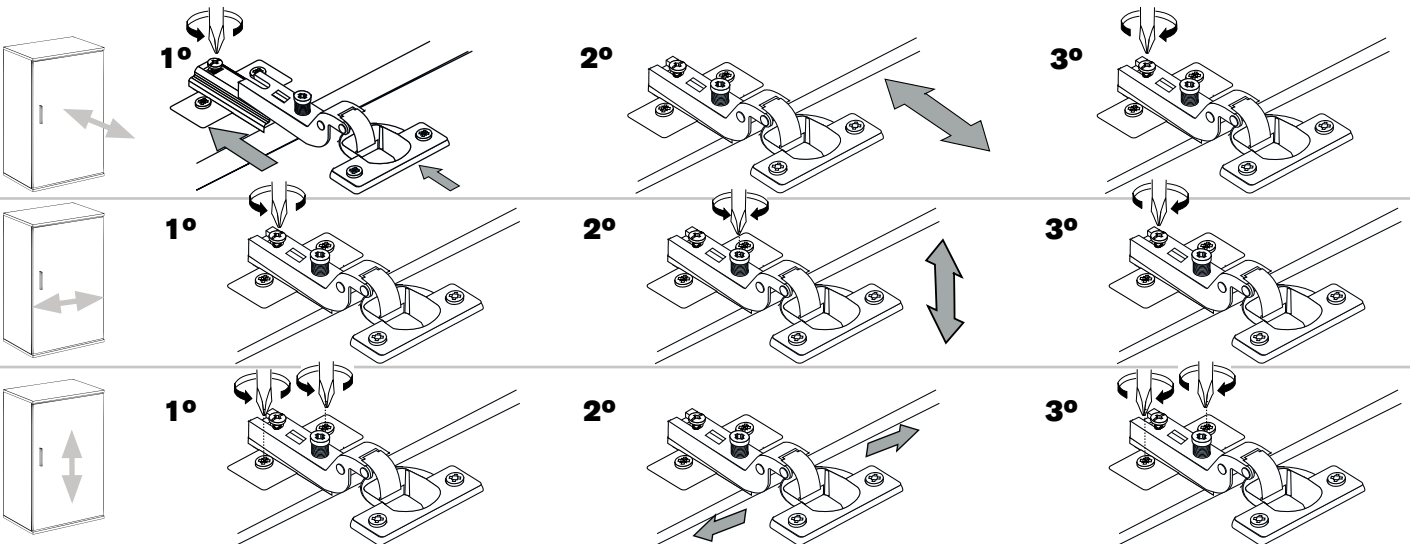
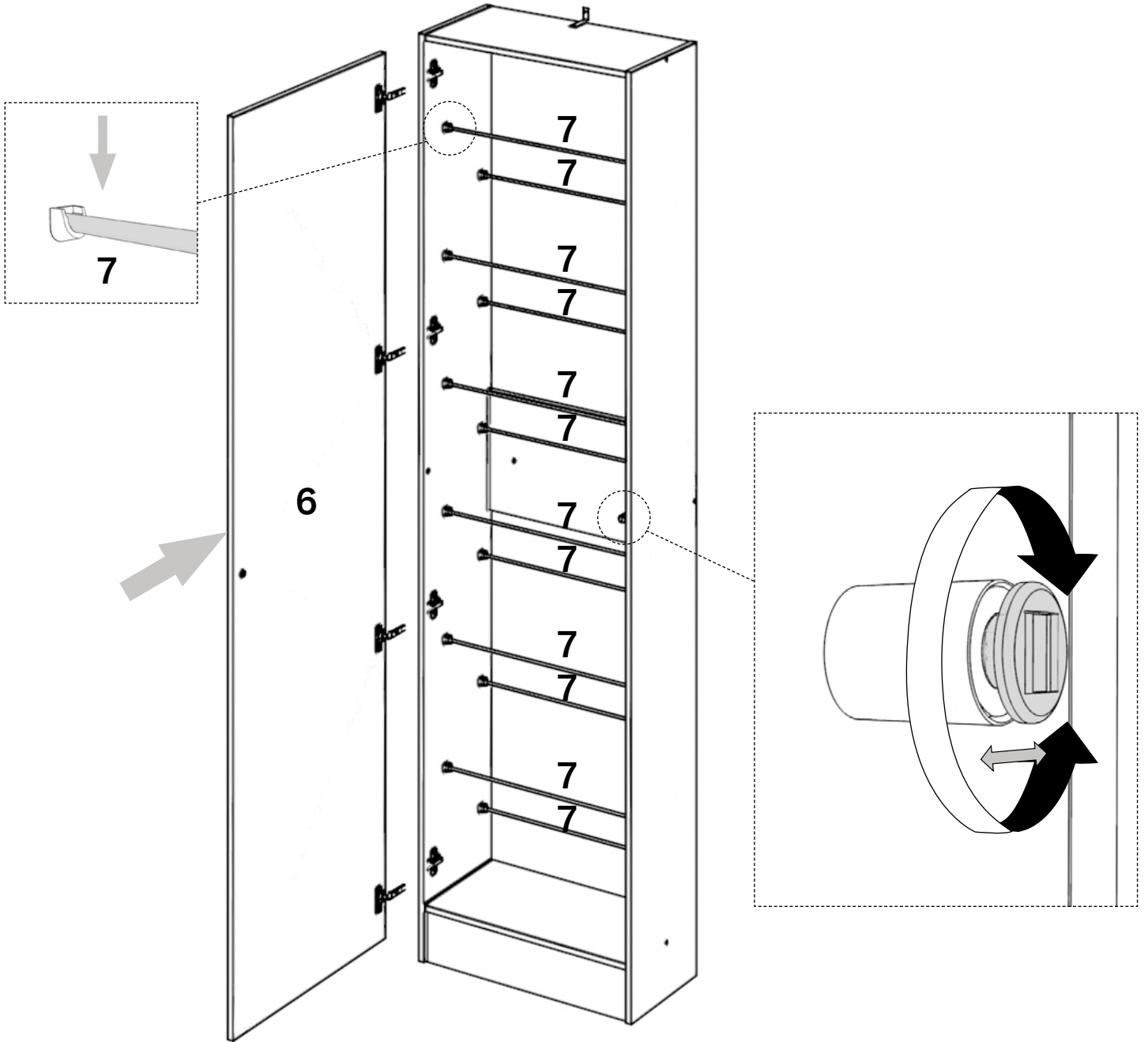

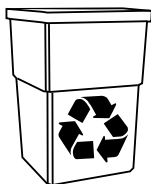

PLÁSTICO
PLASTIC
PLASTIQUE

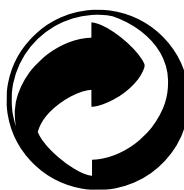

PEFC™
PEFC/14-35-00462
Promoting Sustainable
Forest Management
www.pefc.org

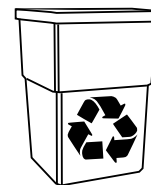
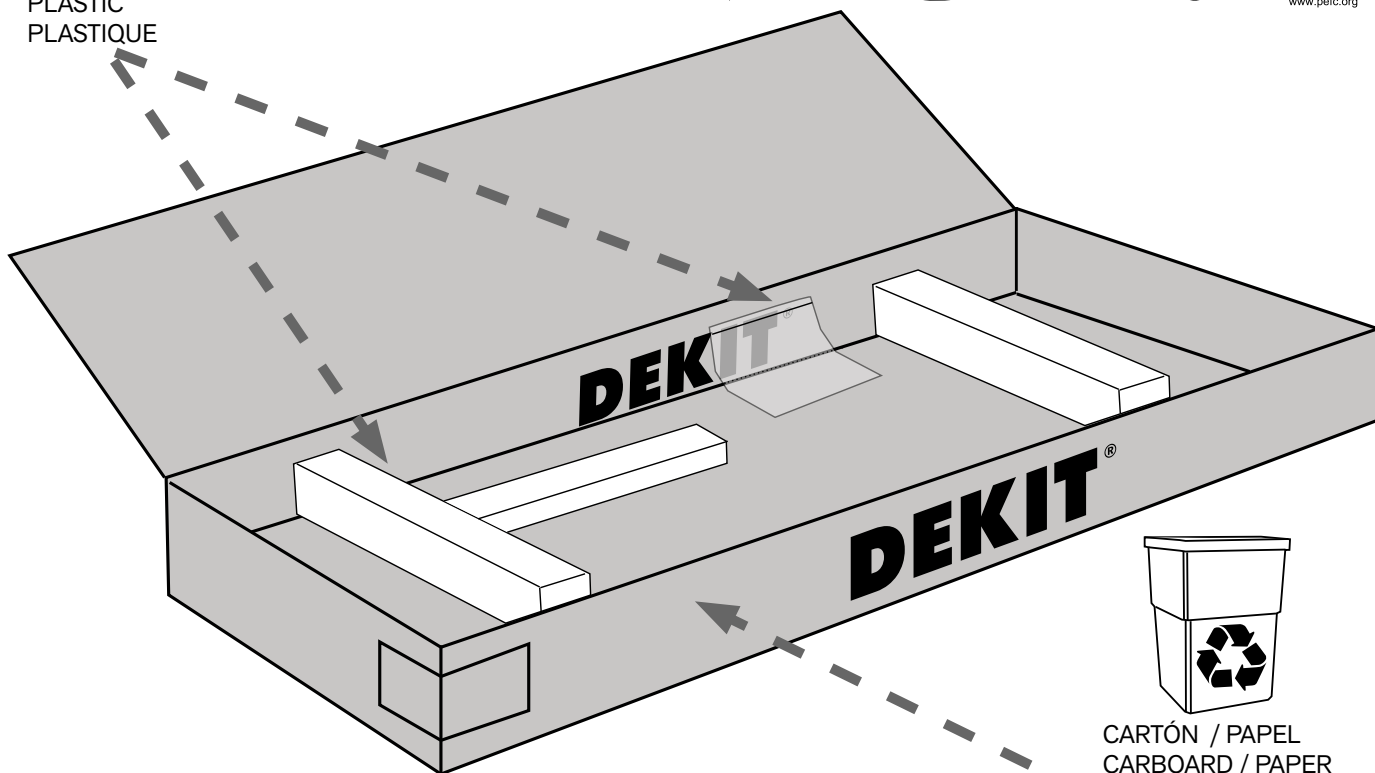

CARTÓN / PAPEL
CARBOARD / PAPER
CARTON / PAPIER

GARANTÍA - GUARANTEE - GARANTIE - GARANTIA - GARANZIA

ES

Fabricado en la U.E. por CIF A-12045134. Dirección: Ctra Vinaròs-Ulldecona, km 1 12500 Vinaròs Castellón ESPAÑA. Garantía de 3 años a partir fecha compra contra todo defecto de fabricación del producto. La garantía no incluye los defectos de mal montaje o mal uso del mueble. Para cualquier defecto en el mueble o dificultades durante el montaje, por favor contacte con el establecimiento o sitio web donde compró el mueble. Es necesario conservar el ticket de compra y el N° de Control de Calidad en caso de consulta o reclamación.

EN

Manufactured in the E.U. by CIF A-12045134, Address: Ctra Vinaròs-Ulldecona, km 1 12500 Vinaròs Castellón SPAIN. Guarantee of 3 years from the date of purchase against any manufacturing defect of the product. The guarantee does not include defects during the assembly or misuse of the furniture.

For any furniture defect of any difficulties during the assembly, please contact with the store or website where you purchased the furniture. It is necessary to keep the purchase ticket and the Quality Control N° in case of any question or claim.

FR

Fabriqué dans l'U.E. par CIF A-12045134, Adresse: Ctra Vinaròs-Ulldecona, km 1 12500 Vinaròs Castellón ESPAGNE. Garantie de 3 ans à compter de la date d'achat contre tout défaut de fabrication du produit. La garantie ne couvre pas les défauts dus à un mauvais montage ou à une mauvais utilisation du meuble.

Pour tout défaut du meuble ou difficultés lors du montage, veuillez contacter le magasin ou la web où vous avez acheté le meuble. Il est nécessaire de conserver la facture d'achat et le numéro de contrôle qualité en cas de demande d'information ou de laréclamation.

PT

Fabricado na U.E. por CIF A-12045134, Endereço: Ctra Vinaròs-Ulldecona, km 1 12500 Vinaròs Castellón ESPANHA. Garantia de 3 anos a partir da data de compra contra qualquer defeito de fabricação do produto. A garantia não inclui defeitos decorrentes de má montagem ou mau uso do móvel. Para qualquer defeito nos móveis ou dificuldades durante a montagem, entre em contato com a loja out site onde comprou os móveis.

É necessário guardar o talão de compra e indicar o N° do Controlo de Qualidade ao consultar ou reclamar.

IT

Prodotto nell'U.E. da CIF A-12045134, Indirizzo: Ctra Vinaròs-Ulldecona, km 1 12500 Vinaròs Castellón SPAGNA. 3 anni dalla data di acquisto contra qualsiasi difetto di fabbricazione del prodotto La garanzia non coprende i difetti dovuti al montaggio inadeguato o all'uso improprio dei mobili.

Per qualsiasi difetto del mobile o difficoltà durante il montaggio, si prega di contattare il negozio o il sito Web in cui è stato acquistato il mobile.

È necesario conservare il biglietto di acquisto e fornire il N° di Controllo Qualità in fase di consultaciones o reclamo.

N° Control Calidad: _____
Quality Control N°: _____
N° Contrôle Qualité: _____
N° Controlo Qualidade: _____
N° Controllo Qualità: _____